



**647776 EN (28/02/2020)**

MT 733 EASY 75D ST5 S1  
MT 933 EASY 75D ST5 S1  
MT 1033 EASY 75D ST5 S1

**OPERATOR'S MANUAL**  
*(ORIGINAL INSTRUCTIONS)*



**IMPORTANT**

*Carefully read and understand this instruction manual before using the lift truck.*

*It contains all information relating to operation, handling and lift truck equipment, as well as important recommendations to be followed.*

*This document also contains precautions for use, as well as information on the servicing and routine maintenance required to ensure the lift truck's continued safety of use and reliability.*

**WHenever you see this symbol it means:**



**WARNING ! BE CAREFUL ! YOUR SAFETY OR THE SAFETY OF THE LIFT TRUCK IS AT RISK.**

- This manual has been produced on the basis of the equipment list and the technical characteristics given at the time of its design.
- The level of equipment of the lift truck depends on the options chosen and the country of sale.
- According to the lift truck options and the date of sale, certain items of equipment/functions described herein may not be available.
- Descriptions and figures are non binding.
- MANITOU reserves the right to change its models and their equipment without being required to update this manual.
- The MANITOU network, consisting exclusively of qualified professionals, is at your disposal to answer all your questions.
- This manual is an integral part of the lift truck.
- It is to be kept in its storage space at all times for ease of reference.
- Hand this manual to the new owner if the lift truck is resold.



1st ISSUE	29/05/2019	
UPDATED	28/02/2020	2-15 ; 2-17 ; 2-19 ; 2-23 ; 2-25 ; 2-27 ; 2-50 ; 2-51 ; 2-64 – 2-68 3-38 4-5

Manitou BF S.A Limited liability company with a Board of Directors.  
 Head office: 430, Rue de l'Aubinière - 44150 Ancenis - FRANCE  
 Share capital: 39,548,949 euros  
 857 802 508 RCS Nantes.  
 Tel: +33 (0)2 40 09 10 11  
 www.manitou.com

*This manual is for information purposes only. Any reproduction, copy, representation, recording, transfer, distribution, or other, in part or in whole, in any format is prohibited. The plans, designs, views, commentaries and instructions, even the document organization that are found in this document, are the intellectual property of MANITOU BF. Any violation of the aforementioned may lead to civil and criminal prosecution. The logos as well as the visual identity of the company are the property of MANITOU BF and may not be used without express and formal authorization. All rights are reserved.*

**1 - OPERATING AND SAFETY INSTRUCTIONS**

**2 - DESCRIPTION**

**3 - MAINTENANCE**

**4 - OPTIONAL ADAPTABLE ATTACHMENTS FOR THE RANGE**





# ***1 - OPERATING AND SAFETY INSTRUCTIONS***





RED  
04  
MANITOU

## ASSISTANCE | 23 SIMPLE TIPS

The Manitou Group wishes to assist you in reducing the consumption of the machines to help you reduce your carbon footprint.



Choose a machine with an appropriate power rating for your needs.



Switch off your engine after running at idle for more than 3 minutes.



Optimum engine efficiency is achieved at the maximum torque engine speed.



Preferably use a fan control and reversal system.



Favor "smart" electronically-managed transmissions.



Use the air-conditioning with windows and doors closed.



Preferably use LED headlights.



Adapt the type of tire to your environment.



Ensure that your tires are inflated to the correct pressure.



Check the parking brake adjustment.

### Preferably use manufacturer-recommended attachments



Check the general condition of your trailer.



Adapt your maximum towable load.



Use the attachments that are suitable for your machine.



Check the hydraulic adjustment of your attachments.



Observe the maintenance periods.



Regularly clean the radiator, the air filter, etc.



Lubricate regularly.



Preferably buy through a manufacturer-approved dealer.



Favor OEM parts.



Study the manufacturers' maintenance contracts.



You can follow eco-driving courses.



Demand to know the consumption and emissions of the machines.



Calculate your consumption and emissions at [reduce.manitou.com](http://reduce.manitou.com)



## 1 - OPERATING AND SAFETY INSTRUCTIONS

### INSTRUCTIONS TO THE COMPANY MANAGER

1-6

<b>THE SITE</b>	<b>1-6</b>
<b>THE OPERATOR</b>	<b>1-6</b>
<b>THE LIFT TRUCK</b>	<b>1-6</b>
A - SUITABILITY OF THE LIFT TRUCK FOR THE JOB . . . . .	1-6
B - ADAPTATION OF THE LIFT TRUCK TO STANDARD ENVIRONMENTAL CONDITIONS . . . . .	1-6
C - MODIFICATION OF THE LIFT TRUCK . . . . .	1-7
D - FRENCH ROAD TRAFFIC RULES . . . . .	1-7
E - LIFT TRUCK CAB PROTECTION . . . . .	1-7
<b>INSTRUCTIONS</b>	<b>1-8</b>
<b>MAINTENANCE</b>	<b>1-8</b>

### INSTRUCTIONS FOR THE OPERATOR

1-10

<b>FOREWORD</b>	<b>1-10</b>
<b>GENERAL INSTRUCTIONS</b>	<b>1-10</b>
A - OPERATOR'S MANUAL . . . . .	1-10
B - AUTHORISATION FOR USE IN FRANCE . . . . .	1-10
C - MAINTENANCE . . . . .	1-10
D - TYRES . . . . .	1-10
E - MODIFICATION OF THE LIFT TRUCK . . . . .	1-11
F - LIFTING PEOPLE . . . . .	1-11
<b>OPERATING INSTRUCTIONS UNLADEN AND LADEN</b>	<b>1-12</b>
A - BEFORE STARTING THE LIFT TRUCK . . . . .	1-12
B - AVAILABLE IN THE DRIVER'S CAB . . . . .	1-12
C - ENVIRONMENT . . . . .	1-12
D - VISIBILITY . . . . .	1-13
E - STARTING THE LIFT TRUCK . . . . .	1-14
F - DRIVING THE LIFT TRUCK . . . . .	1-14
G - STOPPING THE LIFT TRUCK . . . . .	1-15
H - DRIVING THE LIFT TRUCK ON THE PUBLIC HIGHWAY . . . . .	1-16
<b>INSTRUCTIONS FOR HANDLING A LOAD</b>	<b>1-18</b>
A - CHOICE OF ATTACHMENTS . . . . .	1-18
B - WEIGHT OF LOAD AND CENTRE OF GRAVITY . . . . .	1-18
C - LONGITUDINAL STABILITY LIMITER AND WARNING DEVICE . . . . .	1-18
D - TRANSVERSE ATTITUDE OF THE LIFT TRUCK . . . . .	1-19
E - PICKING UP A LOAD ON THE GROUND . . . . .	1-19
F - PICKING UP AND PUTTING DOWN A HIGH LOAD ON TYRES . . . . .	1-20
G - PICKING UP AND PUTTING DOWN A HIGH LOAD ON STABILISERS . . . . .	1-22
H - PICKING UP AND PUTTING DOWN A SUSPENDED LOAD . . . . .	1-24
I - TRAVELLING WITH A SUSPENDED LOAD . . . . .	1-24
<b>INSTRUCTIONS FOR USE AS A LOADER</b>	<b>1-25</b>
A - LOADING . . . . .	1-25
B - BACKFILLING . . . . .	1-25
<b>PLATFORM OPERATING INSTRUCTIONS</b>	<b>1-26</b>
A - AUTHORISATION FOR USE . . . . .	1-26
B - SUITABILITY OF THE PLATFORM FOR THE JOB . . . . .	1-26
C - PROVIDED ON THE PLATFORM . . . . .	1-26
D - USING THE PLATFORM . . . . .	1-26
E - ENVIRONMENT . . . . .	1-27
F - MAINTENANCE . . . . .	1-27
<b>INSTRUCTIONS FOR USING THE RADIO-CONTROL</b>	<b>1-28</b>
HOW TO USE THE RADIO-CONTROL . . . . .	1-28
PROTECTIVE DEVICES . . . . .	1-28



**LIFT TRUCK MAINTENANCE INSTRUCTIONS**

**1-30**

<b>GENERAL INSTRUCTIONS</b>	<b>1-30</b>
<b>PLACING THE BOOM SAFETY WEDGE</b>	<b>1-30</b>
FITTING THE WEDGE . . . . .	1-30
REMOVING THE WEDGE . . . . .	1-30
<b>MAINTENANCE</b>	<b>1-30</b>
MAINTENANCE LOGBOOK . . . . .	1-30
<b>LUBRICANT AND FUEL LEVELS</b>	<b>1-31</b>
<b>HYDRAULICS</b>	<b>1-31</b>
<b>ELECTRICITY</b>	<b>1-31</b>
<b>WELDING</b>	<b>1-31</b>
<b>WASHING THE LIFT TRUCK</b>	<b>1-31</b>
<b>TRANSPORTING THE LIFT TRUCK</b>	<b>1-31</b>

**IF THE LIFT TRUCK IS NOT TO BE USED FOR A LONG TIME**

**1-32**

<b>INTRODUCTION</b>	<b>1-32</b>
<b>PREPARING THE LIFT TRUCK</b>	<b>1-32</b>
<b>DEF (Diesel Exhaust Fluid) TANK</b>	<b>1-32</b>
<b>PROTECTING THE ENGINE</b>	<b>1-32</b>
<b>PROTECTING THE LIFT TRUCK</b>	<b>1-32</b>
<b>BRINGING THE LIFT TRUCK BACK INTO SERVICE</b>	<b>1-33</b>

**LIFT TRUCK DISPOSAL**

**1-34**

<b>RECYCLING OF MATERIALS</b>	<b>1-34</b>
METALS . . . . .	1-34
PLASTICS . . . . .	1-34
RUBBER . . . . .	1-34
GLASS . . . . .	1-34
<b>ENVIRONMENTAL PROTECTION</b>	<b>1-34</b>
WORN OR DAMAGED PARTS . . . . .	1-34
USED OIL . . . . .	1-34
USED BATTERIES. . . . .	1-34



## INSTRUCTIONS TO THE COMPANY MANAGER

### THE SITE

Proper management of lift truck's area of travel will reduce the risk of accidents:

- ground not unnecessarily uneven or obstructed,
- no excessive slopes,
- pedestrian traffic controlled, etc.

### THE OPERATOR

- Only qualified, authorised personnel can use the lift truck. This authorisation is given in writing by the competent manager in the establishment for the use of lift trucks and must be carried permanently by the operator.

#### ⚠ IMPORTANT ⚠

*Experience has shown that there are a number of inappropriate ways in which the lift truck might be used. Such foreseeable misuse, of which the main examples are listed below, are strictly forbidden.*

- *The foreseeable abnormal behaviour resulting from ordinary negligence, but which does not result from any wish to put the machinery to any improper use.*
  - *The reflex reactions of a person in the event of a malfunction, incident, fault, etc. during operation of the lift truck.*
  - *Behaviour resulting from application of the "principle of least effort" when performing a task.*
  - *For certain machines, the foreseeable behaviour of such persons as: apprentices, teenagers, handicapped persons, trainees tempted to drive a lift truck, operators tempted to operate a truck for the purposes of a bet, a competition or for their own personal experience.*
- The person in charge of the equipment must take these criteria into account when assessing the suitability of a person to drive.*

### THE LIFT TRUCK

#### A - SUITABILITY OF THE LIFT TRUCK FOR THE JOB

- MANITOU has ensured that this lift truck is suitable for use under the standard operating conditions defined in this operator's manual, with a **STATIC TEST COEFFICIENT 1.25** and a **DYNAMIC TEST COEFFICIENT OF 1**, as specified in harmonised standard **EN 1459** for mast trucks.
- Before commissioning, the company manager must make sure that the lift truck is appropriate for the work to be done, and perform certain tests (in accordance with current legislation).

#### B - ADAPTATION OF THE LIFT TRUCK TO STANDARD ENVIRONMENTAL CONDITIONS

- Our lift trucks are designed to be used within a temperature range of -18 °C to +43 °C.
- In addition to standard equipment mounted on your lift truck, many options are available, such as: road lighting, brake lights, rotating beacon light, reversing lights, reversing sound alarm, front working light, rear working light, boom head working light, etc. (according to the lift truck model).
- The operator must take into account the operating conditions to specify the lift truck's signalling and lighting equipment. Contact your dealer.
- Take into account the weather and atmospheric conditions of the site in use.
  - Protection against frost (<math>\leq 3</math> - MAINTENANCE: LUBRICANTS AND FUEL).
  - Adaptation of lubricants (ask your dealer for information).
  - Engine filtration (<math>\leq 3</math> - MAINTENANCE: FILTER CARTRIDGES AND BELTS).

#### ⚠ IMPORTANT ⚠

*For use in average weather conditions, i.e. between -15°C and +35°C, the lubricants are topped up in the factory.*

*For operation under more severe climatic conditions, before starting up, it is necessary to drain all the circuits, then ensure correct levels of lubricants using lubricants properly suited to the relevant ambient temperatures.*

*The same applies to the cooling liquid.*

- Preventing fire risks associated with use in dusty and flammable conditions (e.g. straw, flour, sawdust, organic waste, etc.).
- A lift truck operating in an area without fire extinguishing equipment must be equipped with an individual extinguisher. There are solutions, consult your dealer.

#### ⚠ IMPORTANT ⚠

*Your lift truck is designed for outdoor use under normal atmospheric conditions and indoor use in suitably aerated and ventilated premises.*

*It is prohibited to use the lift truck in areas where there is a risk of fire or which are potentially explosive (e.g. Refineries, fuel or gas depots, stores of flammable products, etc.).*

*For use in these areas, specific equipment is available (ask your dealer for information).*

- Our lift trucks comply with Directive 2004/108/EC concerning electromagnetic compatibility (EMC), and with the corresponding harmonised standard EN 12895. Their correct operation is no longer guaranteed if they are used within areas in which the electromagnetic fields exceed the limit specified by this standard (10 V/m).



- Directive 2002/44/EC requires company managers to not expose their employees to excessive vibration doses. There is no recognised code of measurement for comparing the machines of different manufacturers. The actual doses received cannot therefore be measured under actual operating conditions at the user's premises.
- The following are some tips for minimizing these vibration doses:
  - Select the most suitable lift truck and attachment for the intended use.
  - Adapt the seat adjustment to the operator's weight (**according to lift truck model**) and maintain it in good condition, as well as the cab suspensions. Inflate the tyres in accordance with recommendations.
  - The seat is an essential way of reducing the vibrations transmitted to the operator. In the event of seat replacement, please contact MANITOU.
  - Ensure that the operators adapt their operating speed to suit the conditions on site.
  - As far as possible, arrange the site in such a way as to provide a flat running surface and remove obstacles and harmful potholes.

### C - MODIFICATION OF THE LIFT TRUCK

- For your safety and that of others, you must not change the structure and settings of the various components used in your lift truck (hydraulic pressure, calibrating limiters, engine speed, addition of extra equipment, addition of counterweight, unapproved attachments, alarm systems, etc.) yourself. In this event, the manufacturer cannot be held responsible.

### D - FRENCH ROAD TRAFFIC RULES

(or see current legislation in other countries)

- Only one EC declaration of conformity is issued. It must be kept in a safe place.
- The road traffic rules of lift trucks are subject to the provisions of the highway code, according to the following categories:
  - Construction-type trucks (MT range): public works vehicle not predominantly for use on roads (point 6.9 of Article R311-1 of the French Highway Code). The truck must have a 25 disc displayed on the rear of the vehicle and an operating licence plate.
  - Agricultural-type trucks (MLT range) that are non-EC type approved tractors: (point 6.2 of Article R311/1 of the French Highway Code). The truck must be fitted with an operating licence plate.
  - Agricultural-type trucks (MLT range) that are EC type approved tractors: agricultural tractor type T1a (point 5.1.1 of Article R311/1 of the French Highway Code). The truck must be registered.

### SPECIAL INSTRUCTION APPLYING TO "EC TRACTOR" TYPE-APPROVED LIFT TRUCKS

- All EC tractor type-approved lift trucks are supplied with an "EC tractor" certificate complying with directive 2003/37/EC, to be retained by the owner, and a page of administrative details together with a CNIT number (national type approval code) for registration at the prefecture.
- The lift truck owner is responsible for carrying out the necessary procedures for obtaining the vehicle registration document within the time limit defined by the regulations.
- The operator must hold a category B driver's licence, unless granted an exemption.
- The lift truck must be driven on the public highway in accordance with the instructions given in the manual supplied with the lift truck (Gross weight, Gross combination weight, towing load, axle loads, maximum speeds, etc. according to type/version). The operator must be in possession of the lift truck's registration document.

**⚠ IMPORTANT ⚠**

*When towing a trailer or agricultural equipment, the travelling speed of the lift truck is limited to 25 km/h.  
In this case, a "25" disc must be affixed to the rear of the convoy.*

### E - LIFT TRUCK CAB PROTECTION

- All lift trucks comply with the requirements of ISO 3471 (wheel loader code) regarding cab rollover protection (ROPS) and ISO 3449 (Level II) regarding the protection of the cab against falling objects (FOPS).
- "EC TRACTOR" type-approved lift trucks comply, in addition, with Directive 79/622/EC (OECD Code 4) regarding cab rollover protection (ROPS).

**⚠ IMPORTANT ⚠**

*Structural damage or overturning, a modification, changes or a poorly executed repair can reduce the protective efficiency of the cab, cancelling its compliance.  
Do not perform welding or drilling on the cab structure.  
Consult your dealer to determine the limits of this structure without cancelling its compliance.*



## INSTRUCTIONS

- The operator's manual must always be in good condition and kept in the place provided on the lift truck and in the language used by the operator.
- The operator's manual and any plates or stickers which are no longer legible or are damaged, must be replaced immediately.

## MAINTENANCE

- Maintenance or repairs other than those detailed in Part: 3 - MAINTENANCE must be carried out by qualified personnel (consult your dealer) and in the necessary safety conditions to preserve the health of the operator and any third party.

**⚠ IMPORTANT ⚠**

*Your lift truck must be inspected periodically to ensure that it remains in compliance.*

*The frequency of this inspection is defined by current legislation in the country in which the lift truck is used.*

- Example for France "The manager in charge of the establishment using a lift truck must open and maintain a maintenance log for each machine (order of 2 March 2004) and undergo a general periodic inspection every 6 months (order of 1 March 2004)".





## INSTRUCTIONS FOR THE OPERATOR

### FOREWORD

#### ⚠ IMPORTANT ⚠

*The risk of accident while using, servicing or repairing your lift truck can be restricted if you follow the safety instructions and safety measures detailed in these instruction. Failure to respect the safety and operating instructions, or the instructions for repairing or servicing your lift truck may lead to serious, even fatal accident.*

- Only the operations and manoeuvres described in these operator's manual must be performed. The manufacturer cannot predict all possible risky situations. Consequently, the safety instructions given in the operator's manual and on the lift truck itself are not exhaustive.
- At any time, as an operator, you must envisage, within reason, the possible risk to yourself, to others or to the lift truck itself when you use it.

#### ⚠ IMPORTANT ⚠

*In order to reduce or prevent any danger with a MANITOU-approved attachment, follow the instructions in Paragraph: 4 - ADAPTABLE ATTACHMENTS AS OPTIONS ON THE RANGE: INTRODUCTION.*

### GENERAL INSTRUCTIONS

#### A - OPERATOR'S MANUAL

- Read the operator's manual carefully.
- The operator's manual must always be in good condition and in the place provided for it on the lift truck.
- You must report any plates and stickers which are no longer legible or which are damaged.

#### B - AUTHORISATION FOR USE IN FRANCE

*(or see current legislation in other countries).*

- Only qualified, authorized personnel can use the lift truck. This authorization is given in writing by the appropriate person in the establishment with respect to the use of lift trucks and must be carried permanently by the operator.
- The operator is not competent to authorise the driving of the lift truck by another person.

#### C - MAINTENANCE

- The operator must immediately advise his superior if his lift truck is not in good working order or does not comply with the safety notice.
- The operator is prohibited from carrying out any repairs or adjustments himself, unless he has been trained for this purpose. He must keep the lift truck properly cleaned if this is among his responsibilities.
- The operator is responsible for carrying out daily maintenance (↩ 3 - MAINTENANCE).
- The operator is responsible for deciding and adjusting the frequency of cleaning needed to prevent the risk of fire ensuing from the build-up of flammable material(s). The operator should pay special attention to all the areas of the lift truck where these risk materials are likely to accumulate.

#### D - TYRES

- The operator must ensure tyres are adapted to the nature of the ground (see area of the contact surface of the tyres in the chapter: 2 - DESCRIPTION: TYRES). There are optional solutions, consult your dealer.
  - SAND tyres.
  - FARM tyres.
  - Snow chains.
- The lift truck's four tyres must be the same brand and the same usage category (normal, snow or special), have the same structure (radial or diagonal) and have the same degree of tread wear.
- In the event of tyre replacement, use tyres authorised by MANITOU that are the same type and dimensions. Using different tyres voids the lift truck's type approval and you may be liable.
- If you are replacing just one of the lift truck's tyres (e.g. because it is damaged), we recommend choosing a tyre with the same degree of wear as the remaining tyres so as not the damage the transmission's kinematic chain.

#### ⚠ IMPORTANT ⚠

*Do not use the lift truck if the tyres are incorrectly inflated, damaged or excessively worn, because this could put your own safety or that of others at risk, or cause damage to the lift truck itself.*

*The fitting of foam inflated tyres is prohibited and is not guaranteed by the manufacturer, excepting prior authorisation.*



**E - MODIFICATION OF THE LIFT TRUCK**

- For your safety and that of others, you must not change the structure and settings of the various components used in your lift truck (hydraulic pressure, calibrating limiters, engine speed, addition of extra equipment, addition of counterweight, unapproved attachments, alarm systems, etc.) yourself. In this event, the manufacturer cannot be held responsible.

**F - LIFTING PEOPLE**

- The use of working equipment and load lifting attachments to lift people is:
  - either forbidden
  - or authorised exceptionally and under certain conditions (↔ regulations in force in the country in which the lift truck is used).
- The pictogram posted at the operator station reminds you that:
  - Left-hand column
    - It is forbidden to lift people, with any kind of attachment, using a non PLATFORM-fitted lift truck.
  - Right-hand column
    - With a PLATFORM-fitted lift truck, people can only be lifted using platforms designed by MANITOU for the purpose.
- MANITOU sells equipment specifically designed for lifting people (OPTION PLATFORM lift truck, contact your dealer).

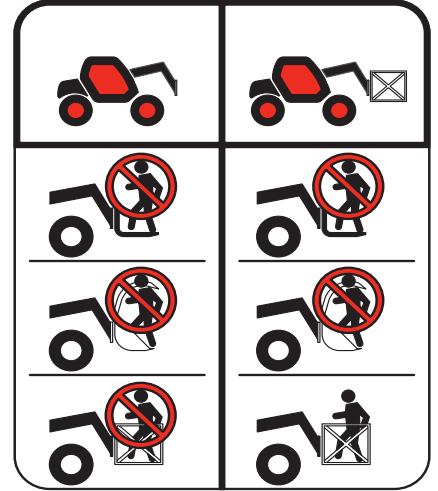



## OPERATING INSTRUCTIONS UNLADEN AND LADEN

### A - BEFORE STARTING THE LIFT TRUCK

- Perform the daily maintenance operations (↩ 3 - MAINTENANCE).
- Make sure that the driver's cab is clean, particularly the floor and floor mat. Check that no movable object may hinder the operation of the lift truck.
- Make sure the lights, indicators and windscreen wipers are working properly.
- Make sure the rear view mirrors are in good condition, clean and properly adjusted.
- Make sure the horn works.

### B - AVAILABLE IN THE DRIVER'S CAB

- Whatever his experience, the operator is advised to familiarize himself with the position and operation of all the controls and instruments before operating the lift truck.
- Wear clothes suited for driving the lift truck, avoid loose clothes.
- Make sure you have the appropriate protective equipment for the task to be performed.
- Prolonged exposure to high noise levels may cause hearing problems. It is recommended to wear ear muffs to protect against excessive noise.
- Always face the driver's cab access when getting in and out of the lift truck and use the handle(s) provided for this purpose. Do not jump out of the lift truck to get down.
- Always pay attention when using the lift truck. Do not listen to the radio or music using headphones or earphones.
- Never operate the lift truck when hands or feet are wet or soiled with greasy substances.
- For increased comfort, adjust the seat to your requirements and adopt the correct position in the driver's cab.

**⚠ IMPORTANT ⚠**

*Under no circumstances must the seat be adjusted while the lift truck is moving.*

- The operator must always be in his normal position in the driver's cab. It is prohibited to have arms or legs, or generally any part of the body, protruding from the driver's cab of the lift truck.
- The safety belt must be worn and adjusted to the operator's size.
- The control units must never in any event be used for any other than their intended purposes (e.g. climbing onto or down from the lift truck, portmanteau, etc.).
- If the control components are fitted with a forced operation (lever lock) device, it is forbidden to leave the cab without first putting these controls in neutral.
- It is prohibited to carry passengers either on the lift truck or in the driver's cab.

### C - ENVIRONMENT

- Comply with site safety regulations.
- If you have to use the lift truck in a dark area or at night, make sure it is equipped with working lights.
- During handling operations, make sure that no one is in the way of the lift truck and its load.
- Do not allow anybody to come near the working area of the lift truck or pass beneath an elevated load.
- When using the lift truck on a transverse slope, before lifting the boom observe the instructions given in the paragraph: INSTRUCTIONS FOR HANDLING A LOAD: D - TRANSVERSE ATTITUDE OF THE LIFT TRUCK.
- Travelling on a longitudinal slope:
  - Drive and brake gently.

- Moving without load: forks or attachment facing downhill.

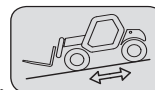

- Moving with load: Forks or attachment facing uphill.

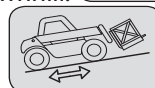



- Take into account the lift truck's dimensions and its load before trying to negotiate a narrow or low passageway.
- Never move onto a loading platform without having first checked:
  - That it is suitably positioned and made fast.
  - That the unit to which it is connected (wagon, lorry, etc.) will not shift.
  - That this platform is prescribed for the total weight of the lift truck to be loaded.
  - That this platform is prescribed for the size of the lift truck.
- Never move onto a foot bridge, floor or freight lift, without being certain that they are prescribed for the weight and size of the lift truck to be loaded and without having checked that they are in sound working order.
- Be careful in the area of loading bays, trenches, scaffolding, soft ground and manholes.
- Make sure the ground is stable and firm under the wheels and/or stabilizers before lifting or removing the load. If necessary, add sufficient wedging under the stabilizers.
- Make sure that the scaffolding, loading platform, pilings or ground is capable of bearing the load.
- Never stack loads on uneven ground, they may tip over.

**⚠ IMPORTANT ⚠**

*If the load or the attachment must remain above a structure for a prolonged period of time, there is the risk that it will bear on the structure as the boom descends due to cooling of the oil in the cylinders.*

*To eliminate this risk:*

- *Regularly check the distance between the load or the attachment and the structure and readjust this if necessary.*
- *If possible use the lift truck at an oil temperature as close as possible to ambient temperature.*

- When working near aerial lines, ensure that the safety distance is sufficient between the working area of the lift truck and the aerial line.

**⚠ IMPORTANT ⚠**

*You must consult your local electrical agency.*

*You could be electrocuted or seriously injured if you operate or park the lift truck too close to power cables.*

*In the event of high winds, do not carry out handling work that jeopardises the stability of the lift truck and its load, particularly if the load catches the wind badly.*

- Prevent fire risks associated with use in dusty and flammable conditions (e.g. straw, flour, sawdust, organic waste, etc.).

**D - VISIBILITY**

- The safety of people within the lift truck's working area, as well as that of the lift truck itself and the operator are depend on good operator visibility of the lift truck's immediate vicinity in all situations and at all times.
- This lift truck has been designed to allow good operator visibility (direct or indirect by means of rear-view mirrors) of the immediate vicinity of the lift truck during running operations, unladen and boom in the transport position.
- Special precautions must be taken if the size of the load restricts visibility towards the front:
  - moving in reverse,
  - site layout,
  - assisted by a person directing the manoeuvre (while standing outside the truck's area of travel), making sure to keep this person clearly in view at all times,
  - in any case, avoid reversing over long distances.
- Certain special accessories may require the truck to travel with the boom in the raised position. In such cases, visibility on the right hand side is restricted, and special precautions must be taken:
  - site layout,
  - assisted by a person directing the manoeuvre (while standing outside the truck's area of travel).
  - replacement of a suspended load by a load on a pallet.
- If visibility of your road is inadequate, ask someone to assist by directing the manoeuvre (while standing outside the truck's area of travel), making sure to keep this person clearly in view at all times.
- Keep all components affecting visibility in a clean, properly adjusted state and in good working order (e.g. windscreens, windows, windscreen wipers, windscreen washers, driving and work lights, rear-view mirrors).



## E - STARTING THE LIFT TRUCK

### SAFETY INSTRUCTIONS

**⚠ IMPORTANT ⚠**

*The lift truck must only be started up or manoeuvred when the operator is sitting in the driver's cab, with his seat belt adjusted and fastened.*

- Never try to start the lift truck by pushing or hauling it. Such an operation may cause severe damage to the transmission. If necessary, towing requires the transmission to be put in neutral (↩ 3 - MAINTENANCE).
- If using an emergency battery for start-up, use a battery with the same characteristics and respect battery polarity when connecting it. Connect at first the positive terminals before the negative terminals.

**⚠ IMPORTANT ⚠**

*Failure to respect polarity between batteries can cause serious damage to the electrical circuit.*

*The electrolyte in the battery may produce an explosive gas. Avoid flames and generation of sparks close to the batteries.*

*Never disconnect a battery while it is charging.*

### INSTRUCTIONS

- Check the closing and locking of the hood(s).
- Check that the cab door is closed.
- Check that the forward/reverse selector is in neutral, and that the parking brake is engaged.
- Firmly press the brake pedal and hold in position and hold it down.
- Turn the ignition key to the position I to activate the electrical and preheat system.
- Whenever you switch on the lift truck, perform the automatic check on the longitudinal stability limiter and warning device (↩ 2 - DESCRIPTION: INSTRUMENTS AND CONTROLS). Do not use the lift truck that is non-compliant.
- Check the fuel level on the indicator.
- Turn the ignition key fully, the engine should then start. Release the ignition key and let the engine run at idle.
- Do not engage the starter motor for more than 15 seconds and carry out the preheating between unsuccessful attempts.
- Make sure all the signal lights on the control instrument panel are off.
- Check all control instruments when the engine is warm and at regular intervals during use, so as to quickly detect any faults and to be able to correct them without any delay.
- If an instrument does not show the correct display, stop the engine and immediately carry out the necessary operations.

## F - DRIVING THE LIFT TRUCK

### SAFETY INSTRUCTIONS

**⚠ IMPORTANT ⚠**

*The operators' attention is drawn to the risks involved in using the lift truck, in particular:*

*- Risk of losing control.*

*- Risk of losing lateral and frontal stability of the lift truck.*

*The operator must remain in control of the lift truck.*

*In the event of the lift truck overturning, do not try to leave the cabin during the incident.*

**YOUR BEST PROTECTION IS TO STAY FASTENED IN THE CABIN.**

- Observe the company's traffic regulations or, by default, the public highway code.
- Do not carry out operations which exceed the capacities of your lift truck or attachments.
- Always drive the lift truck with the forks or attachment to the transport position, i.e. at 300 mm from the ground, the boom retracted and the carriage sloping backwards.
- Only carry loads which are balanced and properly anchored to avoid any risk of a load falling off.
- Ensure that pallets, cases, etc. are in good order and suitable for the load to be lifted.
- Familiarise yourself with the lift truck on the terrain where it will be used.
- Ensure that the service brakes are working properly.
- The loaded lift truck must not travel at speeds in excess of 12 km/h.
- Drive smoothly at an appropriate speed for the operating conditions (land configuration, load on the lift truck).
- Do not use the hydraulic boom controls when the lift truck is moving.
- Never change the steering mode whilst driving.
- Do not manoeuvre the lift truck with the boom in the raised position unless under exceptional circumstances and then with extreme caution, at very low speed and using gentle braking. Ensure that visibility is adequate.
- Take bends slowly.
- In all circumstances make sure you are in control of your speed.
- On damp, slippery or uneven terrain, drive slowly.
- Brake gently, never abruptly.
- Only use the lift truck's forward/reverse selector from a stationary position and never do so abruptly.
- Do not drive with your foot on the brake pedal.
- Always remember that hydrostatic type steering is extremely sensitive to movement of the steering wheel, so turn it gently and not jerkily.
- Never leave the engine on when the lift truck is unattended.
- Do not leave the cab when the lift truck has a raised load.
- Look where you are going and always make sure you have good visibility along the route.



- Use the rear-view mirrors frequently.
- Drive round obstacles.
- Never drive on the edge of a ditch or steep slope.
- It is dangerous to use two lift trucks simultaneously to handle heavy or bulky loads, since this operation requires particular precautions to be taken. It must only be used exceptionally and after risk analysis.
- The ignition switch has an emergency stop mechanism in case of an operating anomaly occurring in the case of lift trucks not fitted with a punch-operated cut-out.

#### INSTRUCTIONS

- Always drive the lift truck with the forks or attachment to the transport position, i.e. at 300 mm from the ground, the boom retracted and the carriage sloping backwards.
- For lift trucks with gearboxes, use the recommended gear (⚠ 2 - DESCRIPTION: CONTROL AND COMMAND INSTRUMENTS).
- Select the steering mode appropriate for the use and/or working conditions (⚠ 2 - DESCRIPTION: COMMAND AND CONTROL INSTRUMENTS) (according to model of lift truck).
- Release the hand brake.
- Shift the forward/reverse selector to the selected direction of travel and accelerate gradually until the lift truck moves off.

#### **⚠ IMPORTANT ⚠**

*Starting and moving the lift truck on a slope may be a real hazard.*

*If the lift truck is parked or stopped, adhere scrupulously to the following instructions for moving it:*

- Press the service brake pedal.
- Engage 1st or 2nd gear (depending on the lift truck model)
- Select forward or reverse direction.
- Ensure that there is no one or anything impeding the movement of the lift truck.
- Release the service brake pedal and accelerate the engine.

*The use of the lift truck loaded or with a trailer increases the risk. In this case, remain extremely vigilant.*

#### **G - STOPPING THE LIFT TRUCK**

##### SAFETY INSTRUCTIONS

- Never leave the ignition key in the lift truck during the operator's absence.
- When the lift truck is stationary, or if the operator has to leave his cab (even for a moment), place the forks or attachment on the ground, apply the parking brake and place the forward/reverse selector in neutral.
- Make sure that the lift truck is not stopped in any position that will interfere with the traffic flow and at less than one meter from the track of a railway.
- In the event of prolonged parking on a site, protect the lift truck from bad weather, particularly from frost (check the level of antifreeze), close and lock all the lift truck accesses (doors, windows, cowls, etc.).

##### INSTRUCTIONS

- Park the lift truck on flat ground or on an incline lower than 15%.
- Set the forward/reverse selector to neutral.
- Apply the parking brake.
- For lift trucks with gearboxes, place the gear lever in neutral.
- Fully retract the boom.
- Lower the forks or attachment to rest on the ground.
- When using an attachment with a grab or jaws, or a bucket with hydraulic opening, close the attachment fully.
- Before stopping the lift truck after a long working period, leave the engine idling for a few moments, to allow the coolant liquid and oil to lower the temperature of the engine and transmission. Do not forget this precaution, in the event of frequent stops or warm stalling of the engine, or else the temperature of certain parts will rise significantly due to the stopping of the cooling system, with the risk of badly damaging such parts.
- Stop the engine with the ignition switch.
- Remove the ignition key.
- Lock all access to the lift truck (doors, windows, cowls, etc).



## H - DRIVING THE LIFT TRUCK ON THE PUBLIC HIGHWAY

(or see current legislation in other countries)

### FRENCH ROAD TRAFFIC RULES

- The driving of non EC type-approved tractors on the public highway is subject to the provisions of the highway code relating to special machines, defined in article R311-1 of the highway code, in category B of the Equipment Order of 20 November 1969 that determines the procedures applicable to special machines. The lift truck must be fitted with a licence plate.
- The driving of EC type-approved tractors on the public highway is subject to the provisions of the highway code regarding agricultural tractors, defined in article R311-1 of the highway code. The lift truck must be registered.
- The lift truck must be driven on the public highway in accordance with the instructions given in the manual supplied with the lift truck (Gross weight, Gross combination weight, towing load, axle loads, maximum speeds, etc. according to type/version). The operator must be in possession of the lift truck's registration document.
- The operator must hold an HGV licence, unless granted an exemption.
- When towing a trailer or agricultural equipment, the travelling speed of the lift truck is limited to 25 km/h. In this case, a "25" disc must be affixed to the rear of the convoy.

### SAFETY INSTRUCTIONS

- Operators driving on the public highway must comply with current highway code legislation.
- The lift truck must comply with current road legislation. If necessary, there are optional solutions. Contact your dealer.

### INSTRUCTIONS

- Make sure the revolving light is in place, switch it on and verify its operation.
- Make sure the lights, indicators and windscreen wipers are working properly.
- Switch off the working headlights if the lift truck is fitted with them.
- Select the steering mode "HIGHWAY TRAFFIC" (<img alt="arrow icon" data-bbox="114 384 128 398"/> 2 - DESCRIPTION: CONTROL AND COMMAND INSTRUMENTS) (according to model of lift truck).
- Fully retract the boom and set the attachment approximately 300 mm off the ground.
- Place the slope compensation in the central position, i.e. the transverse axis of the axles parallel to the frame (depending on the lift truck model).
- Fully raise the stabilisers and turn the shoes inwards (depending on the model of lift truck).

#### **⚠ IMPORTANT ⚠**

***Never coast in neutral (forward/reverse selector or gear lever in neutral or transmission cut-off button pressed) to preserve the lift truck engine brake. Failure to observe this instruction on a slope will lead to excessive speed which may make the lift truck uncontrollable (steering, brakes) and cause serious mechanical damage.***

### DRIVING THE LIFT TRUCK WITH A FRONT-MOUNTED ATTACHMENT

- You must comply with current regulations in your country, covering the possibility of driving on the public highway with a front-mounted attachment on your lift truck.
- If road legislation in your country authorizes circulation with a front-mounted attachment, you must at least:
  - Protect and report any sharp and/or dangerous edges on the attachment (<img alt="arrow icon" data-bbox="114 578 128 592"/> 4 - ADAPTABLE ATTACHMENTS AVAILABLE ON THE RANGE).
  - The attachment must not be loaded.
  - Make sure that the attachment does not mask the lighting range of the forward lights.
  - Make sure that current legislation in your country does not require other obligations.

### OPERATING THE LIFT TRUCK WITH A TRAILER

- For using a trailer, observe the regulations in force in your country (maximum travel speed, braking, maximum weight of trailer, etc.).
- Do not forget to connect the trailer's electrical equipment to that of the lift truck.
- The trailer's braking system must comply with current legislation.
- If pulling a trailer with assisted braking, the tractor lift truck must be equipped with a trailer braking mechanism. In this case, do not forget to connect the trailer braking equipment to the lift truck.
- The vertical force on the towing hook must not exceed the maximum authorised by the manufacturer (consult the manufacturer's plate on your lift truck).
- The authorised gross vehicle weight must not exceed the maximum weight authorised by the manufacturer (<img alt="arrow icon" data-bbox="114 784 128 798"/> 2 - DESCRIPTION: CHARACTERISTICS).

**IF NECESSARY, CONSULT YOUR DEALER.**



## INSTRUCTIONS FOR HANDLING A LOAD

### A - CHOICE OF ATTACHMENTS

- Only attachments approved by MANITOU can be used on its lift trucks.
- Make sure the attachment is suitable for the work to be done (↩ 4 - ADAPTABLE ATTACHMENTS AS OPTIONS ON THE RANGE).
- If the lift truck is equipped with the single side-shift carriage OPTION (TSDL), use only the authorised attachments (↩ 4 - ADAPTABLE ATTACHMENTS AS OPTIONS ON THE RANGE).
- Make sure the attachment is correctly installed and locked onto the lift truck carriage.
- Make sure that your lift truck attachments work properly.
- Comply with the load chart limits for the lift truck for the attachment used.
- Do not exceed the rated capacity of the attachment.
- Never lift a slung load without the attachment provided for the purpose, as there is a risk of the sling slipping (↩ INSTRUCTIONS FOR HANDLING A LOAD: H - PICKING UP AND PUTTING DOWN A SUSPENDED LOAD).
- Do not handle loads suspended by straps directly on the forks (e.g.:big bags), as there is a risk of shearing on sharp edges. Use an attachment designed for this purpose.

### B - WEIGHT OF LOAD AND CENTRE OF GRAVITY

- Before picking up a load, you must know its mass and its centre of gravity.
- The longitudinal position of the centre of gravity in relation to the heel of the forks (Fig. B1) is defined on the load chart concerning your lift truck (↩ 2 - DESCRIPTION: DIMENSIONS AND LOAD CHARTS). For a higher centre of gravity consult your dealer.
- For irregular loads, determine the transverse centre of gravity before any handling (fig. B2) and place it in the longitudinal axis of the lift truck.

**⚠ IMPORTANT ⚠**

*It is forbidden to move a load heavier than the effective capacity defined on the lift truck load chart.  
For loads with a moving centre of gravity (e.g. liquids), take account of the variations in the centre of gravity in order to determine the load to be handled and be extra vigilant and careful to limit these variations as far as possible.*

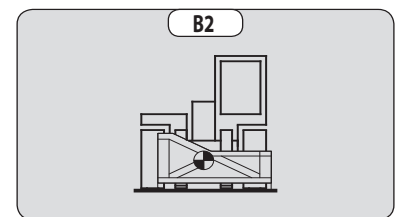
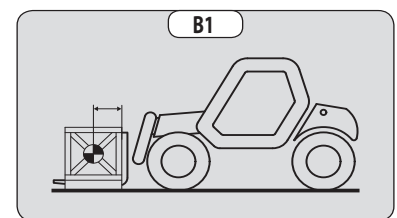

### C - LONGITUDINAL STABILITY LIMITER AND WARNING DEVICE

This device gives an indication of the longitudinal stability of the lift truck, and limits hydraulic movements in order to ensure this stability, at least under the following operating conditions:

- when the lift truck is at a standstill,
- when the lift truck is on firm, stable and consolidated ground,
- when the lift truck is performing handling and placing operations.
- Move the boom very carefully when approaching the authorised load limit (↩ 2 - DESCRIPTION: COMMAND AND CONTROL INSTRUMENTS).
- Always watch this device during handling operations.
- If the "AGGRAVATING" hydraulic movements are cut off, perform only de-aggravating hydraulic movements in the following order (fig. C): if necessary, raise the boom (1), retract the boom as far as possible (2) and lower the boom (3) to put down the load.

**⚠ IMPORTANT ⚠**

*The instrument reading may be erroneous when the steering is at full lock or the rear axle is oscillated to its maximum extent.  
Before lifting a load, make sure that the lift truck is not in either of these situations.*

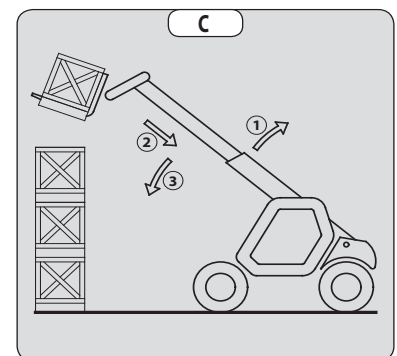

## D - TRANSVERSE ATTITUDE OF THE LIFT TRUCK

Depending on the model of lift truck

The transverse attitude is the transverse slope of the chassis with respect to the horizontal. Raising the boom reduces the lift truck's lateral stability. The transverse attitude must be set with the boom in down position as follows:

### 1 - LIFT TRUCK WITHOUT LEVELLING USED ON TYRES

- Position the lift truck so that the spirit level bubble is between the two lines (↔ 2 - DESCRIPTION: COMMAND AND CONTROL INSTRUMENTS).

### 2 - LIFT TRUCK WITH LEVELLING USED ON TYRES

- Correct the tilt using the hydraulic control and check the horizontality with the spirit level. The bubble in the level must be between the two lines (↔ 2 - DESCRIPTION: COMMAND AND CONTROL INSTRUMENTS).

### 3 - LIFT TRUCK USED ON STABILISERS

- Put the two stabilisers on the ground and raise the two front wheels of the lift truck (fig. D1).
- Correct the tilt using the stabilisers (fig. D2) and check the horizontality with the spirit level. The bubble of the level must be between the two lines (↔ 2 - DESCRIPTION: COMMAND AND CONTROL INSTRUMENTS). In this position, the two front wheels must be off the ground.

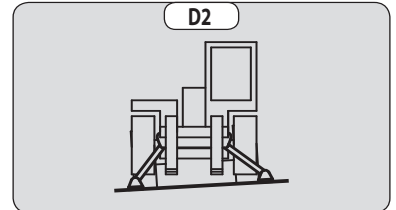
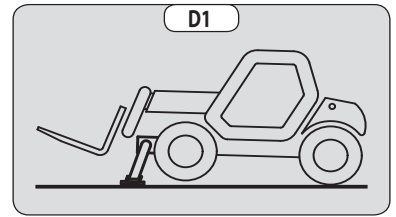

## E - PICKING UP A LOAD ON THE GROUND

- Approach the lift truck perpendicular to the load, with the boom retracted and the forks horizontal (fig. E1).
- Adjust the fork spacing and centring relative to the load to ensure stability (fig. E2) (optional solutions exist, consult your dealer).
- Never lift a load with a single fork.

**⚠ IMPORTANT ⚠**

*Beware of the risks of trapping or squashing limbs when manually adjusting the forks.*

- Move the lift truck forward slowly (1) and bring the forks up to the stop in front of the load (fig. E3). If necessary, slightly lift the boom (2) while picking up the load.
- Bring the load into the transport position.
- Tilt the load far enough backwards to ensure stability (loss of load on braking or going downhill).

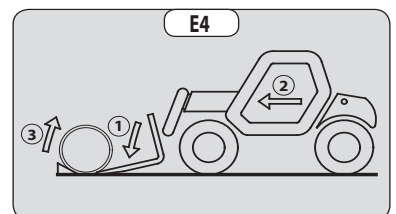
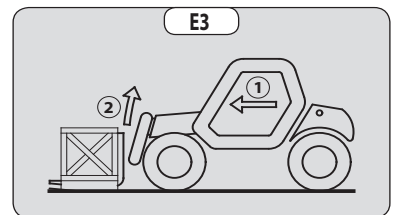
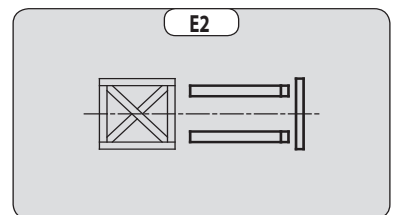
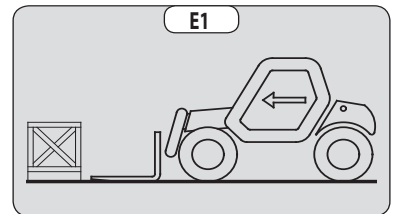

### FOR A NON-PALLETISED LOAD

- Tilt the carriage (1) forwards and move the lift truck slowly forwards (2), to insert the fork under the load (fig. E4) (chock the load if necessary).
- Continue to move the lift truck forwards (2) tilting the carriage (3) (fig. E4) backwards to place the load on the forks and ensure the load's longitudinal and lateral stability.

## F - PICKING UP AND PUTTING DOWN A HIGH LOAD ON TYRES

### ⚠ IMPORTANT ⚠

*In no circumstances should you raise the boom if you have not checked the transverse attitude of the lift truck*  
 (⚠ INSTRUCTIONS FOR HANDLING A LOAD: D - TRANSVERSE ATTITUDE OF THE LIFT TRUCK).

REMINDER: Make sure that the following operations can be performed with good visibility (⚠ OPERATING INSTRUCTIONS UNLADEN AND LADEN: D - VISIBILITY).

### PICKING UP A HIGH LOAD ON TYRES

- Ensure that the forks will easily pass under the load.
- Raise and extend the boom (1) (2) until the forks are level with the load, moving the lift truck (3) forward if necessary (fig. F1), moving very slowly and carefully.
- Always remember to keep the distance necessary for inserting the forks under the load, between the stack and the lift truck (fig. F1) and use the shortest possible boom length.
- Bring the forks to the stop in front of the load by alternately extending and lowering the boom (1) or, if necessary, moving the lift truck forward (2) (fig. F2). Apply the parking brake and place the forward/reverse selector in neutral.
- Slightly raise the load (1) and tilt the carriage (2) backwards to stabilise the load (fig. F3).
- Tilt the load sufficiently backwards to ensure its stability.
- Monitor the longitudinal stability limiter and warning device (⚠ INSTRUCTIONS FOR HANDLING A LOAD: C - LONGITUDINAL STABILITY LIMITER AND WARNING DEVICE). If it is overloaded, put the load back down in the place from which it was picked up.
- If possible lower the load without moving the lift truck. Raise the boom (1) to release the load, retract (2) and lower the boom (3) to put the load into transport position (fig. F4).
- If this is not possible, reverse the lift truck (1), manoeuvring very gently and carefully to release the load. Retract (2) and lower the boom (3) to bring the load into the transport position (fig. F5).

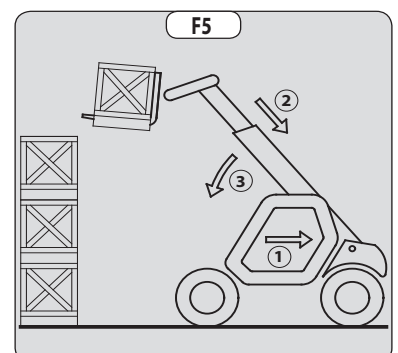
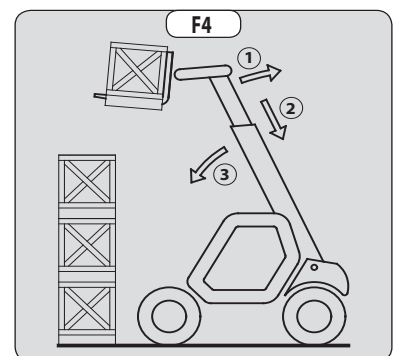
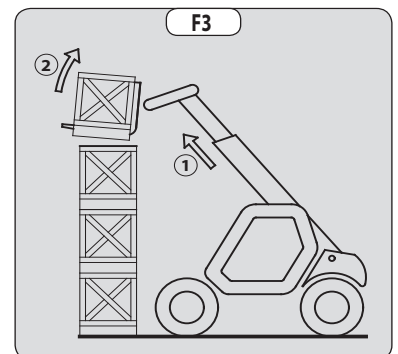
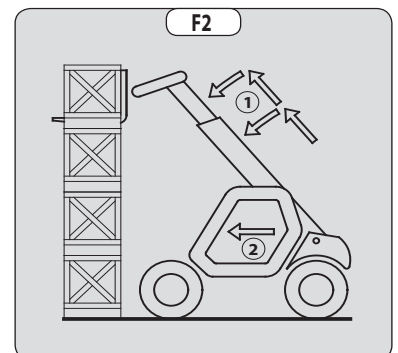
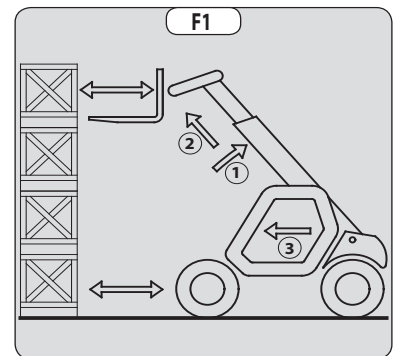

**PUTTING DOWN A HIGH LOAD ON TYRES**

- Approach the load in the transport position in front of the stack (fig. F6).
- Apply the parking brake and place the forward/reverse selector in neutral.
- Raise and extend the boom (1) (2) until the load is above the stack, while monitoring the longitudinal stability limiter and warning device (← INSTRUCTIONS FOR HANDLING A LOAD: C - LONGITUDINAL STABILITY LIMITER AND WARNING DEVICE). If necessary, move the lift truck (3) forward (fig. F7), driving very slowly and carefully.
- Place the load in a horizontal position and put it down on the pile by lowering and retracting the boom (1) (2) in order to position the load correctly (fig. F8).
- If possible, release the forks by alternately retracting and raising the boom (1) (fig. F9). Then put the forks into transport position.
- If this is not possible, reverse the lift truck (1), manoeuvring very slowly and carefully to release the forks (fig. F10). Then put them into transport position.

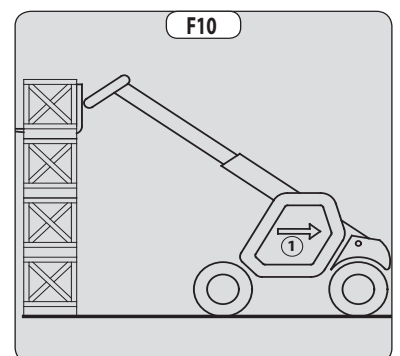
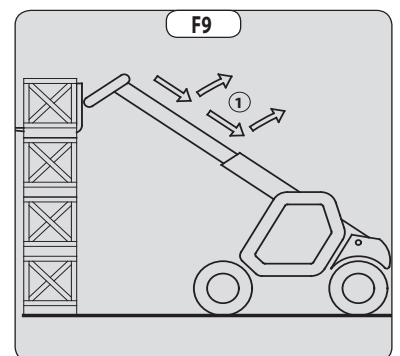
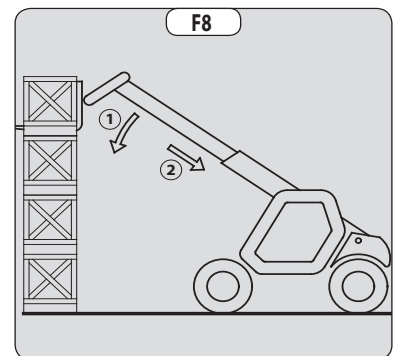
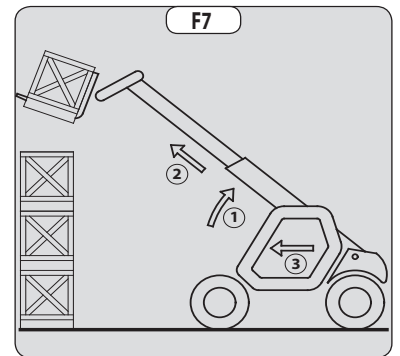
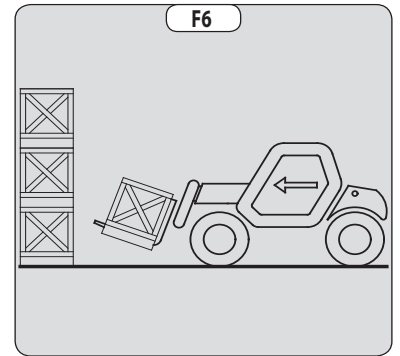



**G - PICKING UP AND PUTTING DOWN A HIGH LOAD ON STABILISERS**

Depending on the model of lift truck

**⚠ IMPORTANT ⚠**

*In no circumstances should you raise the boom if you have not checked the transverse attitude of the lift truck (← INSTRUCTIONS FOR HANDLING A LOAD: D - TRANSVERSE ATTITUDE OF THE LIFT TRUCK).*

REMINDER: Make sure that the following operations can be performed with good visibility (← OPERATING INSTRUCTIONS UNLADEN AND LADEN: D - VISIBILITY).

The stabilisers are used to optimise the lift truck's lifting performance (← 2 - DESCRIPTION: COMMAND AND CONTROL INSTRUMENTS).

**POSITIONING THE STABILISERS WITH THE FORKS IN TRANSPORT POSITION (UNLADEN AND LADEN)**

- Set the forks in transport position in front of the elevation.
- Stay far enough away to allow the boom to be raised.
- Apply the parking brake and place the forward/reverse selector in neutral.
- Put the two stabilisers on the ground and lift the two front wheels of the lift truck (fig. G1), making sure the lift truck has transverse attitude.

**RAISING THE STABILISERS WITH THE FORKS IN TRANSPORT POSITION (UNLADEN AND LADEN)**

- Raise both stabilizers fully and at the same time.

**LOWERING THE STABILISERS WITH BOOM UP (UNLADEN AND LADEN)**

**⚠ IMPORTANT ⚠**

*This operation must be exceptional and performed with great care.*

- Raise the boom and retract the telescopes completely.
- Bring the lift truck into position in front of the elevation (fig. G2) moving very slowly and carefully.
- Apply the parking brake and place the forward/reverse selector in neutral.
- Move the stabilizers very slowly and gradually as soon as they are close to the ground or in contact with it.
- Lower the two stabilisers and lift the two front wheels of the lift truck (fig. G3). During this operation, transverse attitude must be permanently maintained: the bubble in the level must be kept between the two lines.

**SETTING THE STABILISERS WITH THE BOOM UP (UNLADEN AND LADEN)**

**⚠ IMPORTANT ⚠**

*This operation must be exceptional and performed with great care.*

- Keep the boom raised and retract the telescopes completely (fig. G3).
- Move the stabilisers very slowly and gradually as soon as they are in contact with the ground and when they leave the ground. During this operation, the transverse attitude must be permanently maintained: the bubble in the level must be kept between the two lines.
- Raise both stabilizers completely.
- Release the parking brake and reverse the lift truck (1) very slowly and carefully, to release it and lower the forks (2) into transport position (fig. G4).

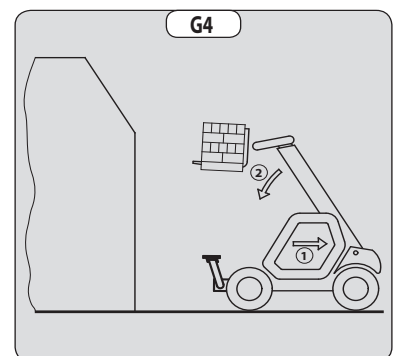
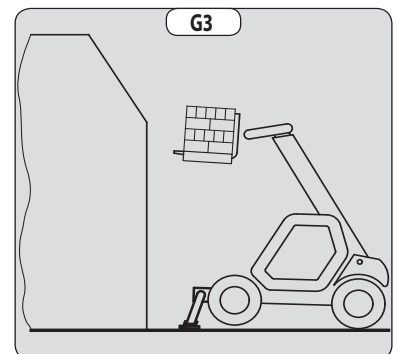
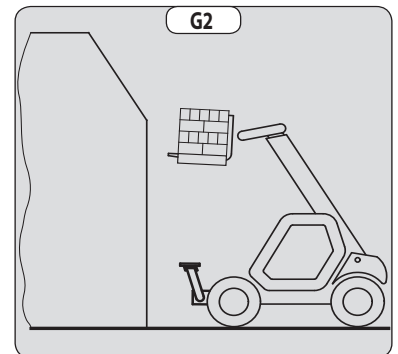
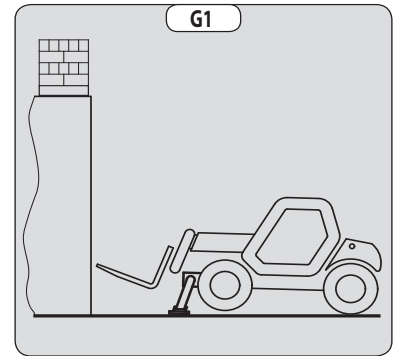

### TAKING UP A HIGH LOAD ON STABILISERS

- Ensure that the forks will easily pass under the load.
- Check the position of the lift truck with respect to the load and make a test run, if necessary, without taking the load.
- Raise and extend the boom (1) (2) until the forks are at the level of the load (fig. G5).
- Bring the forks to the stop in front of the load by alternately extending and lowering the boom (1) (fig. G6).
- Lift the load slightly (1) and tilt the carriage (2) backwards to stabilise the load (fig. G7).
- Monitor the longitudinal stability limiter and warning device (← INSTRUCTIONS FOR HANDLING A LOAD: C - LONGITUDINAL STABILITY LIMITER AND WARNING DEVICE).
- If it is overloaded, put the load back down in the place from which it was picked up. Raise the boom (1) to release the load, retract (2) and lower the boom (3) to put the load into transport position (fig. F4).

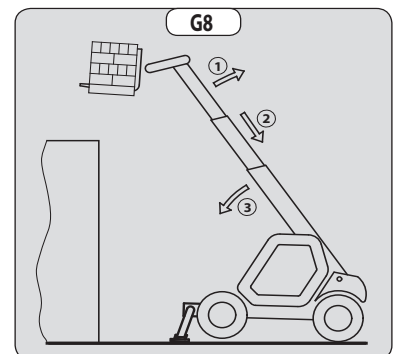
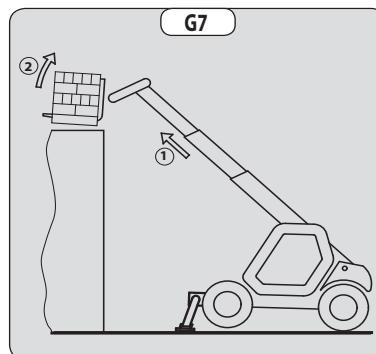
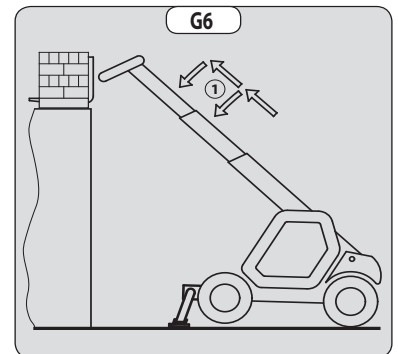
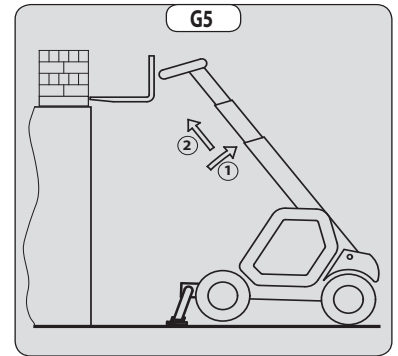

### SETTING DOWN A HIGH LOAD ON STABILISERS

- Raise and extend the boom (1) (2) until the load is above the elevation (fig. G9), while monitoring the longitudinal stability limiter and warning device (← INSTRUCTIONS FOR HANDLING A LOAD: C - LONGITUDINAL STABILITY LIMITER AND WARNING DEVICE).
- Position the load horizontally and release it by lowering and retracting the boom (1) (2) to position the load correctly (fig. G10).
- Free the forks by alternately retracting and raising the boom (3) (fig. G11).
- If possible, put the boom in transport position without moving the lift truck.

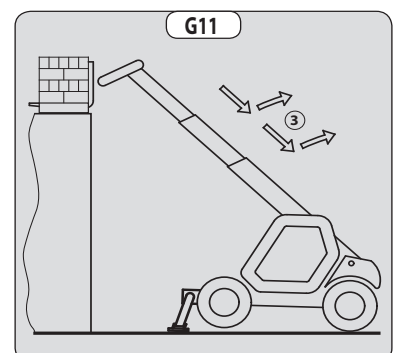
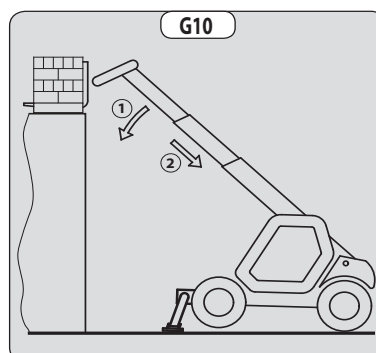
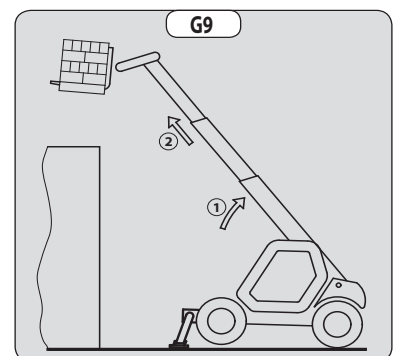



## H - PICKING UP AND PUTTING DOWN A SUSPENDED LOAD

### **⚠ IMPORTANT ⚠**

*Failure to follow the above instructions may lead the lift truck to loose stability and overturn.  
MUST be used with a lift truck equipped with an operational hydraulic movement cut-out device.*

#### CONDITIONS OF USE

- The length of the sling or the chain shall be as short as possible to limit swinging of the load.
- Lift the load vertically along its axis, never by pulling sideways or lengthways.

#### HANDLING WITHOUT MOVING THE LIFT TRUCK

- Whether on stabilisers or on tyres, the lateral attitude must not exceed 1% and the longitudinal attitude must not exceed 5%, the bubble of the level must be kept at "0".
- Ensure that the wind speed is not higher than 10 m/s.
- Ensure that there is no one between the load and the lift truck.

#### I - TRAVELLING WITH A SUSPENDED LOAD

- Before moving, inspect the terrain in order to avoid excessive slopes and cross-falls, bumps and potholes, or soft ground.
- Ensure that the wind speed is not higher than 36 km/h.
- The lift truck must not travel at more than 0.4 m/s (1.5 km/h, i.e. one quarter walking speed).
- Drive and stop the lift truck gently and smoothly to minimise swinging of the load.
- Carry the load a few centimetres above the ground (max. 30 cm) the shortest possible boom length. Do not exceed the offset indicated on the load chart. If the load begins to swing excessively, do not hesitate to stop and lower the boom to set down the load.
- Before moving the lift truck, check the longitudinal stability limiter and warning device (⚠ 2 - DESCRIPTION: COMMAND AND CONTROL INSTRUMENTS), only the green LEDs and possibly the yellow LEDs should be lit.
- During transport, the lift truck operator must be assisted by a person on the ground (standing a minimum of 3 m from the load), who will limit swinging of the load using a bar or a rope. Ensure that this person is always clearly in view.
- The lateral attitude must not exceed 5%, the bubble in the level must be kept between the two "MAX" marks.
- The longitudinal attitude must not exceed 15% with the load facing uphill, and 10% with the load facing downhill.
- The boom angle must not exceed 45°.
- If the first red LED of the longitudinal stability limiter and warning device (⚠ 2 - DESCRIPTION: COMMAND AND CONTROL INSTRUMENTS) comes on while travelling, gently stop the lift truck and stabilise the load. Retract the telescope to reduce the offset of the load.



## INSTRUCTIONS FOR USE AS A LOADER

For agricultural-type lift trucks (MLT range)

### A - LOADING

**⚠ IMPORTANT ⚠**

*In no circumstances should you raise the boom if you have not checked the transverse attitude of the lift truck (← INSTRUCTIONS FOR HANDLING A LOAD: D - TRANSVERSE ATTITUDE OF THE LIFT TRUCK).*

REMINDER: Make sure that the following operations can be performed with good visibility (← OPERATING INSTRUCTIONS UNLADEN AND LADEN: D - VISIBILITY).

#### FILLING THE BUCKET

- Place the bottom of the bucket in a horizontal position, just in contact with the ground (1) (fig. A1).
- Move forward gradually (2) while simultaneously raising the boom and tilting the bucket backwards (3), for improved filling and breakout (fig. A1).
- Reverse the lift truck (1) very carefully and gently to free the bucket. Lower the boom (2) into the transport position (fig. A2).

**⚠ IMPORTANT ⚠**

*Tilt the bucket sufficiently back to avoid spilling product and ensure its stability (loss of product under braking).*

#### LOADING A TRAILER

- Approach the side of the trailer in the transport position (fig. A3).
- Raise and extend the boom (1) (2) until the bucket is above the trailer, while monitoring the longitudinal stability limiter and warning device (← INSTRUCTIONS FOR HANDLING A LOAD: C - LONGITUDINAL STABILITY LIMITER AND WARNING DEVICE) (fig. A4).
- Drive the lift truck forward (3) very carefully and gently so that the bucket empties its load in the centre of the trailer (fig. A4).
- Apply the parking brake on and set the reversing lever to neutral.
- Slowly discharge the product (4) (fig. A4).
- Tilt the bucket backwards (1) and reverse the lift truck (2) very carefully and gently (fig. A5).
- Retract (3) and lower the boom (4) into the transport position (fig. A5).

### B - BACKFILLING

- Place the bottom of the bucket in a horizontal position, just in contact with the ground (1) (fig. B1).
- Drive forward gradually (2). Once filled, the bucket will act as a levelling blade (fig. B1).

**⚠ IMPORTANT ⚠**

*When driving, beware of trenches as well as recently excavated and/or backfilled ground.*

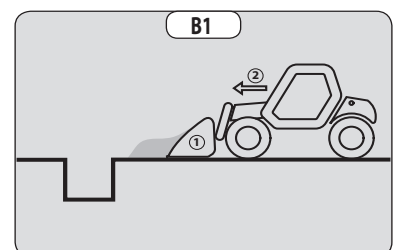
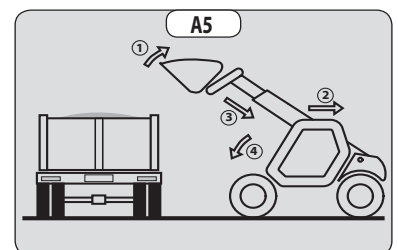
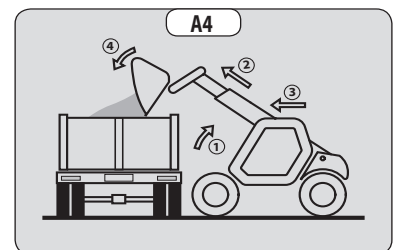
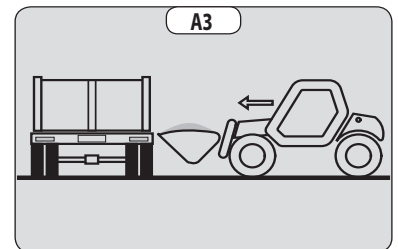
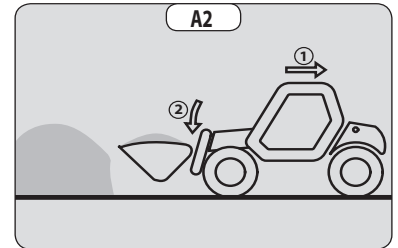
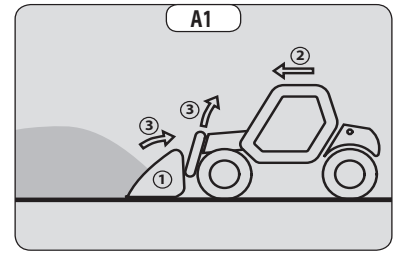



## PLATFORM OPERATING INSTRUCTIONS

For lift trucks fitted with a PLATFORM

### A - AUTHORISATION FOR USE

- Operation of the platform requires further authorisation in addition to that of the lift truck.

### B - SUITABILITY OF THE PLATFORM FOR THE JOB

- Our lift trucks fitted with "mobile elevating work platforms" are compliant with the standard **EN 280:2013+A1** for Europe and the standard **AS/NZS 1418.10:2011** for Australia, corresponding to the classification of Group C1 to C3 complying with this standard.
- MANITOU has ensured that this platform is suitable for use under the normal operating conditions provided in this operator's manual, with a **STATIC test coefficient of 1.25** and a **DYNAMIC test coefficient of 1.1** as specified in harmonised European standard **EN 280:2013+A1** for "mobile elevating work platforms".
- Before commissioning, the company manager must make sure that platform is appropriate for the work to be done, and perform certain tests (in accordance with current legislation).

### C - PROVIDED ON THE PLATFORM

- Wear suitable clothing when using the platform, avoid loosely-fitting garments.
- Never operate the platform when hands or feet are wet or soiled with greasy substances.
- Remain alert at all times when using the platform. Do not listen to the radio or music using headphones or earphones.
- For increased comfort, adopt the correct position at the platform's operator station.
- The platform's guard rail exempts the operator from wearing a safety harness under normal operating conditions. As a result, you are responsible for deciding whether to wear a safety harness.

NOTE: Make sure that current legislation in your country does not include the obligation to wear a harness.

- The control units must never in any event be used for any other than their intended purposes (e.g. climbing onto or down from the lift truck, portmanteau, etc.).
- Safety helmets must be worn.
- The operator must always be in the normal operator's position. It is prohibited to have arms or legs, or generally any part of the body, protruding from the basket.
- Ensure that any materials loaded onto the platform (pipes, cables, containers, etc.) cannot fall out. Do not pile these materials to the point where it is necessary to step over them.

### D - USING THE PLATFORM

- However experienced they may be, operators must acquaint themselves with the emplacement and operation of all control instruments prior to operating the platform.
- Check before use that the platform has been correctly assembled and locked onto the lift truck.
- Check before operating the platform that the access gate has been properly locked.
- The platform should be operated in an area free of any obstructions or danger when it is lowered to the ground.
- The operator using the platform must be aided on the ground by a person with adequate training.
- You should stay within the limits set out in the platform load chart.
- The lateral constraints are limited ( $\leq 2$  - DESCRIPTION: CHARACTERISTICS).
- It is strictly forbidden to suspend a load from the platform or the lift truck boom without an attachment provided for this ( $\leq$  INSTRUCTIONS FOR HANDLING A LOAD: H - PICKING UP AND PUTTING DOWN A SUSPENDED LOAD).
- The platform cannot be used as a crane or a lift for permanently transporting people or materials, nor as jacks or supports.
- The lift truck must not be moved with one (or more) person(s) in the platform.
- It is forbidden to transport people on the platform using the hydraulic controls in the lift truck's driver's cab (except in case of rescue).
- The operator must not climb onto to off the platform when it is not on ground level (boom retracted and in the down position).
- The platform must not be fitted with attachments that increase the unit's wind load.
- Do not use ladders or improvised structures in the platform to gain extra height.
- Do not climb onto the sides of the platform to gain extra height.
- It is forbidden to use the platform on forks. The fork slots are only to be used for storing the platform and not for lifting people under any circumstances.



**E - ENVIRONMENT**

**⚠ IMPORTANT ⚠**

*It is forbidden to use the platform close to electricity cables. Maintain the specified safe distances.*

RATED VOLTAGE	SAFETY DISTANCE (METRES)
50 < U < 1,000	2,30 M
1,000 < U < 30,000	2,50 M
30000 < U < 45000	2,60 M
45000 < U < 63000	2,80 M
63000 < U < 90000	3,00 M
90000 < U < 150000	3,40 M
150000 < U < 225000	4,00 M
225000 < U < 400000	5,30 M
400000 < U < 750000	7,90 M

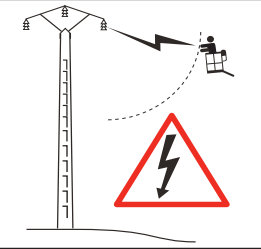

**⚠ IMPORTANT ⚠**

*It is strictly forbidden to use the platform when the wind speed exceeds 45 km/h.*

- To visually recognise this wind speed, refer to the empirical wind evaluation scale below:

BEAUFORT scale (wind speed at a height of 10 m on a flat site)						
Force	Type of wind	Speed (knots)	Speed (km/h)	Speed (m/s)	Effects on Land	Sea conditions
0	Calm	0 - 1	0 - 1	<0.3	Smoke rises vertically.	Sea is like a mirror.
1	Light air	1 - 3	1 - 5	0.3 - 1.5	Smoke indicates direction of wind.	Ripples with appearance of scale, no foam crests.
2	Light breeze	4 - 6	6 - 11	1.6 - 3.3	Wind felt on face, leaves rustle.	Short wavelets, but pronounced.
3	Gentle breeze	7 - 10	12 - 19	3.4 - 5.4	Leaves and small twigs in constant motion.	Very small waves, crests begin to break.
4	Moderate breeze	11 - 16	20 - 28	5.5 - 7.9	Wind raises dust and loose pieces of paper; small branches are moved.	Small waves, becoming longer, numerous whitecaps.
5	Fresh breeze	17 - 21	29 - 38	8 - 10.7	Small trees in leaf begin to sway.	Wavelets form on inland waters; moderate waves, taking longer form.
6	Strong breeze	22 - 27	39 - 49	10.8 - 13.8	Large branches in motion, whistling heard in overhead wires, umbrella use becomes difficult.	Larger waves forming, whitecaps everywhere, some spray.
7	Near gale	28 - 33	50 - 61	13.9 - 17.1	Whole trees in motion, inconvenience felt when walking against the wind.	Sea heaps up; white foam from breaking waves begins to be blown in streaks along the direction of the wind.
8	Gale	34 - 40	62 - 74	17.2 - 20.7	Wind breaks twigs off trees; impedes progress.	Moderately high waves of greater length; edges of crests begin to break into spindrift.
9	Strong gale	41 - 47	75 - 88	20.8 - 24.4	Wind damages roofs (chimneys, slates, etc.).	High waves, crests of waves begin to topple, streaks of foam; reduced visibility.
10	Storm	48 - 55	89 - 102	24.5 - 28.4	Seldom experienced inland; trees uprooted; considerable structural damage occurs.	Very high waves; white streaks of foam; reduced visibility.
11	Violent storm	56 - 63	103 - 117	28.5 - 32.6	Very rare, widespread damage.	Exceptionally high waves able to hide medium sized ships from view, reduced visibility.
12	Hurricane	64 +	118 +	32.7 +	Devastating damage.	Sea completely white; air filled with foam and spray, very reduced visibility.

**F - MAINTENANCE**

**⚠ IMPORTANT ⚠**

*Your platform must be periodically inspected to ensure its continued compliance.  
The inspection frequency is defined by the legislation applying in the country in which the platform is used.  
In France, a general periodic inspection every 6 months (Decree of 1 March 2004).*



## INSTRUCTIONS FOR USING THE RADIO-CONTROL

For lift trucks with RC radio control

### HOW TO USE THE RADIO-CONTROL

#### SAFETY INSTRUCTIONS

- This radio-control consists of electronic and mechanical safety elements. It cannot receive commands from another transmitter because the internal encoding is unique to each radio-control.

**⚠ IMPORTANT ⚠**

*If it is used improperly or incorrectly, there is a risk of danger to:*

- *The physical and mental health of the user or others.*
- *The lift truck and other neighbouring items.*

*All those working with this radio-control:*

- *Must be qualified in line with current regulations and trained accordingly.*
- *Must follow this instruction manual as closely as possible.*

- The system is used to control the lift truck remotely via radio waves. Commands are also transmitted if the lift truck is out of sight (behind an obstacle or a building for example), this is why:
  - After stopping the truck and removing the key switch (only possible when it is stationary), always place the transmitter in a safe, dry place.
  - Before performing any installation, servicing or repair work, always switch off power sources (in particular, electric welding devices and electric head units on hydraulic distributors must be disconnected at each section).
  - Never remove or alter the safety devices (such as the hand-guard frame, key, emergency stop button, etc.).

**⚠ IMPORTANT ⚠**

*Never drive the lift truck if it is not continuously and perfectly within view of the operator!*

- Before leaving the transmitter, the operator must make sure that it cannot be used by an unauthorized third person: either by removing the key button from the transmitter or locking it in an inaccessible place.
- The user must ensure that the instruction manual is accessible at all times and that operators have read and understood it.

#### INSTRUCTIONS

- Take up position in a stable place with no risk of slipping.
- Before using the transmitter, make sure there is nobody within the working area.
- Only use the transmitter with its carrying device or installed correctly on the platform.

**⚠ IMPORTANT ⚠**

*When you remove the transmitter, remove the accumulator and key button so that it cannot be used accidentally or deliberately by anyone else.*

#### PROTECTIVE DEVICES

- The lift truck will be immobilised within a maximum of 450 milliseconds (approx. 0.5 second):
  - If the emergency stop button of the transmitter is pressed (50 milliseconds), or that of the lift truck.
  - If the transmission distance of the radio waves is exceeded.
  - If the transmitter is faulty.
  - If an interfering radio signal is received from elsewhere.
  - If the accumulator is removed from its housing in the transmitter.
  - If the battery reaches the end of its autonomy.
  - If the transmitter is switched off by turning the key switch to the off position.
- These protective devices are provided for the safety of personnel and property and must never be modified, removed or bypassed in any way whatsoever!
- The hand-guard frame prevents external action on a manipulator (e.g. if the transmitter is dropped, or if the operator leans on a guard-rail).
- An electronic safety device prevents radio transmission from being initiated if the manipulators are not mechanically and electrically at rest and if the internal combustion engine speed selector is not set to idle.

**⚠ IMPORTANT ⚠**

*In an emergency, press the transmitter emergency stop button immediately; then follow the manual's instructions (2 - DESCRIPTION: COMMAND AND CONTROL INSTRUMENTS).*



## LIFT TRUCK MAINTENANCE INSTRUCTIONS

### GENERAL INSTRUCTIONS

- Ensure the area is sufficiently ventilated before starting the lift truck.
- Wear clothes suitable for the maintenance of the lift truck, avoid wearing jewellery and loose clothes. Tie back and protect your hair, if necessary.
- Stop the engine and remove the ignition key, when an intervention is necessary.
- Read the operator's manual carefully.
- Carry out all repairs immediately, even if the repairs concerned are minor.
- Repair all leaks immediately, even if the leak concerned is minor.
- Ensure that process materials and of spare parts are disposed in all safely and in an ecological manner.
- Be careful of the risk of burns and splashing (exhaust, radiator, engine, etc.).

### PLACING THE BOOM SAFETY WEDGE

- The lift truck is equipped with a boom safety wedge (↖ 2 - DESCRIPTION: COMMAND AND CONTROL INSTRUMENTS) that must be installed on the rod of the lifting cylinder when working beneath the boom.

#### FITTING THE WEDGE

- Fully raise the boom.
- Place the safety wedge 1 on the rod of the lifting cylinder and secure with the rod 2 and the pin 3.
- Slowly lower the boom then stop the hydraulic movements before it comes into contact with the wedge.

#### REMOVING THE WEDGE

- Fully raise the boom.
- Remove the pin and the rod.
- Return the safety wedge to the storage location provided on the lift truck.

**⚠ IMPORTANT ⚠**

*Only use the wedge supplied with the lift truck.*

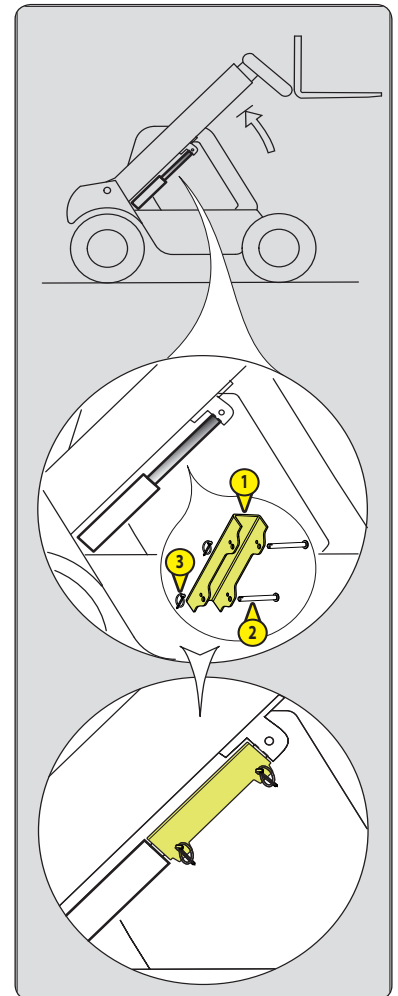

### MAINTENANCE

- Perform the periodic service (↖ 3 - MAINTENANCE) to keep your lift truck in good working condition. Failure to perform the periodic service may cancel the contractual guarantee.

#### MAINTENANCE LOGBOOK

- The maintenance operations carried out in accordance with the recommendations given in Part: 3 - MAINTENANCE and the other inspection, servicing or repair operations or modifications performed on the lift truck or its attachments are recorded in a maintenance logbook. The entry for each operation should include the date of the work, the names of the individuals or companies having performed them, the type of operation and its frequency, if applicable. The part numbers of any lift truck components that are replaced are indicated.



## **LUBRICANT AND FUEL LEVELS**

---

- Use the recommended lubricants (never use contaminated lubricants).
- Do not fill the fuel tank when the engine is running.
- Only fill up the fuel tank in areas specified for this purpose.
- Do not fill the fuel tank to the maximum level.
- Do not smoke or approach the lift truck with a flame, when the fuel tank is open or is being filled.

## **HYDRAULICS**

---

- Any work on the load handling hydraulic circuit is forbidden except for the operations described in Part: 3 - MAINTENANCE.
- Do not attempt to loosen connections, hoses or a hydraulic component with the circuit under pressure.

**⚠ IMPORTANT ⚠**

***BALANCING VALVE: It is dangerous to change the setting and remove the balancing valves or safety valves which may be fitted to your lift truck cylinders. The HYDRAULIC ACCUMULATORS that may be fitted on your lift truck are pressurised units. Removing these accumulators and their pipework is a dangerous operation and must only be performed by approved personnel (consult your dealer). These operations must only be performed by approved personnel (consult your dealer).***

## **ELECTRICITY**

---

- Do not short-circuit the starter relay to start the engine. If the forward/reverse selector is not in neutral and the parking brake is not applied, the lift truck may suddenly start to move.
- Do not place metal items on the battery.
- Disconnect the battery before working on the electrical circuit.

## **WELDING**

---

- Disconnect the battery before any welding operations on the lift truck.
- When carrying out electric welding work on the lift truck, connect the negative cable from the equipment directly to the part being welded, so as to avoid high tension current passing through the alternator.
- Never carry out welding or work which gives off heat on an assembled tyre. The heat would increase the pressure which could cause the tyre to explode.
- If the lift truck is equipped with an electronic control unit, disconnect this before starting to weld, to avoid the risk of causing irreparable damage to electronic components.

## **WASHING THE LIFT TRUCK**

---

- Clean the lift truck or at least the area concerned before any intervention.
- Remember to close and lock all accesses to the lift truck (doors, windows, cowls...).
- During washing, avoid the articulations and electrical components and connections.
- If necessary, protect against penetration of water, steam or cleaning agents, components susceptible of being damaged, particularly electrical components and connections and the injection pump.
- Clean the lift truck of any fuel, oil or grease trace.

## **TRANSPORTING THE LIFT TRUCK**

---

**⚠ IMPORTANT ⚠**

***Transporting the lift truck involves real risks for the operator and others involved.***

- Towing, winching, slinging or transporting the lift truck (< 3 - MAINTENANCE).



## IF THE LIFT TRUCK IS NOT TO BE USED FOR A LONG TIME

### INTRODUCTION

The following recommendations are intended to prevent the lift truck from being damaged when it is withdrawn from service for an extended period.

#### **⚠ IMPORTANT ⚠**

*Procedures to follow if the lift truck is not to be used for a long time and for starting it up again afterwards must be performed by your dealership.*

*This period of long-term stoppage must not exceed 12 months.*

*After 12 months, repeat the procedures for putting the lift truck back into service and long-term stoppage.*

### PREPARING THE LIFT TRUCK

- Clean the lift truck thoroughly.
- Check and repair any fuel, oil, water or air leaks.
- Replace or repair any worn or damaged parts.
- Wash the painted surfaces of the lift truck in clear and cold water and wipe them.
- Touch up the paintwork if necessary.
- Stop the lift truck (← OPERATING INSTRUCTIONS UNLADEN AND LADEN).
- Make sure the boom cylinder rods are all in the retracted position.
- Release the pressure in the hydraulic circuits.

### DEF (Diesel Exhaust Fluid) TANK

Depending on the model of lift truck

- Drain and rinse the DEF tank.
- Replace the "DEF" (Diesel Exhaust Fluid) supply pump filter (← 3 - MAINTENANCE).
- Slowly fill the tank with new "DEF" (Diesel Exhaust Fluid) up to the bottom of the filler neck.
- Start up the lift truck to pressurise the circuit and bring it up to working temperature, then shut down the engine.
- If necessary, top up the tank.

### PROTECTING THE ENGINE

- Contact your dealer to obtain the procedure for protecting the inside of the engine (use of protection product).
- Fill the tank with fuel (← 3 - MAINTENANCE).
- Drain and replace the coolant (← 3 - MAINTENANCE).
- Leave the engine running at idling speed for a few minutes, then switch off.
- Replace the engine oil and oil filter (← 3 - MAINTENANCE).
- Run the engine for a short time so that the oil and cooling liquid circulate inside.
- Disconnect the battery and store it in a safe place away from the cold, after charging it to a maximum.
- Block the outlet with waterproof adhesive tape.
- Remove the drive belts and store them in a safe place.
- Disconnect the engine cut-off solenoid on the injection pump and carefully insulate the connection.

### PROTECTING THE LIFT TRUCK

- Set the lift truck on axle stands so that the tyres are off the ground.
- Release the parking brake (depending on the model of lift truck).
- Protect cylinder rods which will not be retracted, from corrosion.
- Wrap the tyres.

NOTE: If the lift truck is to be stored outdoors, cover it with a waterproof tarpaulin.



## BRINGING THE LIFT TRUCK BACK INTO SERVICE

---

- Remove the waterproof adhesive tape from all the holes.
- Refit and reconnect the battery.
- Remove the protection from the cylinder rods.
- Perform the daily maintenance operations (↖ 3 - MAINTENANCE).
- Put the handbrake on and remove the axle stands.
- Drain and clean the fuel tank (↖ 3 - MAINTENANCE).
- Fill the fuel tank with clean diesel filtered through the filler port.
- Replace the fuel filter (↖ 3 - MAINTENANCE).
- Replace the fuel pre-filter (↖ 3 - MAINTENANCE) (depending on the model of lift truck).
- Drain and rinse the DEF tank (depending on the model of lift truck).
- Top up, slowly fill the tank with new "DEF" (Diesel Exhaust Fluid) up to the bottom of the filler neck (depending on the model of lift truck).
- Refit the drive belts and adjust the tension (↖ 3 - MAINTENANCE).
- Turn the engine over with the starter, to allow the oil pressure to rise.
- Reconnect the engine cut-off solenoid.
- Lubricate the lift truck completely (↖ 3 - MAINTENANCE).

**⚠ IMPORTANT ⚠**

*Ensure the area is sufficiently ventilated before starting the lift truck.*

- Start up the lift truck, following the safety instructions and regulations (↖ OPERATING INSTRUCTIONS UNLADEN AND LADEN).
- Carry out all the boom hydraulic movements, concentrating on the ends of travel for each cylinder.



## LIFT TRUCK DISPOSAL

### ⚠ IMPORTANT ⚠

*Please consult your dealer before disposing of your lift truck.*

### RECYCLING OF MATERIALS

#### METALS

- Metals are 100 % recoverable and recyclable.

#### PLASTICS

- Plastic parts are identified with a marking in accordance with current regulations.
- A limited range of materials is used to simplify the recycling process.
- The majority of plastic components are made of "thermoplastic" plastics, that are easily recycled by melting, granulating or grinding.

#### RUBBER

- Tyres and seals can be ground for use in cement manufacture or to obtain reusable granules.

#### GLASS

- Glass items can be removed and collected for processing by glaziers.

### ENVIRONMENTAL PROTECTION

By entrusting the maintenance of your lift truck to the MANITOU network, the risk of pollution is limited and the contribution to environmental protection contribution is made.

#### WORN OR DAMAGED PARTS

- Do not dump them in the countryside.
- MANITOU and its network have signed-up to a scheme of environmental protection through recycling.

#### USED OIL

- The MANITOU network organises the collection and processing of used oil.
- By handing over your waste oil to MANITOU, the risk of pollution is limited.

#### USED BATTERIES

- Do not throw away batteries, as they contain metals that are harmful for the environment.
- Return them to the MANITOU network or any other approved collection point.

NOTE: MANITOU seeks to manufacture lift trucks providing the best performance and limiting polluting emissions.



# 2 - DESCRIPTION





## 2 - DESCRIPTION

<b><u>CE DECLARATION OF CONFORMITY</u></b>		<b>2-4</b>
<b><u>SAFETY PLATES AND STICKERS</u></b>		<b>2-6</b>
<b><u>IDENTIFICATION OF THE LIFT TRUCK</u></b>		<b>2-10</b>
<b><u>CHARACTERISTICS</u></b>	MT 733...	<b>2-14</b>
<b><u>CHARACTERISTICS</u></b>	MT 933...	<b>2-16</b>
<b><u>CHARACTERISTICS</u></b>	MT 1033...	<b>2-18</b>
<b><u>TYRES</u></b>		<b>2-20</b>
<b><u>DIMENSIONS AND LOAD CHARTS</u></b>	MT 733...	<b>2-22</b>
<b><u>DIMENSIONS AND LOAD CHARTS</u></b>	MT 933...	<b>2-24</b>
<b><u>DIMENSIONS AND LOAD CHARTS</u></b>	MT 1033...	<b>2-26</b>
<b><u>VISIBILITY</u></b>	MT 733...	<b>2-28</b>
<b><u>VISIBILITY</u></b>	MT 933...	<b>2-30</b>
<b><u>VISIBILITY</u></b>	MT 1033...	<b>2-32</b>
<b><u>INSTRUMENTS AND CONTROLS</u></b>		<b>2-34</b>
<b><u>TOWING DEVICE</u></b>		<b>2-58</b>
<b><u>DESCRIPTION AND USE OF THE OPTIONS</u></b>		<b>2-60</b>

**CE DECLARATION OF CONFORMITY**

**1) DÉCLARATION «CE» DE CONFORMITÉ (originale)**  
**«EC» DECLARATION OF CONFORMITY (original)**

2) Constructeur, *Manufacturer* : **MANITOU BF**

3) Adresse, *Address* : **430, RUE DE L'AUBINIÈRE - B.P 10249**

**44158 - ANCENIS - CEDEX - FRANCE**

4) Titulaire de dossier technique, *Holder of the technical file* : **MANITOU BF**

3) Adresse, *Address* : **430, RUE DE L'AUBINIÈRE - B.P 10249**

**44158 - ANCENIS - CEDEX - FRANCE**

5) Le constructeur déclare que la machine décrite ci-après, *The manufacturer declares that the machine described below* :

<b>MT 733 EASY 75D ST5 S1</b>	<b>52001222/00000</b>	<b>N° &gt;MAN00000E000000000&lt;</b>
<b>MT 933 EASY 75D ST5 S1</b>	<b>52001233/00000</b>	<b>N° &gt;MAN00000E000000000&lt;</b>
<b>MT 1033 EASY 75D ST5 S1</b>	<b>52001237/00000</b>	<b>N° &gt;MAN00000E000000000&lt;</b>

6) Est conforme aux directives suivantes et à leurs transpositions en droit national (si applicables), *Complies with the following directives and their transpositions into national law (if applicable)* :

**2006/42/CE**

7) Pour les machines annexe IV, *For annex IV machines* :

8) Numéro d'attestation, *Certificate number* :

9) Organisme notifié, *Notified body* : -

**2000/14/CE + 2005/88/CE**

10) Procédure appliquée, *Applied procedure* :

9) Organisme notifié, *Notified body* :

11) Niveau de puissance acoustique, *Sound power level* :

12) Mesuré, *Measured* : dB (A)

13) Garanti, *Guaranteed* : dB (A)

**2004/108/CE jusqu'au 19/04/2016 et 2014/30/UE à partir du 20/04/2016**

14) Normes harmonisées utilisées, *Harmonised standards used* :

15) Normes ou dispositions techniques utilisées, *Standards or technical provisions used* :

16) Fait à, *Done at* :

17) Date, *Date* :

18) Nom du signataire, *Name of signatory* :

19) Fonction, *Function* :

20) Société, *Company* :

21) Signature, *Signature* :



**bg :** (1) „ЕО“ декларация за съответствие (оригинал), (2) Производител, (3) Адрес, (4) Приемател на техническото досие, (5) Производител декларира, че описаната по-долу машина, (6) Е в съответствие със следните директиви и техните транспонирани в националното законодателство (ако е приложимо), (7) Приложение IV относно машините, (8) Номер на сертификата, (9) Нотифициран орган, (10) Приложение процедура, (11) Име на силата на звука, (12) Измерено, (13) Гаражиране, (14) Използвани хармонизирани стандарти, (15) Използвани стандарти или технически разпоредби, (16) Уработоно а, (17) Дата, (18) Име на подписаното лице, (19) Длъжност, (20) Фирма, (21) Подпис

**cs :** (1) ES prohlášení o shodě (původní), (2) Výrobce, (3) Adresa, (4) Držitel technické dokumentace, (5) Výrobce prohlašuje, že zařízení popsané níže, (6) Je v souladu s následujícími směrnici a směrnici transponovanými do vnitrostátního práva (je-li relevantní), (7) Pro stroje v příloze IV(B) Číslo certifikátu, (8) Notifikační orgán, (9) Použitý postup, (10) Úroveň hluku (12) Naměřená, (13) Zaručená, (14) Použité harmonizované normy, (15) Použité normy nebo technické předpisy (16) Město (17) Datum (18) Jméno podepsaného, (19) Funkce, (20) Společnost, (21) Podpis

**da :** (1) EF Overensstemmelseserklæring (original), (2) Producent, (3) Adresse, (4) Indehaver af det tekniske dossier, (5) Producenten erklærer, at maskinen, der er beskrevet nedenfor, (6) Overholder nedenstående direktiver og derafs gennemførelse til national ret (hvis det er relevant), (7) For maskiner under bilag IV, (8) Certifikat nummer, (9) Bemyndigede organ, (10) Anvendt procedure, (11) Lydeffektivitet, (12) Målt, (13) Garanti, (14) Anvendte harmoniserede standarder, (15) Standarder efter tekniske regler, (16) Udfærdiget i, (17) Dato, (18) Underskrifters navn, (19) Funktion, (20) Firma, (21) Underskrift

**de :** (1) EG-Konformitätsbescheinigung (original), (2) Hersteller, (3) Adresse, (4) Inhaber des technischen Dokuments, (5) Der Hersteller erklärt, dass die nachstehend beschriebene Maschine (6) den folgenden Richtlinien und deren Umsetzung in die nationale Gesetzgebung entspricht (falls anwendbar), (7) Für die Maschinen laut Anhang IV, (8) Bescheinigungsnummer, (9) Benannte Stelle, (10) Angewandtes Verfahren, (11) Gemessene, (12) Gemessen, (13) Gewährleistung, (14) angewandte harmonisierte Normen, (15) angewandte sonstige technische Normen und Bestimmungen, (16) Ausgestellt in, (17) Datum, (18) Name des Unterzeichners, (19) Funktion, (20) Gesellschaft, (21) Unterschrift

**el :** (1) Δήλωση συμμόρφωσης CE (πρωτότυπο), (2) Κατασκευαστής, (3) Διεύθυνση, (4) Κάτοχος του τεχνικού φακέλου, (5) Ο κατασκευαστής δηλώνει ότι το μηχάνημα που περιγράφεται παρακάτω, (6) Συμμορφώνεται με τις ετήσιες οδηγίες και τις προσαρμογές τους στο εθνικό δίκαιο (κατά περίπτωση), (7) Για τα μηχανήματα που παραρτήματα IV, (8) Αριθμός πιστοποίησης, (9) Διευθυντής φορέα, (10) Εφαρμοζόμενη διαδικασία, (11) Στάθμη ηχητικής ισχύος, (12) Καταμετρήσεις, (13) Εγγυημένη, (14) Εναρμονισμένο πρότυπο που χρησιμοποιούνται, (15) Πρότυπα ή τεχνικά κανόνες που χρησιμοποιούνται, (16) Τόπος, (17) Ημερομηνία, (18) Όνομα του υπαγράφοντα, (19) Ιδιότητα, (20) Εταιρεία, (21) Υπογραφή

**es :** (1) Declaración CE de conformidad (original), (2) Fabricante, (3) Dirección, (4) Titular del expediente técnico, (5) El fabricante declara que la máquina que se describe a continuación, (6) Cumple con las siguientes directivas y sus transposiciones a la legislación nacional (en caso oportuno), (7) Para las máquinas anexo IV, (8) Número de certificación, (9) Organismo notificado, (10) Procedimiento aplicado, (11) Nivel de potencia acústica, (12) Medido, (13) Garantizado, (14) Normas armonizadas utilizadas, (15) Otras normas o especificaciones técnicas utilizadas, (16) Hecho en, (17) Fecha, (18) Nombre del signatario, (19) Cargo, (20) Empresa, (21) Firma

**et :** (1) EÜ vastavusdeklaratsioon (algupärane), (2) Tootja, (3) Aadress, (4) Tehnilise dokumentatsiooni hoidja, (5) Tootja kirjutab, et allpool kirjeldatud seade, (6) On vastavuses järgmistele direktiivide ja nende reguleerimises õigusse ülevõtmiseks vastavõetud õigusaktidega (kui on kohaldatav), (7) IV lisas loetletud seadmete puhul, (8) Tunnistus number, (9) Serifitseerimisasutus, (10) Kohaldatud menetlus, (11) Akustiline võimsuse tase, (12) Mõeldud, (13) Tagatud, (14) Vastab kehtivale ühtlustatud standarditele, (15) Vastab muudele kehtivale standarditele ja tehnilistele normidele, (16) Väljaandmise koht, (17) Väljaandmise aeg, (18) Allkirjastaja nimi, (19) Amet, (20) Ettevõtte, (21) Allkiri

**fi :** (1) EY-vaatamustunnustuskäytösvaltuutus (alkuperäinen), (2) Valmistaja, (3) Osoite, (4) Teknisten asiakirjojen haltaja, (5) Valmistaja ilmoittaa, että alla kuvattu laite, (6) Täyttää seuraavien direktiivien sekä niitä vastaavien kansallisten säätöjen vaatimukset (tarvittaessa), (7) Liitteen IV listoiden osalla, (8) Todistusnumero, (9) Ilmoitettu laitos, (10) Käytetty menetelmä, (11) Äänen tehotaso, (12) Mittattu, (13) Taattu, (14) Käytetyt yhdenmukaistetut standardit, (15) Käytetyt tekniset standardit tai säännökset, (16) Paikka, (17) Aika, (18) Allekirjoittajan nimi, (19) Toimi, (20) Yritys, (21) Allekirjoitus

**ga :** (1) Déarbairtá comhréireachta CE (bunleábh), (2) Déantóir, (3) Seoladh, (4) Sealtbhóir an chomhad teicniúil, (5) Dearnbhóir an deantóir go ndéanann an t-ineall ar a bfuil ar sios blios, (6) Cloíonn sé le na teoracha seo a leanas agus lena dtionscail isteach i n-áil náisiúna (má cuibíonn), (7) Le haghaidh innéil an agaisín IV, (8) Uimhir teastais, (9) Comhriacht a dtagair fógra dó, (10) Níos ineaithne a cuireadh i bhfeidhm, (11) Leibhéal cumhachta na fuaimne, (12) Tomhasa, (13) Rialúcháin, (14) Cairdeáil chomhréireachta a úsáidídh, (15) Cairdeáil nó fórlacha teicniúla a úsáidídh, (16) Ama dhéanann ag, (17) Dáta, (18) Ainm an tseoltóra, (19) Feidhmeánas, (20) Comhriacht (21) Síniú

**hr :** (1) EK deklaracija o usklađenosti (original), (2) Proizvođač, (3) Adresa, (4) Nositelj tehničke dokumentacije, (5) Proizvođač izjavljuje da stroj opisan u nastavku, (6) Ispunjava sljedeće direktive i njihovom primjeni u nacionalno zakonodavstvo (ako je primjenjivo), (7) Za dodatke IV e strojevima, (8) Broj certifikata, (9) Ovlašteno tijelo, (10) Primjenjeni postupak, (11) Razina snage zvuka, (12) Izmjereno, (13) Zajamčeno, (14) Primjenjeni standardi u harmoniziranju, (15) Primjenjeni standardi ili tehničke priloge, (16) Urađeno u, (17) Datum, (18) Ime potpisnika, (19) Funkcija, (20) Tvrtka, (21) Potpis

**hu :** (1) CE megfelelőségi nyilatkozat (eredeti), (2) Gyártó, (3) Cím, (4) A műszaki dokumentáció birtokosa, (5) A gyártó kijelenti, hogy az alábbi termék, (6) Megfelel az alábbi irányelveknek valamint azok honosított előírásainak (ha vannak ilyenek), (7) A IV. melléklet gépeihez (adott esetben), (8) Bizonylati szám, (9) Értékelést szerzőzet, (10) Akkreditált eljárás, (11) Akusztikus hang szint, (12) Mérés, (13) Garancia, (14) Felhasznált harmonizált szabványok, (15) egyéb felhasznált műszaki szabványok és előírások hivatkozásai, (16) Kelt (hely), (17) Dátum, (18) Aláíró neve, (19) Funkció, (20) Vállalat, (21) Aláírás

**is :** (1) Samþykkingarvottun ESB (upprunaleg), (2) Framleiðandi, (3) Aðilar, (4) Handhafi tekniskrár, (5) Framleiðandi staðfestir að völin sem lýst er hér, (6) Samræmist eflirarandi stöðlum og staðfarum þeirra með hlífðun af bjóðandi (ef við á), (7) Fyrir tekið á við í IV. viðauka, (8) Númer vottora, (9) Tilkynnt til, (10) Aðferð bális, (11) Hljóstyrkur, (12) Mældist, (13) Ábyrgð, (14) Samhæfir staðlar sem notaðir voru, (15) Aðrir staðlar eða tekniskar forskriftir, (16) Staður, (17) Dagssetning, (18) Nafn undirritaðs, (19) Staða, (20) Fyrirtæki, (21) Underskrift

**it :** (1) Dichiarazione CE di conformità (originale), (2) Costruttore, (3) Indirizzo, (4) Titolare del fascicolo tecnico, (5) Il costruttore dichiara che la macchina descritta di seguito, (6) È conforme alle direttive seguenti e ai relativi recepimenti nella normativa nazionale (se applicabile), (7) Per le macchine Allegato IV, (8) Numero di Attestazione, (9) Organismo designato della notifica, (10) Procedura applicata, (11) Livello di potenza acustica, (12) Misurato, (13) Garantito, (14) Norme armonizzate applicate, (15) Norme e specifiche tecniche applicate, (16) Luogo, (17) Data, (18) Nome del firmatario, (19) Funzione, (20) Società, (21) Firma

**lt :** (1) EC atitikties deklaracija (originalas), (2) Gamintojas, (3) Adresas, (4) Techninės bylos turėtojas, (5) Gamintojas nurodo, kad mašina, aprašyta žemiau, (6) Atitinka toliau nurodytas direktyvas ir / nacionalinius teisės aktus perkeltas į nuostatas (jei taikytina), (7) IV priede dalyje mašinų, (8) Serifikacijos Nr., (9) Notifikuotai įstaiga, (10) Taikytą procedūrą, (11) Garso slėpumo lygis, (12) Izmērēts, (13) Garantēts, (14) Naudojami standartai ir techninės specifikacijos, (15) Kiti naudojami standartai ir techninės specifikacijos, (16) Pasirašyta, (17) Data, (18) Pasirašiusio asmens vardas ir pavardė, (19) Pareigos, (20) Bendrovė, (21) Paraišas

**lv :** (1) EK atbilstības deklarācija (oriģināla), (2) Ražotāja, (3) Adrese, (4) Tehniskās dokumentācijas turētājs, (5) Ražotāja apliecina, ka turpmāk aprakstītā mašīna, (6) Atbilst šādiem norādītajiem direktīvu un to iekļautajai nacionālajai likumdošanai (ja piemērojama), (7) IV pielikuma iekārtām, (8) Serifikācija numurs, (9) Pārbaudītā iestāde, (10) Piemērotā procedūra, (11) Starpskaņas jaudas līmenis, (12) Izmērīts, (13) Garantēts, (14) Piemērotajām standartu grupām, (15) Piemērotajām tehniskajiem standartu un noteikumiem, (16) Sasīdīts, (17) Datums, (18) Parakstītāja vārds, (19) Amats, (20) Uzņēmums, (21) Paraksts

**mt :** (1) Deklarazzjoni ta' Konformità tal-KE (originali), (2) Manifattur, (3) Indirizz, (4) Detentur tal-fajl tekniku, (5) Il-manifattur jiddeklara li l-magna deskribta hawn taħt, (6) Hija konformi hija konformi mad-Direttivi segwenti u l-lijiet li jipprezentawhom fil-KE nazzjonali (jekk applikabbli), (7) Għall-magna fl-Anness IV, (8) Numru ta-Certifikat, (9) Entità notifikata, (10) Proċedura applikata, (11) Livell ta' gawwa akustika, (12) Imkeġel, (13) Garantit, (14) L-istandards armonizzati użati, (15) standards tekniku u speċifikazzjonijiet oħra użati, (16) Magħmul f, (17) Data, (18) Isem il-Manifattur, (19) Karteg, (20) Kumpanija (21) Firma

**nl :** (1) EG-verklaring van overeenstemming (oorspronkelijk), (2) Fabrikant, (3) Adres, (4) Houder van het technisch dossier, (5) De fabrikant verklaart dat de hieronder beschreven machine, (6) In overeenstemming is met de volgende richtlijnen en hun omzettingen in het nationale recht (indien van toepassing), (7) Voor de machines in bijlage IV, (8) Certificatnummer, (9) Aangemelde instantie, (10) Toegespte procedure, (11) Geluidsvermogensniveau, (12) Gemeten, (13) Gegarandeerd, (14) gehanteerde geharmoniseerde normen, (15) andere gehanteerde technische normen en specificaties, (16) Opgegeven in, (17) Datum, (18) Naam van ondergetekende, (19) Functie, (20) Onderneming, (21) Handtekening

**no :** (1) CE-samsvarserklæring (original), (2) Producent, (3) Adresse, (4) Innehaveren av den tekniske dokumentasjonen, (5) Produzenten sier at maskinen beskrevet nedenfor, (6) Oppfylder kravene i følgende direktiver og med nasjonale gjennomføringsbestemmelser (hvis aktuelt), (7) For maskinene i bilag IV, (8) Attestnummer, (9) Teknisk kontrollorgan, (10) Anvendt prosedyre, (11) Akustisk styrke, (12) Målt, (13) Garantert, (14) harmoniserte standarder som brukes, (15) Andre standarder og spesifikasjoner som brukes, (16) Utstedt, (17) Dato, (18) Undertegnedes navn, (19) Stilling, (20) Firma (21) Underskrift

**pl :** (1) Deklaracja zgodności CE (oryginał), (2) Producent, (3) Adres, (4) Posiadacz dokumentacji technicznej, (5) Producent oświadcza, że opisana poniżej maszyna, (6) Jest zgodna z następującymi dyrektywami i odpowiedziami im przepisami prawa krajowego (jeżeli dotyczy), (7) Dla maszyny załącznik IV, (8) Numer certyfikatu, (9) Jednostka notyfikująca, (10) Procedura stosowana, (11) Poziom mocy akustycznej, (12) Zmierzone, (13) Gwarantowane, (14) zastosowane normy zharmonizowane, (15) Zastosowanie normy lub przepisy techniczne, (16) Sporządzono w, (17) Data, (18) Nazwisko podpisującego, (19) Stanowisko, (20) Firma (21) Podpis

**pt :** (1) Declaração de conformidade CE (original), (2) Fabricante, (3) Morada, (4) Titular do processo técnico, (5) O fabricante afirma que a máquina descrita abaixo, (6) Está em conformidade com as seguintes diretivas e as suas transposições para o direito nacional (se for o caso), (7) Para as máquinas no anexo IV, (8) Número de certificado, (9) Entidade notificada, (10) Procedimento aplicado, (11) Nível de potência acústica, (12) Medida, (13) Garantida, (14) normas harmonizadas utilizadas, (15) outras normas e especificações técnicas utilizadas, (16) Elaborado em, (17) Data, (18) Nome do signatário, (19) Cargo, (20) Empresa, (21) Assinatura

**ro :** (1) Declarație de conformitate CE (originală), (2) Producător, (3) Adresă, (4) Titularul din dosarul tehnic, (5) Producătorul afirmă că aparatul descris mai jos, (6) Este conform cu directivele următoare și cu transpunerile lor în dreptul național (dacă este cazul), (7) Pentru mașinile din anexa IV, (8) Număr de atestare, (9) Organism notificat, (10) Procedură aplicată, (11) Nivel de putere acustică, (12) măsurată, (13) garantată, (14) standardele armonizate utilizate, (15) alte standarde și specificații tehnice utilizate, (16) înlocuit în, (17) Data, (18) Numele persoanei care semnează, (19) Funcția, (20) Firma, (21) Semnătură

**sk :** (1) Vyhlásenie o zhode ES (pôvodné), (2) Výrobca, (3) Adresa, (4) Držiteľ technickej dokumentácie, (5) Výrobca vyhlasuje, že nižšie popísaný stroj, (6) Je v súlade s nasledujúcimi smernicami a smernicami transponovanými do vnútroštátneho práva (v prípade potreby), (7) Pre stroje v prílohe IV, (8) Číslo certifikátu, (9) Notifikovaný orgán, (10) Použitý postup, (11) Akustická úroveň hluku, (12) Naměřená, (13) Zaručená, (14) Použité harmonizované normy, (15) Iné použité normy a technické predpisy, (16) Miesto vydania, (17) Dátum vydania, (18) Meno podpísaného, (19) Funkcia, (20) Spoločnosť, (21) Podpis

**sl :** (1) ES izjava o skladnosti (izvirnik), (2) Proizvajalec, (3) Naslov, (4) Imetnik tehnične dokumentacije, (5) Proizvajalec izjavlja, da naprava, opisana v nadaljevanju, (6) Ustreza naslednjim direktivam in nacionalni zakonodaji (če ta velja), (7) Za stroje v skladu s prilogo IV, (8) Številka potrdila, (9) Pregledni organ, (10) Uporabljen postopek, (11) Raven akustične moči, (12) Izmerjeno, (13) Zajamčeno, (14) Uporabljeni usklajeni standardi, (15) Drugi uporabljeni tehnični standardi in specifikacije, (16) V, (17) Datum, (18) Ime podpisnika, (19) Funkcija, (20) Podjetje, (21) Podpis

**sv :** (1) EG-förklarande om överensstämmelse (original), (2) Tillverkare, (3) Adress, (4) Ägaren av det tekniska underlaget, (5) Tillverkaren försäkras att den maskin som beskrivs nedan, (6) Överensstämmer med nedanstående direktiv och införlivandet av dem i nationell rätt (om tillämpligt), (7) För maskinerna i bilaga IV, (8) Nummer för godkännande, (9) Anmält organ, (10) Förfarande som tillämpats, (11) Lydningsnivå, (12) Uppmätt, (13) Garanterad, (14) Harmoniserade standarder som använts, (15) andra tekniska standarder och specifikationer som använts, (16) Upprättat i, (17) Datum, (18) Namn på den som undertecknat, (19) Befattning, (20) Företag (21) Namnteckning



## SAFETY PLATES AND STICKERS

### ⚠ IMPORTANT ⚠

Clean all stickers and safety plates so that they are legible.  
Any safety plates and stickers which are illegible or damaged must be replaced.  
Check that stickers and safety plates are present after replacing any spare parts.

### EXTERNAL PLATES AND STICKERS

REF.	PART No.	DESCRIPTION
1	24653	- Slings point
2	52563320	- Tie-down point
3	234798	- Hydraulic oil
4	296998	- Safety instruction
5	234805	- Hydraulic coupling instruction (OPTION)
6	52567646	- Emergency output
7	288174	- Accumulator instructions
8	307508	- Battery cut-off instruction
9	305405	- Fuel instruction
10	52552739	- Air conditioning (OPTION)
11	256513	- Boom electrical predisposition (OPTION)
12	250707	- Fan reversal (OPTION)

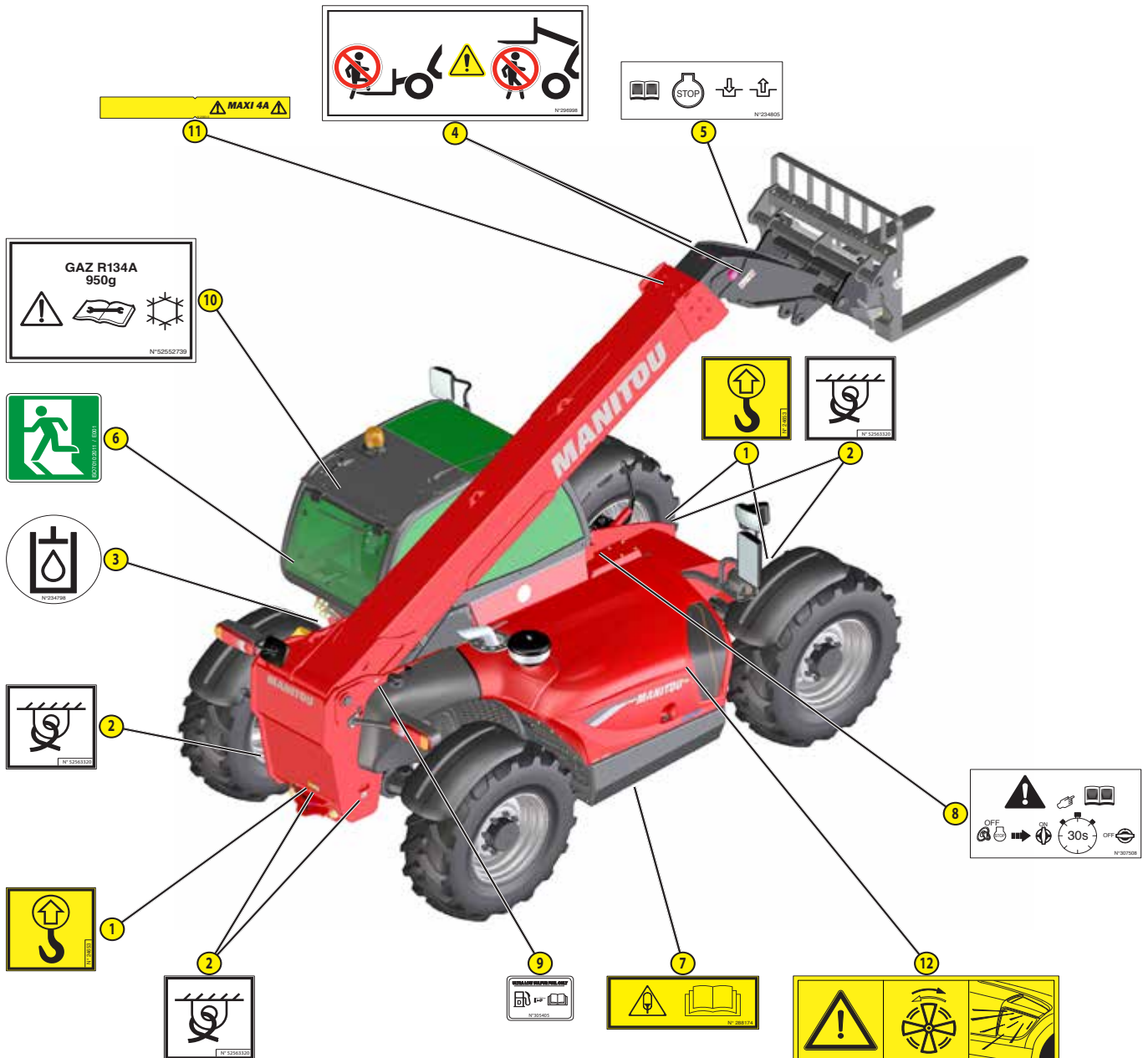



**STICKERS AND PLATES UNDER THE ENGINE HOOD**

REF.	PART No.	DESCRIPTION
1	52501046	- Anti-freeze
2	259398	- Water/diesel separator
3	52621006	- Engine fuse
4	233088	- Preheat rod (OPTION)

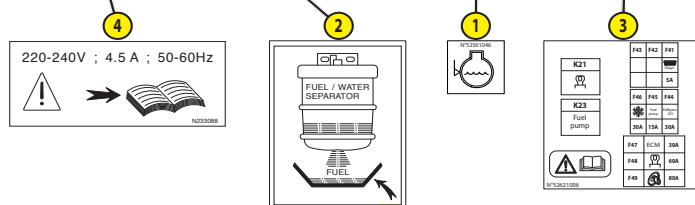
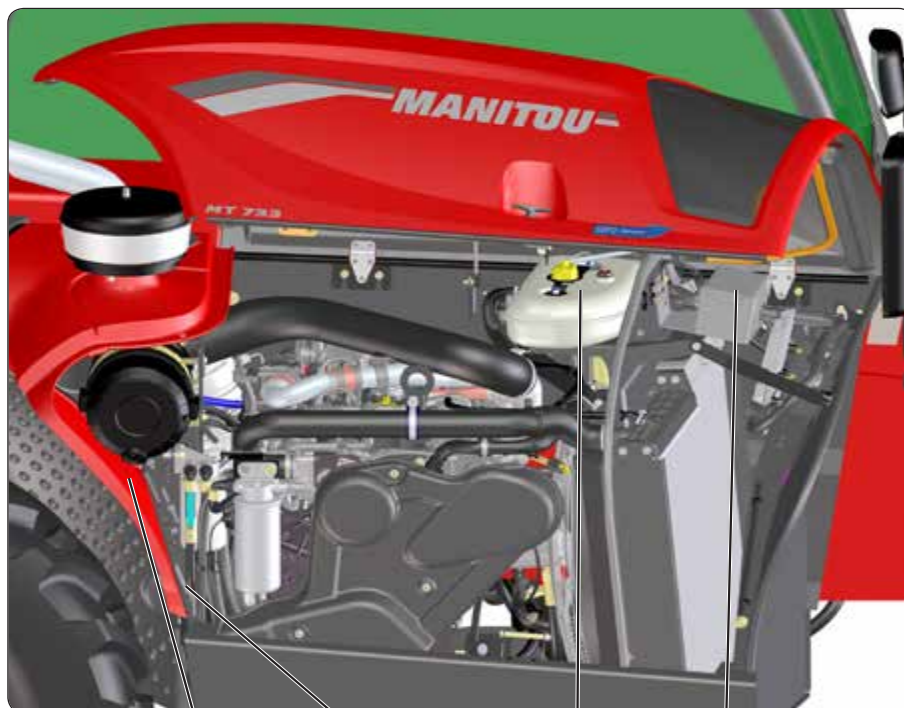



**PLATES AND STICKERS IN THE CAB**

REF.	PART No.	DESCRIPTION
1	193032	- Cab compliance
2	223324	- Patents
3	33460	- Gear selection
4	239594	- Sound power 104 dB
5	184276	- Steering selection control
6	290183	- Bucket instruction on telescope
7	268491	- Brake fluid instruction
8	52653778	- Fuses
9	52503175	- Reach chart sheet
10	241621	- Safety instruction
11	272040	- Transmission cut-off switch function
12	286277	- Joystick function MT 733... - MT 933...
13	52552257	- Joystick function MT 1033...
14	294831	- Resetting procedure MT 733... - MT 933...
15	295054	- Resetting procedure MT 1033...
16	52599676	- Lubrication sheet
17	297733	- Operating mode management instruction
18	52527269	- Consumption sheet MT 733...
19		- Consumption sheet MT 933...
20		- Consumption sheet MT 1033...
21	52651762	- Hydraulic controls activation
22	52655274	- Load chart for lifting ring on single carriage
23	265284	- Lifting ring on single carriage (OPTION)
24	52523027	- Load chart for lifting ring on single carriage (OPTION) MT 733...
25	52523028	- Load chart for lifting ring on single carriage (OPTION) MT 933...
26	266915	- Load chart for lifting ring on single carriage (OPTION) MT 1033...

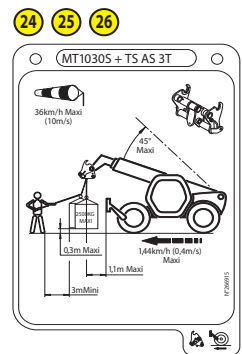
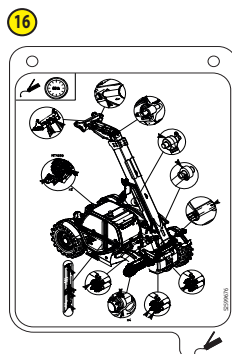
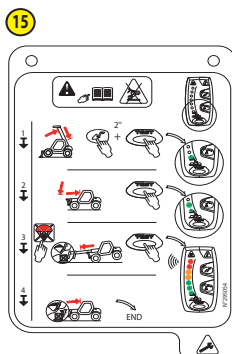
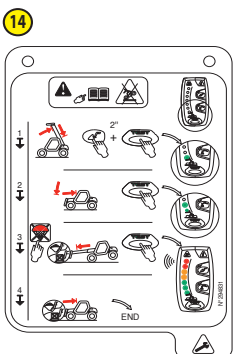
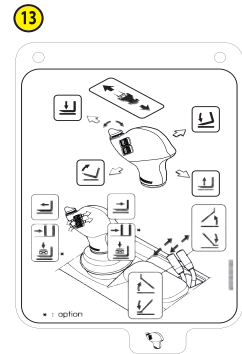
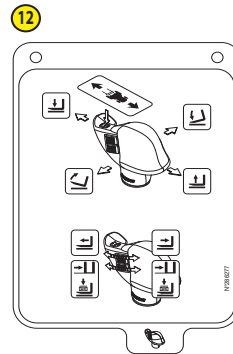
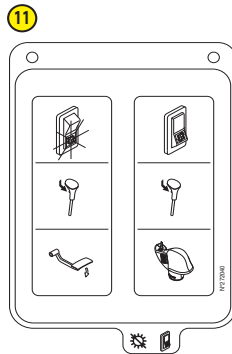
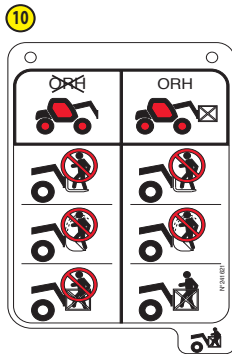



21

52651762

17

STANDARD BUCKLE

6

OK

23

PROHIBÉ

22

2 sec

WAIT 40-50 min

N°2655274

5

2 sec

3

LWA

**104dB**

239594

1

CABINE CONFORME A:  
CAB CONFORMS TO:

FOPS-ISO 3448  
ROPS-ISO 3471  
ANSI B 56.6

N°195932

2

BREVETS - PATENTS

FR 02 34807  
EP 0 656 315  
US PENDING

N°20281

7

HUILE MINERALE Uniquement  
MINERAL OIL ONLY  
MINERALÖL Nur  
ACEITE MINERAL Solamente  
OLIO MINERALE Soltanto

LHMS

N°265491

8



## IDENTIFICATION OF THE LIFT TRUCK

As our policy is to promote a constant improvement in our products, our range of lift trucks may undergo certain modifications, without any obligation for us to advise our customers.

When you order parts, or when you require any technical information, always specify the following information.

NOTE: For the owner's convenience, it is recommended that a note of these numbers is made in the spaces provided, at the time of the delivery of the lift truck.

For any further technical information regarding your lift truck refer to: CHARACTERISTICS.

### LIFT TRUCK MANUFACTURER'S PLATE

"Designation" Designation	
"Series" Series	
"Year of manufacture" Year of manufacture	
"Model year" Model year	
"Serial Number / Product Identification Number" Serial number/Product identification number	
"Unladen mass" Unladen weight	
"Power" Power	
"Authorized gross vehicle weight" Authorised gross vehicle weight	
"Rated capacity" Rated capacity	
"Max vertical force (on trailer hook)" Maximum vertical force (on towing hook)	
"Drag strain" Pulling force	



### ENGINE

"MODEL" Model	
"CODE" Code	
"E1" Identification	
"SERNO" Serial number	
"SPEC" Specification	

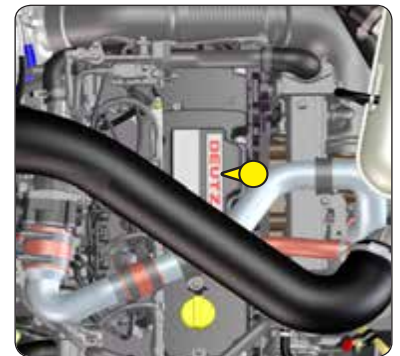

### GEARBOX

MANITOU Part No.	
Type	
Serial number	





**ANGLE GEAR-BOX**

MANITOU Part No.	
Type	
Serial number	



**FRONT AXLE**

Type	
Serial number	
MANITOU Part No.	



**REAR AXLE**

Type	
Serial number	
MANITOU Part No.	



**CAB**

"Constructeur" Manufacturer	
"Type Cabine" Cabin type	
"N° de série" Serial number	



**BOOM**

MANITOU Part No.	
Date of manufacture and manufacturer	





**FRAME**

Serial number/Product identification number	
---	--



**ATTACHMENT MANUFACTURER'S PLATE**

"MODELE" Model	
"N° série" Serial number	
"Année Fabrication" Year of manufacture	
"Masse à vide" Unladen weight	
"Centre de gravité" Centre of gravity	
"Capacité Nominale" Rated capacity	
"Pression service" Working pressure	







**CHARACTERISTICS** MT 733...

<b>ENGINE</b>		
Type		DEUTZ TD3.6L/2501-2848
Fuel		Diesel
Number of cylinders		4 in line
Suction		Supercharged
Injection system		Direct
Ignition sequence		1.3.4.2
Capacity	cm <sup>3</sup>	3621
Bore and stroke	mm	98 x 120
Compression ratio		18:1
Nominal speed laden	rpm	2200
Min. rpm unladen	rpm	930
Max. rpm unladen	rpm	2360
Power ISO/TR 14396	hp - kW	75 - 55,4
Power SAE J 1995	hp - kW	75 - 55,4
Maximum torque ISO/TR 14396	Nm	340 at 1,600 rpm
Air filtration efficiency	%	99,9
Type of cooling		By water
Fan		Puller

<b>TRANSMISSION</b>		
Gearbox		TURNER
- Type		Mechanical
- Reversing shift		Electro-hydraulic
- Torque converter		SACHS
- Number of forward speeds		4
- Number of reverse speeds		4
Angle gear box		TURNER
Front axle		DANA
- Differential		Limited slip
Rear axle		DANA
- Differential		Without locking
Drive wheels		Permanent 4 WD
- 2/4 wheel drive control		No
Front tyres		ALLIANCE
- Size		400/80-24 A325 162A8 ATG
- Pressure	bar	3
Rear tyres		ALLIANCE
- Size		400/80-24 A325 162A8 ATG
- Pressure	bar	3

<b>ELECTRIC CIRCUIT</b>		
Battery	STANDARD	12 V - 180 Ah - 900 A EN
	OPTION	12 V - 180 Ah - 1235 A EN
Alternator		14V - 95 A
- Type		ISKRA AAK3869
Starter		12 V - 3,2 kW
- Type		ISKRA AZE4668

<b>BRAKE SYSTEM</b>		
Service brake		Hydraulic power brake
- Type of brake		Oil-immersed multi-disc brake
- Type of control		Foot-operated for the front and rear axles
Parking brake		Mechanical
- Type of brake		Disk on gear-box output
- Type of control		Manual

<b>SOUND AND VIBRATION</b>		
Sound pressure level in the driver's cab LpA (according to standard NF EN 12053)	dB(A)	79 (cab closed); xx (cab open)
Sound pressure (according to Directive 2009/76)	dB(A)	xx (cab closed); xx (cab open)
Sound pressure level ensured in the LwA environment (according to Directive 2000/14/EC modified by Directive 2005/88/EC)	dB(A)	104 (measured); 104 (guaranteed)
Sound level in motion (according to Directive 2009/63)	dB(A)	xx
Average weighted acceleration on driver's body (according to standard NF EN 13059)	m/s <sup>2</sup>	1,1
The average weighted acceleration transmitted to the driver's hand/ arm system (according to standard ISO 5349-2)	m/s <sup>2</sup>	< 2,5
Standard seat vibration	m/s <sup>2</sup>	xx (lightweight operator); xx (heavyweight operator)



<b>HYDRAULIC CIRCUIT</b>			
Hydraulic pump		Gear pump with flow divider	
- Type		1st casing	2nd casing
- Capacity	cm <sup>3</sup>	39	21
- Max. rating capacity unladen	ℓ/min	93	50
- Flow rate at 1,600 rpm	ℓ/min	63	34
Filtration			
- Return	µm	10	
- Suction	µm	125	
Maximum service pressure		260	
- Telescoping circuit	bar	190 / 260	
- Lifting circuit	bar	260 / 260	
- Tilting circuit	bar	260 / 190	
- Attachment circuit (OPTION)	bar	260	
- Steering circuit	bar	140	

<b>HYDRAULIC MOVEMENTS</b>			
Longitudinal stability limiter and warning device		Electronic	
Lifting motions (boom retracted)			
- Unladen lifting	s - m/min	8,3 - 32,5	
- Laden lifting	s - m/min	9 - 30	
- Unladen lowering	s - m/min	6 - 45	
- Laden lowering	s - m/min	6,1 - 44,3	
Telescoping motions (boom raised)			
- Unladen extending	s - m/min	7,3 - 21,6	
- Laden extending	s - m/min	7,5 - 22,2	
- Unladen retracting	s - m/min	4,5 - 36	
- Laden retracting	s - m/min	4,6 - 35,2	
Tilting movements			
- Unladen digging	s - °/s	3,4 - 42,9	
- Unladen discharging	s - °/s	2,8 - 52,1	

<b>SPECIFICATIONS AND WEIGHTS</b>			
Speed of movement for lift truck in standard configuration on flat ground (except in specific conditions)			
- Front unladen	1	km/h	4,4
	2	km/h	7,4
	3	km/h	15
	4	km/h	26,4
- Rear unladen	1	km/h	4,4
	2	km/h	7,4
	3	km/h	15
	4	km/h	26,4
Standard attachment		TFF 35 MT 1040	
- Weight of attachment (without forks)	kg	165	
- Weight of forks (each)	kg	67,5	
Rated capacity with standard attachment	kg	3300	
Tipping load at maximum reach on tires	kg	1100	
Distance from the centre of gravity of the load to the base of the forks	mm	500	
Standard lifting height	mm	6900	
Lift truck weight without attachment	kg	6400	
Weight of lift truck with standard attachment			
- Unladen	kg	6700	
- At rated load	kg	10000	
Weight per axle with standard attachment (transport position)			
- Front unladen	kg	3290	
- Rear unladen	kg	3410	
- Front rated load	kg	8730	
- Rear rated load	kg	1270	
Weight per axle with standard attachment (boom extended)			
- Front rated load	kg	7210	
- Rear rated load	kg	590	
Drag strain on the coupling hook			
- Unladen (sliding)	daN	5510	
- At rated load (transmission setting)	daN	8360	
Break-out force with bucket (according to standard ISO 8313)	daN	5770	



**CHARACTERISTICS** MT 933...

<b>ENGINE</b>		
Type		DEUTZ TD3.6L/2501-2848
Fuel		Diesel
Number of cylinders		4 in line
Suction		Supercharged
Injection system		Direct
Ignition sequence		1.3.4.2
Capacity	cm3	3621
Bore and stroke	mm	98 x 120
Compression ratio		18:1
Nominal speed laden	rpm	2200
Min. rpm unladen	rpm	930
Max. rpm unladen	rpm	2360
Power ISO/TR 14396	hp - kW	75 - 55,4
Power SAE J 1995	hp - kW	75 - 55,4
Maximum torque ISO/TR 14396	Nm	340 at 1,600 rpm
Air filtration efficiency	%	99,9
Type of cooling		By water
Fan		Puller

<b>TRANSMISSION</b>		
Gearbox		TURNER
- Type		Mechanical
- Reversing shift		Electro-hydraulic
- Torque converter		SACHS
- Number of forward speeds		4
- Number of reverse speeds		4
Angle gear box		TURNER
Front axle		DANA
- Differential		Limited slip
Rear axle		DANA
- Differential		Without locking
Drive wheels		Permanent 4 WD
- 2/4 wheel drive control		No
Front tyres		ALLIANCE
- Size		400/80-24 A325 162A8 ATG
- Pressure	bar	3
Rear tyres		ALLIANCE
- Size		400/80-24 A325 162A8 ATG
- Pressure	bar	3

<b>ELECTRIC CIRCUIT</b>		
Battery	STANDARD	12 V - 180 Ah - 900 A EN
	OPTION	12 V - 180 Ah - 1235 A EN
Alternator		14V - 95 A
- Type		ISKRA AAK3869
Starter		12 V - 3,2 kW
- Type		ISKRA AZE4668

<b>BRAKE SYSTEM</b>		
Service brake		Hydraulic power brake
- Type of brake		Oil-immersed multi-disc brake
- Type of control		Foot-operated for the front and rear axles
Parking brake		Mechanical
- Type of brake		Disk on gear-box output
- Type of control		Manual

<b>SOUND AND VIBRATION</b>		
Sound pressure level in the driver's cab LpA (according to standard NF EN 12053)	dB(A)	79 (cab closed); xx (cab open)
Sound pressure (according to Directive 2009/76)	dB(A)	xx (cab closed); xx (cab open)
Sound pressure level ensured in the LwA environment (according to Directive 2000/14/EC modified by Directive 2005/88/EC)	dB(A)	104 (measured); 104 (guaranteed)
Sound level in motion (according to Directive 2009/63)	dB(A)	xx
Average weighted acceleration on driver's body (according to standard NF EN 13059)	m/s <sup>2</sup>	1,1
The average weighted acceleration transmitted to the driver's hand/ arm system (according to standard ISO 5349-2)	m/s <sup>2</sup>	< 2,5
Standard seat vibration	m/s <sup>2</sup>	xx (lightweight operator); xx (heavyweight operator)



<b>HYDRAULIC CIRCUIT</b>			
Hydraulic pump		Gear pump with flow divider	
- Type		1st casing	2nd casing
- Capacity	cm <sup>3</sup>	39	21
- Max. rating capacity unladen	ℓ/min	93	50
- Flow rate at 1,600 rpm	ℓ/min	63	34
Filtration			
- Return	µm	10	
- Suction	µm	125	
Maximum service pressure		260	
- Telescoping circuit	bar	190 / 260	
- Lifting circuit	bar	260 / 260	
- Tilting circuit	bar	260 / 190	
- Attachment circuit (OPTION)	bar	260	
- Steering circuit	bar	140	

<b>HYDRAULIC MOVEMENTS</b>			
Longitudinal stability limiter and warning device		Electronic	
Lifting motions (boom retracted)			
- Unladen lifting	s - m/min	7,8 - 34,6	
- Laden lifting	s - m/min	9 - 30	
- Unladen lowering	s - m/min	6,3 - 42,9	
- Laden lowering	s - m/min	6,4 - 42,2	
Telescoping motions (boom raised)			
- Unladen extending	s - m/min	14,5 - 22,6	
- Laden extending	s - m/min	13,8 - 21,5	
- Unladen retracting	s - m/min	9,4 - 33,2	
- Laden retracting	s - m/min	7,2 - 43,3	
Tilting movements			
- Unladen digging	s - °/s	3,4 - 42,9	
- Unladen discharging	s - °/s	2,9 - 50,3	

<b>SPECIFICATIONS AND WEIGHTS</b>			
Speed of movement for lift truck in standard configuration on flat ground (except in specific conditions)			
- Front unladen	1	km/h	4,4
	2	km/h	7,4
	3	km/h	15
	4	km/h	26,4
- Rear unladen	1	km/h	4,4
	2	km/h	7,4
	3	km/h	15
	4	km/h	26,4
Standard attachment		TFF 35 MT 1040	
- Weight of attachment (without forks)	kg	165	
- Weight of forks (each)	kg	67,5	
Rated capacity with standard attachment	kg	3300	
Tipping load at maximum reach on tires	kg	450	
Distance from the centre of gravity of the load to the base of the forks	mm	500	
Standard lifting height	mm	9000	
Lift truck weight without attachment	kg	6870	
Weight of lift truck with standard attachment			
- Unladen	kg	7170	
- At rated load	kg	10470	
Weight per axle with standard attachment (transport position)			
- Front unladen	kg	3470	
- Rear unladen	kg	3700	
- Front rated load	kg	8880	
- Rear rated load	kg	1590	
Weight per axle with standard attachment (boom extended)			
- Front rated load	kg	7200	
- Rear rated load	kg	420	
Drag strain on the coupling hook			
- Unladen (sliding)	daN	5030	
- At rated load (transmission setting)	daN	7920	
Break-out force with bucket (according to standard ISO 8313)	daN	5770	



**CHARACTERISTICS** MT 1033...

<b>ENGINE</b>		
Type		DEUTZ TD3.6L/2501-2848
Fuel		Diesel
Number of cylinders		4 in line
Suction		Supercharged
Injection system		Direct
Ignition sequence		1.3.4.2
Capacity	cm3	3621
Bore and stroke	mm	98 x 120
Compression ratio		18:1
Nominal speed laden	rpm	2200
Min. rpm unladen	rpm	930
Max. rpm unladen	rpm	2360
Power ISO/TR 14396	hp - kW	75 - 55,4
Power SAE J 1995	hp - kW	75 - 55,4
Maximum torque ISO/TR 14396	Nm	340 at 1,600 rpm
Air filtration efficiency	%	99,9
Type of cooling		By water
Fan		Puller

<b>TRANSMISSION</b>		
Gearbox		TURNER
- Type		Mechanical
- Reversing shift		Electro-hydraulic
- Torque converter		SACHS
- Number of forward speeds		4
- Number of reverse speeds		4
Angle gear box		TURNER
Front axle		DANA
- Differential		Limited slip
Rear axle		DANA
- Differential		Without locking
Drive wheels		Permanent 4 WD
- 2/4 wheel drive control		No
Front tyres		ALLIANCE
- Size		400/80-24 A325 162A8 ATG
- Pressure	bar	3
Rear tyres		ALLIANCE
- Size		400/80-24 A325 162A8 ATG
- Pressure	bar	3

<b>ELECTRIC CIRCUIT</b>		
Battery	STANDARD	12 V - 180 Ah - 900 A EN
	OPTION	12 V - 180 Ah - 1235 A EN
Alternator		14V - 95 A
- Type		ISKRA AAK3869
Starter		12 V - 3,2 kW
- Type		ISKRA AZE4668

<b>BRAKE SYSTEM</b>		
Service brake		Hydraulic power brake
- Type of brake		Oil-immersed multi-disc brake
- Type of control		Foot-operated for the front and rear axles
Parking brake		Mechanical
- Type of brake		Disk on gear-box output
- Type of control		Manual

<b>SOUND AND VIBRATION</b>		
Sound pressure level in the driver's cab LpA (according to standard NF EN 12053)	dB(A)	79 (cab closed); xx (cab open)
Sound pressure (according to Directive 2009/76)	dB(A)	xx (cab closed); xx (cab open)
Sound pressure level ensured in the LwA environment (according to Directive 2000/14/EC modified by Directive 2005/88/EC)	dB(A)	104 (measured); 104 (guaranteed)
Sound level in motion (according to Directive 2009/63)	dB(A)	xx
Average weighted acceleration on driver's body (according to standard NF EN 13059)	m/s <sup>2</sup>	1,1
The average weighted acceleration transmitted to the driver's hand/ arm system (according to standard ISO 5349-2)	m/s <sup>2</sup>	< 2,5
Standard seat vibration	m/s <sup>2</sup>	xx (lightweight operator); xx (heavyweight operator)



HYDRAULIC CIRCUIT			
Hydraulic pump		Gear pump with flow divider	
- Type		1st casing	
- Capacity	cm <sup>3</sup>	39	21
- Max. rating capacity unladen	ℓ/min	93	50
- Flow rate at 1,600 rpm	ℓ/min	63	34
Filtration			
- Return	µm	10	
- Suction	µm	125	
Maximum service pressure		260	
- Telescoping circuit	bar	190 / 260	
- Lifting circuit	bar	260 / 260	
- Tilting circuit	bar	260 / 190	
- Stabiliser system	bar	260	
- Attachment circuit (OPTION)	bar	260	
- Steering circuit	bar	140	

HYDRAULIC MOVEMENTS			
Longitudinal stability limiter and warning device		Electronic	
Lifting motions (boom retracted)			
- Unladen lifting	s - m/min	8,55 - 33,3	
- Laden lifting	s - m/min	8,89 - 32,1	
- Unladen lowering	s - m/min	6,52 - 43,7	
- Laden lowering	s - m/min	7,23 - 39,4	
Telescoping motions (boom raised)			
- Unladen extending	s - m/min	16,2 - 10,4	
- Laden extending	s - m/min	16,5 - 10,6	
- Unladen retracting	s - m/min	9,2 - 18,6	
- Laden retracting	s - m/min	9,67 - 19,7	
Tilting movements			
- Unladen digging	s - °/s	3,44 - 36,3	
- Unladen discharging	s - °/s	2,83 - 44,2	

SPECIFICATIONS AND WEIGHTS			
Speed of movement for lift truck in standard configuration on flat ground (except in specific conditions)			
- Front unladen	1	km/h	4,8
	2	km/h	7,5
	3	km/h	15,3
	4	km/h	25,7
- Rear unladen	1	km/h	4,8
	2	km/h	7,5
	3	km/h	15,3
	4	km/h	25,7
Standard attachment		TFF 35 MT 1040	
- Weight of attachment (without forks)	kg	165	
- Weight of forks (each)	kg	67,5	
Rated capacity with standard attachment	kg	3300	
Tipping load at maximum reach on stabilisers	kg	1000	
Tipping load at maximum reach on tires	kg	250	
Distance from the centre of gravity of the load to the base of the forks	mm	500	
Standard lifting height	mm	9640	
Lift truck weight without attachment	kg	7500	
Weight of lift truck with standard attachment			
- Unladen	kg	7800	
- At rated load	kg	11100	
Weight per axle with standard attachment (transport position)			
- Front unladen	kg	4180	
- Rear unladen	kg	3620	
- Front rated load	kg	10040	
- Rear rated load	kg	1060	
Weight per axle with standard attachment (boom extended)			
- Front rated load	kg	7710	
- Rear rated load	kg	340	
Drag strain on the coupling hook			
- Unladen (sliding)	daN	5760	
- At rated load (transmission setting)	daN	8580	
Break-out force with bucket (according to standard ISO 8313)	daN	5330	



**TYRES**

MT 733...		PRESSURE (bar)	LOAD PER TYRE (kg)			
			FRONT UNLADEN	FRONT LADEN	REAR UNLADEN	REAR LADEN
ALLIANCE	400/80-24 A325 162A8 ATG	3	1650	4350	1700	650
MICHELIN	400/80-24 162A8 IND TL PCL	3				
	15,5R25 XHA TUBELESS	3,5				
	460/70 R24 159A8/159B IND TL BIBLOAD HARD SURFACE	3,4				

		PRESSURE (bar)	LOAD (kg)	GROUND CONTACT PRESSURE (kg/cm <sup>2</sup> )		GROUND CONTACT AREA (cm <sup>2</sup> )	
				HARD GROUND	SOFT GROUND	HARD GROUND	SOFT GROUND
ALLIANCE	400/80-24 A325 162A8 ATG	3	650				
			1650				
			1700				
			4350				
MICHELIN	400/80-24 162A8 IND TL PCL	3	650	2,08	0,56	328	1222
			1650	2,48	1,05	664	1571
			1700	2,50	1,07	680	1589
			4350	3,04	1,71	1423	2516
	15,5R25 XHA TUBELESS	3,5	650	4,03	2,27	169	297
			1650	4,81	2,54	343	650
			1700	4,84	2,55	351	667
			4350	5,59	2,89	774	1497
460/70 R24 159A8/159B IND TL BIBLOAD HARD SURFACE	3,4	650					
		1650					
		1700					
		4350					

MT 933...		PRESSURE (bar)	LOAD PER TYRE (kg)			
			FRONT UNLADEN	FRONT LADEN	REAR UNLADEN	REAR LADEN
ALLIANCE	400/80-24 A325 162A8 ATG	3	1750	4450	1850	800
MICHELIN	400/80-24 162A8 IND TL PCL	3				
	15,5R25 XHA TUBELESS	3,5				
	460/70 R24 159A8/159B IND TL BIBLOAD HARD SURFACE	3,4				

		PRESSURE (bar)	LOAD (kg)	GROUND CONTACT PRESSURE (kg/cm <sup>2</sup> )		GROUND CONTACT AREA (cm <sup>2</sup> )	
				HARD GROUND	SOFT GROUND	HARD GROUND	SOFT GROUND
ALLIANCE	400/80-24 A325 162A8 ATG	3	800				
			1750				
			1850				
			4450				
MICHELIN	400/80-24 162A8 IND TL PCL	3	800	2,14	0,64	378	1274
			1750	2,51	1,09	696	1606
			1850	2,54	1,12	726	1641
			4450	3,06	1,73	1450	2551
	15,5R25 XHA TUBELESS	3,5	800	4,15	2,31	195	350
			1750	4,86	2,55	360	685
			1850	4,90	2,57	377	719
			4450	5,62	2,91	789	1527
	460/70 R24 159A8/159B IND TL BIBLOAD HARD SURFACE	3,4	800				
			1750				
			1850				
			4450				



MT 1033...		PRESSURE (bar)	LOAD PER TYRE (kg)			
			FRONT UNLADEN	FRONT LADEN	REAR UNLADEN	REAR LADEN
ALLIANCE	400/80-24 A325 162A8 ATG	3	2100	5000	1800	550
MICHELIN	400/80-24 162A8 IND TL PCL	3				
	15,5R25 XHA TUBELESS	3,5				
	460/70 R24 159A8/159B IND TL BIBLOAD HARD SURFACE	3,4				

		PRESSURE (bar)	LOAD (kg)	GROUND CONTACT PRESSURE (kg/cm <sup>2</sup> )		GROUND CONTACT AREA (cm <sup>2</sup> )	
				HARD GROUND	SOFT GROUND	HARD GROUND	SOFT GROUND
ALLIANCE	400/80-24 A325 162A8 ATG	3	550				
			1800				
			2100				
			5000				
MICHELIN	400/80-24 162A8 IND TL PCL	3	550	2,04	0,52	294	1187
			1800	2,53	1,10	711	1624
			2100	2,61	1,21	803	1729
			5000	3,16	1,85	1600	2743
	15,5R25 XHA TUBELESS	3,5	550	3,95	2,24	152	261
			1800	4,88	2,56	368	702
			2100	5,00	2,60	419	806
			5000	5,76	2,98	876	1695
	460/70 R24 159A8/159B IND TL BIBLOAD HARD SURFACE	3,4	550				
			1800				
			2100				
			5000				

**DIMENSIONS AND LOAD CHARTS** MT 733...

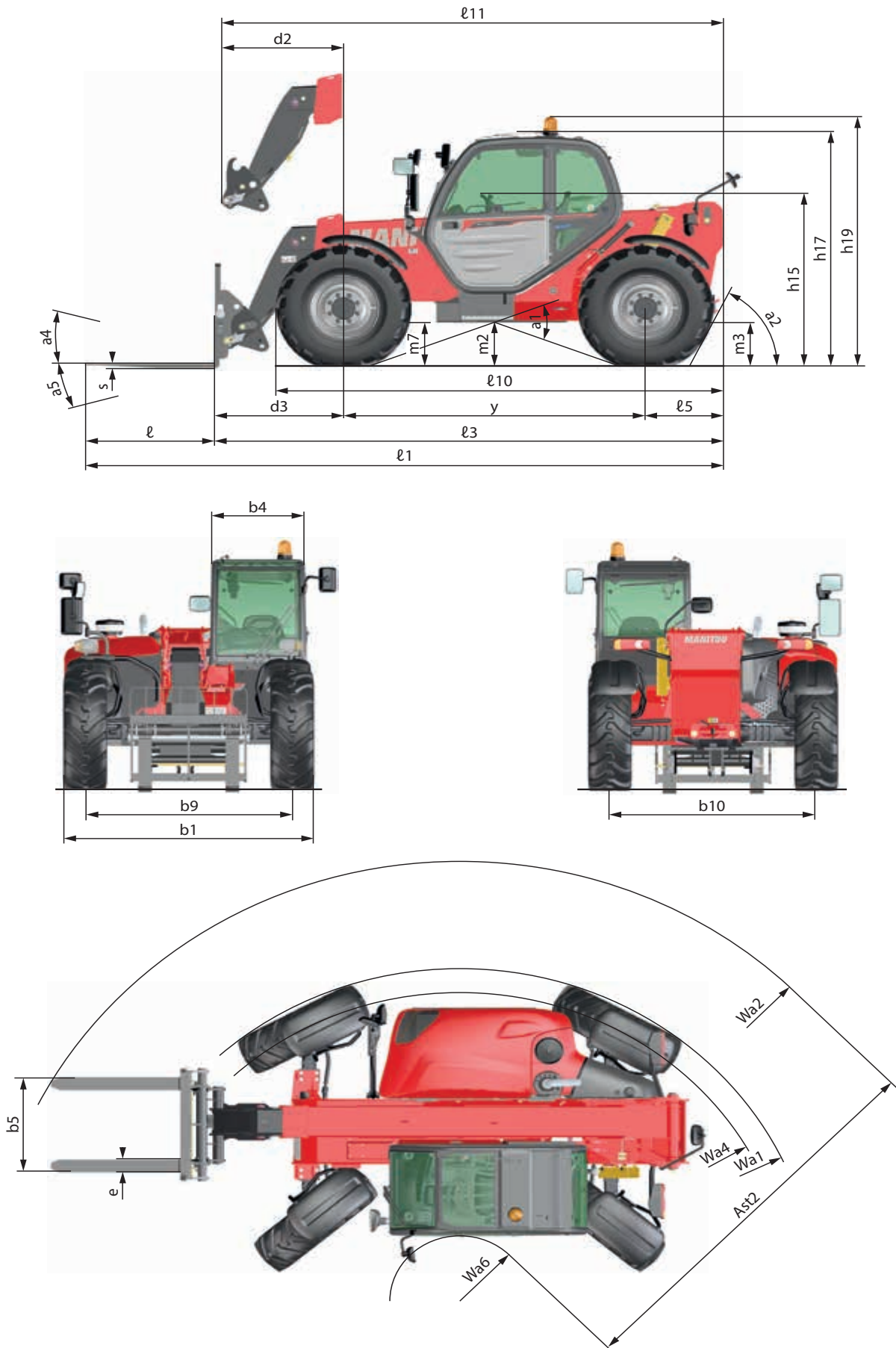



MACHINE LENGTH	<b>ℓ1</b>	mm	5929
	<b>ℓ3</b>	mm	4729
	<b>ℓ5</b>	mm	725
	<b>ℓ10</b>	mm	4160
	<b>ℓ11</b>	mm	4673
MACHINE WIDTH	<b>b1</b>	mm	2334
	<b>b4</b>	mm	890
	<b>b5</b>	mm	1040
	<b>b9</b>	mm	1930
	<b>b10</b>	mm	1930
MACHINE HEIGHT	<b>h15</b>	mm	1717
	<b>h17</b>	mm	2300
	<b>h19</b>	mm	2500
	<b>d2</b>	mm	1138
DISTANCE	<b>d3</b>	mm	1194
AISLE WIDTH	<b>Ast2</b>	mm	3490
ATTACHMENT	<b>ℓ</b>	mm	1200
	<b>s</b>	mm	45
	<b>e</b>	mm	125
TURNING RADIUS	<b>Wa1</b>	mm	3800
	<b>Wa2</b>	mm	4800
	<b>Wa4</b>	mm	3598
	<b>Wa6</b>	mm	1310
GROUND CLEARANCE	<b>m2</b>	mm	435
	<b>m3</b>	mm	435
	<b>m7</b>	mm	435
ANGLE	<b>a1</b>	°	38
	<b>a2</b>	°	64
	<b>a4</b>	°	12
	<b>a5</b>	°	114
	WHEELBASE	<b>y</b>	mm

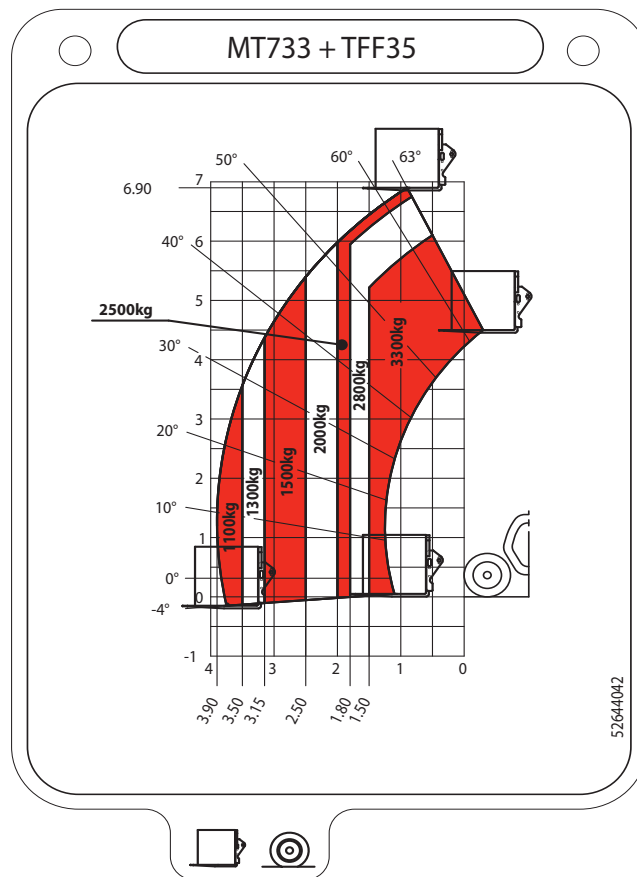

**DIMENSIONS AND LOAD CHARTS** MT 933...

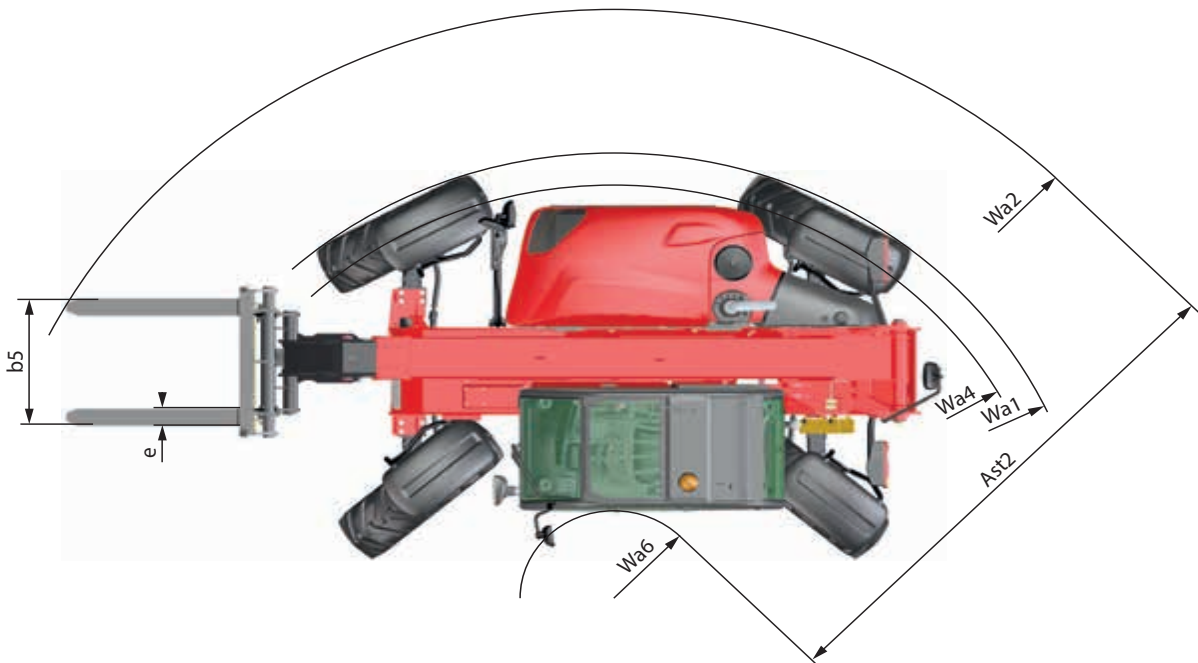
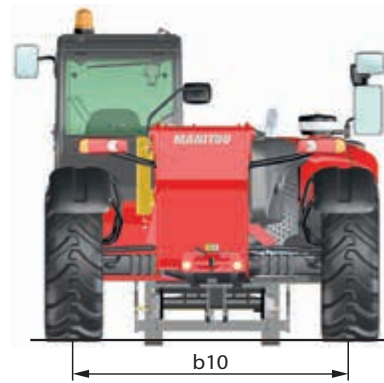
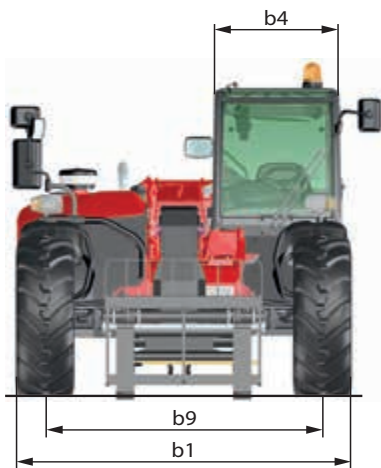
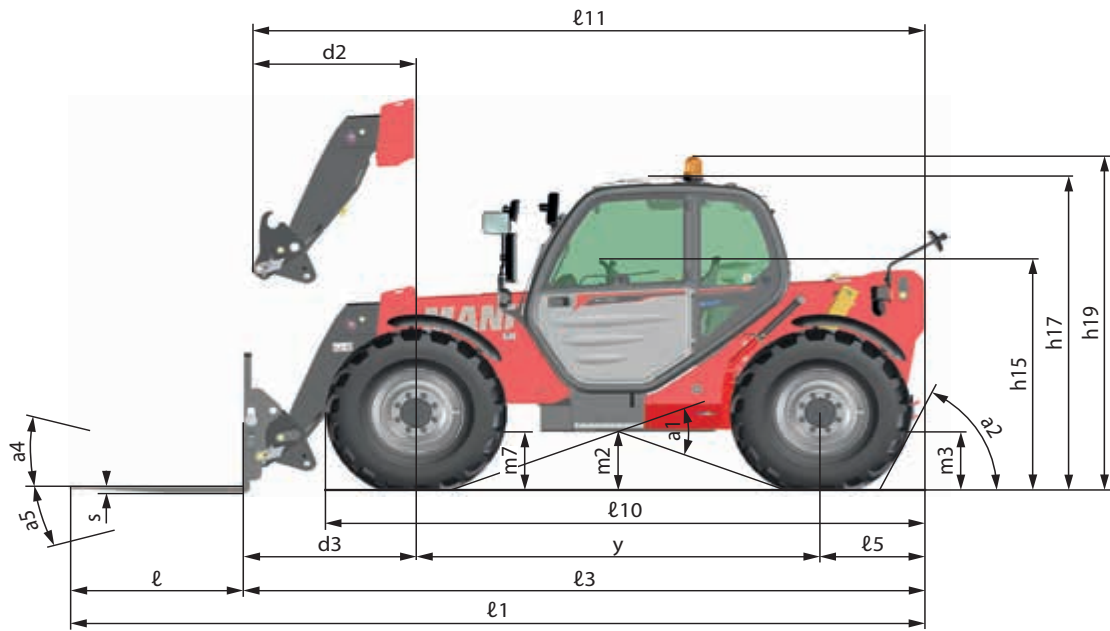



MACHINE LENGTH	<b>ℓ1</b>	mm	5878
	<b>ℓ3</b>	mm	4678
	<b>ℓ5</b>	mm	725
	<b>ℓ10</b>	mm	4160
	<b>ℓ11</b>	mm	4608
MACHINE WIDTH	<b>b1</b>	mm	2334
	<b>b4</b>	mm	890
	<b>b5</b>	mm	1040
	<b>b9</b>	mm	1930
	<b>b10</b>	mm	1930
MACHINE HEIGHT	<b>h15</b>	mm	1717
	<b>h17</b>	mm	2300
	<b>h19</b>	mm	2500
DISTANCE	<b>d2</b>	mm	1073
AISLE WIDTH	<b>d3</b>	mm	1143
	<b>Ast2</b>	mm	3460
ATTACHMENT	<b>ℓ</b>	mm	1200
	<b>s</b>	mm	45
	<b>e</b>	mm	125
TURNING RADIUS	<b>Wa1</b>	mm	3800
	<b>Wa2</b>	mm	4770
	<b>Wa4</b>	mm	3598
GROUND CLEARANCE	<b>Wa6</b>	mm	1310
	<b>m2</b>	mm	435
	<b>m3</b>	mm	435
ANGLE	<b>m7</b>	mm	435
	<b>a1</b>	°	38
	<b>a2</b>	°	64
	<b>a4</b>	°	12
WHEELBASE	<b>a5</b>	°	114
	<b>y</b>	mm	2810

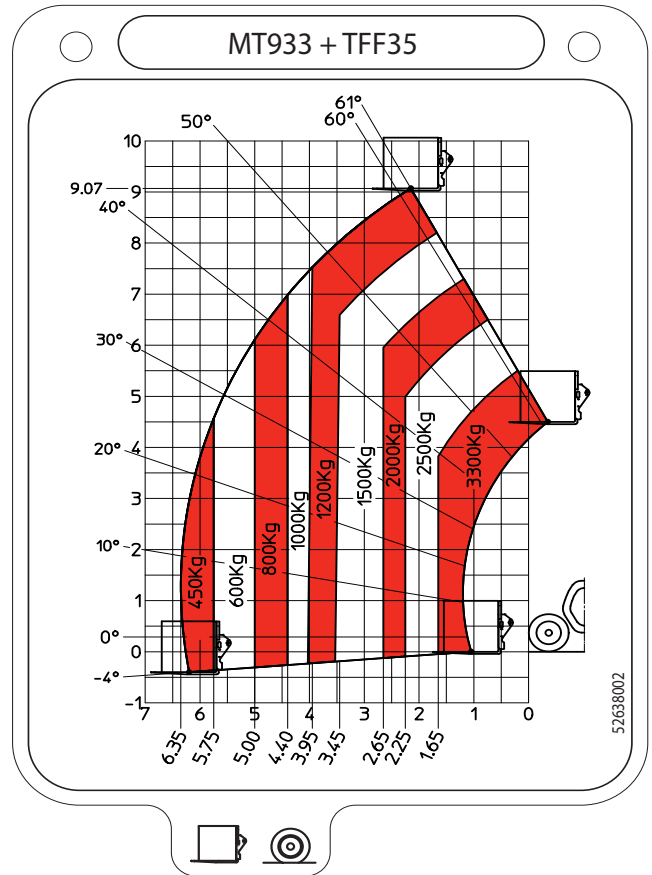





MACHINE LENGTH	<b>ℓ1</b>	mm	6128
	<b>ℓ3</b>	mm	4928
	<b>ℓ5</b>	mm	725
	<b>ℓ10</b>	mm	4040
	<b>ℓ11</b>	mm	5017
MACHINE WIDTH	<b>b1</b>	mm	2334
	<b>b4</b>	mm	890
	<b>b5</b>	mm	1040
	<b>b7</b>	mm	2210
	<b>b9</b>	mm	1930
MACHINE HEIGHT	<b>h15</b>	mm	1717
	<b>h17</b>	mm	2300
	<b>h19</b>	mm	2500
DISTANCE	<b>d1</b>	mm	1130
	<b>d2</b>	mm	1602
	<b>d3</b>	mm	1513
AISLE WIDTH	<b>Ast2</b>	mm	3720
ATTACHMENT	<b>ℓ</b>	mm	1200
	<b>s</b>	mm	45
	<b>e</b>	mm	125
TURNING RADIUS	<b>Wa1</b>	mm	3702
	<b>Wa2</b>	mm	4950
	<b>Wa4</b>	mm	3500
	<b>Wa6</b>	mm	1230
GROUND CLEARANCE	<b>m2</b>	mm	435
	<b>m3</b>	mm	435
	<b>m5</b>	mm	135
	<b>m7</b>	mm	435
ANGLE	<b>a1</b>	°	40
	<b>a2</b>	°	64
	<b>a4</b>	°	12
	<b>a5</b>	°	114
WHEELBASE	<b>y</b>	mm	2690

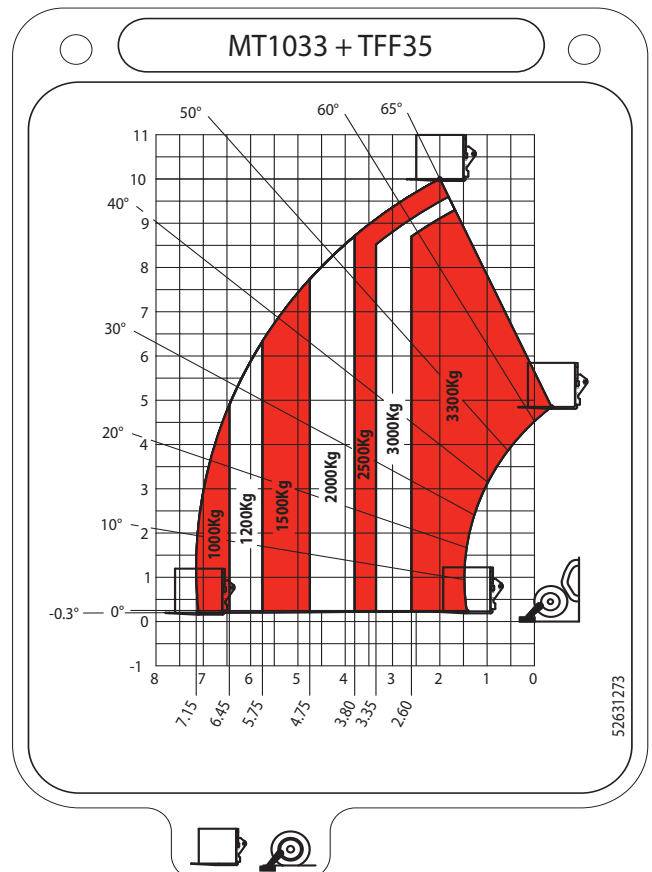
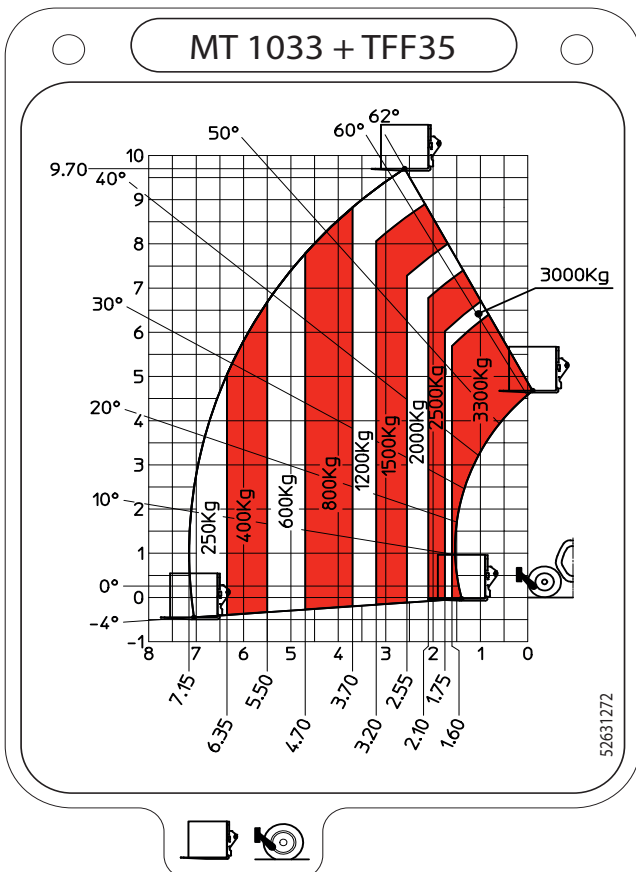

**VISIBILITY** MT 733...

We use European standard EN15830 relating to operator visibility.

- Adhere to the instructions for optimising operator visibility in the immediate vicinity (<math>\leq 1</math> - OPERATING AND SAFETY INSTRUCTIONS: INSTRUCTIONS TO THE OPERATOR: DRIVING INSTRUCTIONS UNLADEN AND LADEN: D - VISIBILITY).

**DESCRIPTION AND ADJUSTMENT OF REAR-VIEW MIRRORS**

- 1 - LEFT REAR-VIEW MIRROR
- 2 - MAIN RIGHT REAR-VIEW MIRROR
- 3 - SECONDARY RIGHT REAR-VIEW MIRROR
- 4 - RIGHT SIDE REAR-VIEW MIRROR
- 5 - INSIDE REAR-VIEW MIRROR (OPTION)
- 6 - REAR-VIEW MIRROR

- Place the lift truck on level ground with the engine stopped, and the boom retracted and lowered as far as possible.
- Note the position of the reference points ●...○ in the illustrations, to see and correctly adjust the rear-view mirrors.

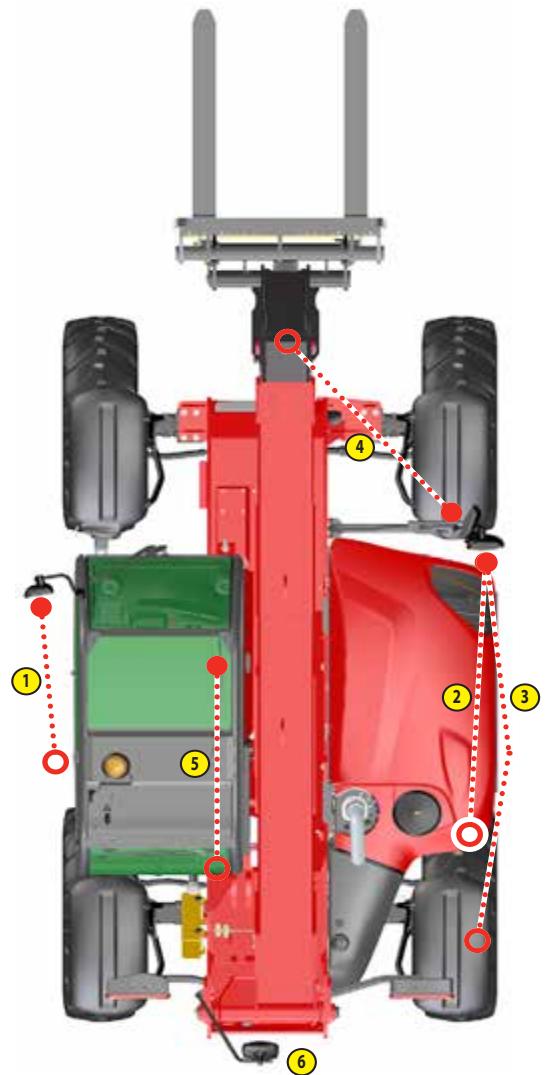
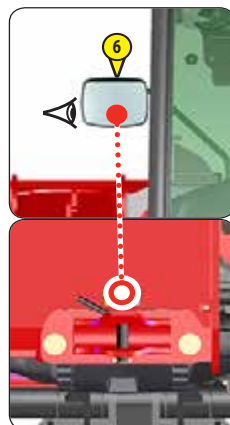
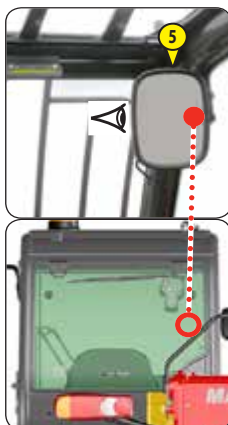
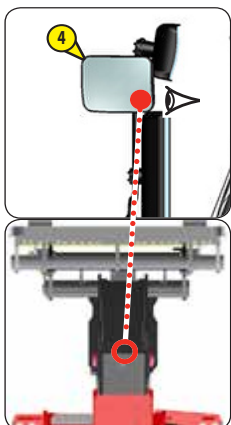
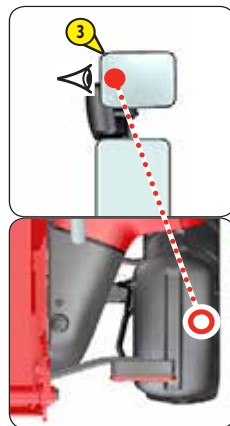
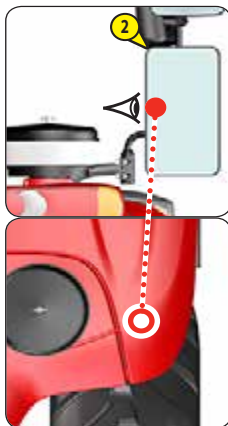
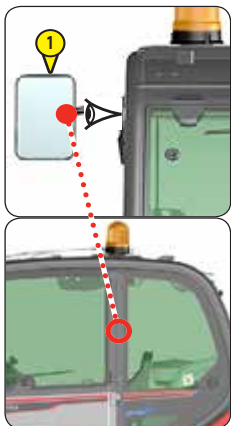

**DIRECT AND/OR INDIRECT VISIBILITY BLIND SPOT ZONES**

The two diagrams below indicate blind spot zones on the visibility test circle (12 m radius) and the 1 m rectangular zone around the lift truck, according to tests carried out in accordance with standard EN 15830.

**HANDLING SUSPENDED LOADS** (Test carried out in accordance with 6.3.3 of standard EN 15830)

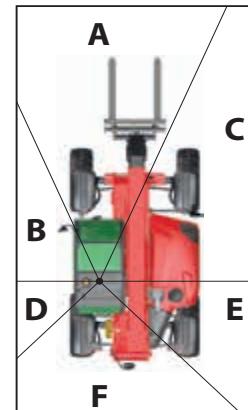
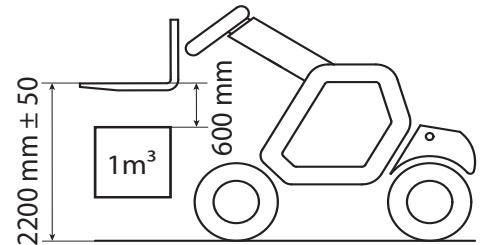
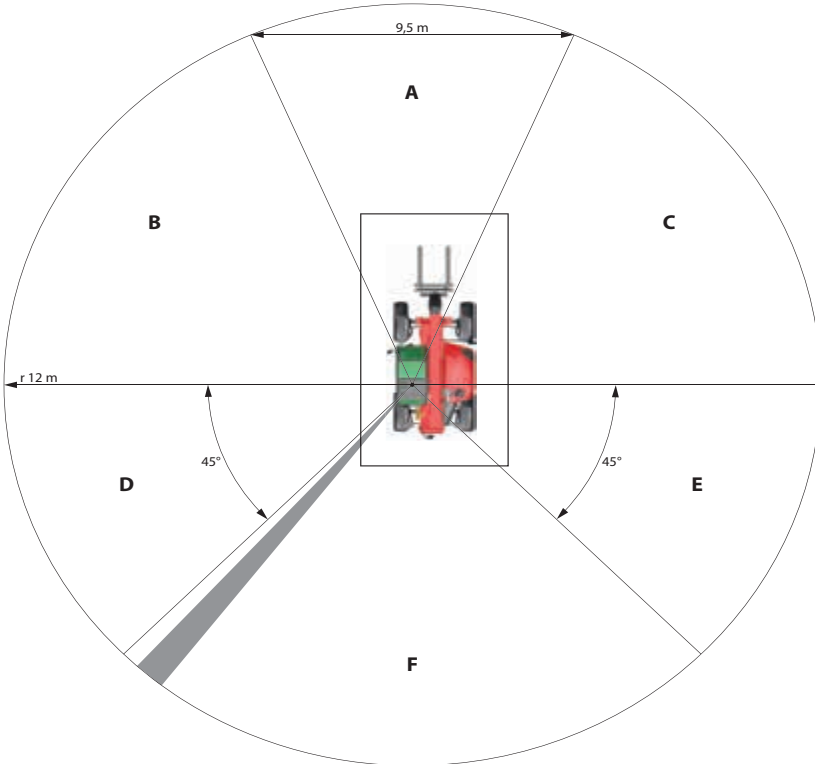

**LOADING THE TRAILER** (Test carried out in accordance with 6.3.4 of standard EN 15830)

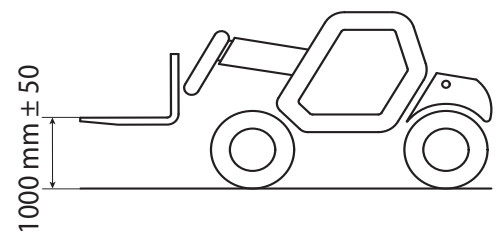
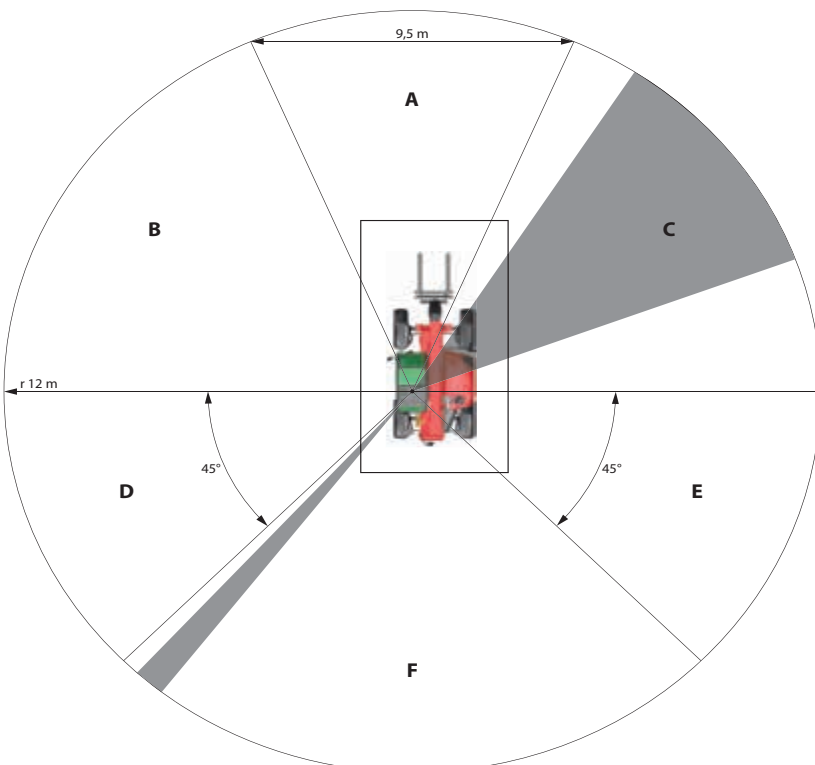

**VISIBILITY** MT 933...

We use European standard EN15830 relating to operator visibility.

- Adhere to the instructions for optimising operator visibility in the immediate vicinity (<math>\leq 1</math> - OPERATING AND SAFETY INSTRUCTIONS: INSTRUCTIONS TO THE OPERATOR: DRIVING INSTRUCTIONS UNLADEN AND LADEN: D - VISIBILITY).

**DESCRIPTION AND ADJUSTMENT OF REAR-VIEW MIRRORS**

- 1 - LEFT REAR-VIEW MIRROR
- 2 - MAIN RIGHT REAR-VIEW MIRROR
- 3 - SECONDARY RIGHT REAR-VIEW MIRROR
- 4 - RIGHT SIDE REAR-VIEW MIRROR
- 5 - INSIDE REAR-VIEW MIRROR (OPTION)
- 6 - REAR-VIEW MIRROR

- Place the lift truck on level ground with the engine stopped, and the boom retracted and lowered as far as possible.
- Note the position of the reference points ●...○ in the illustrations, to see and correctly adjust the rear-view mirrors.

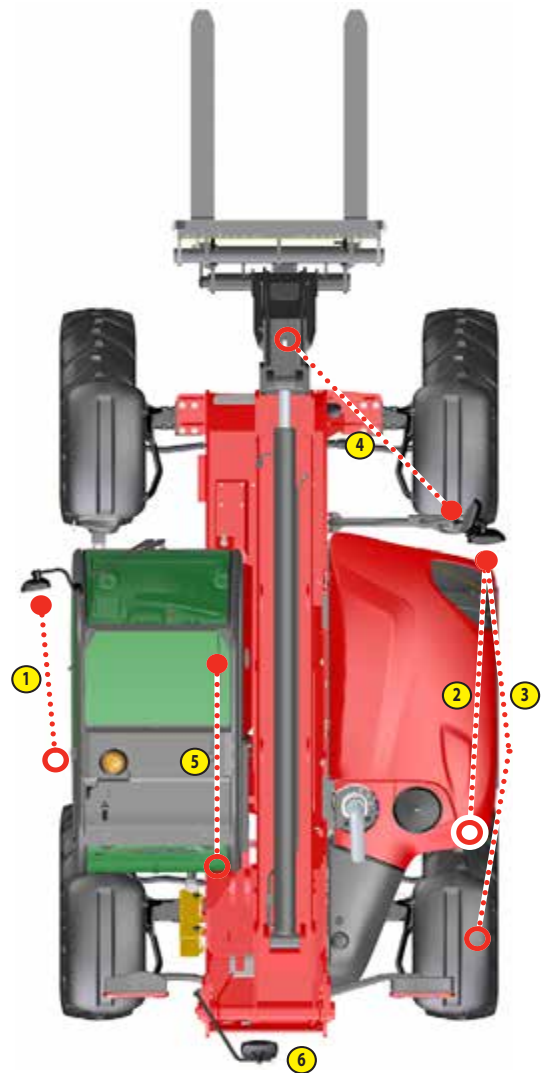
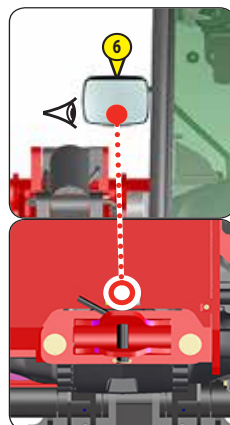
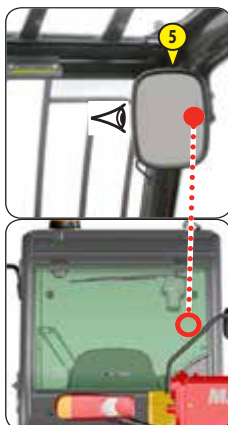
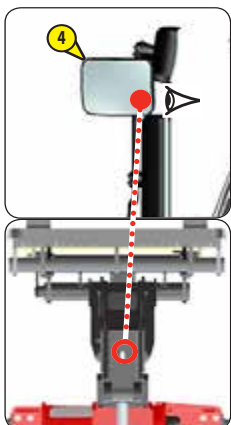
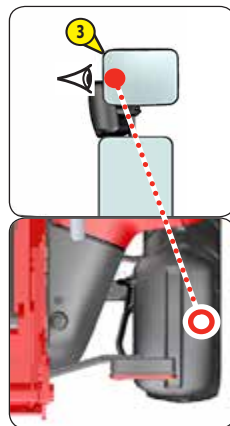
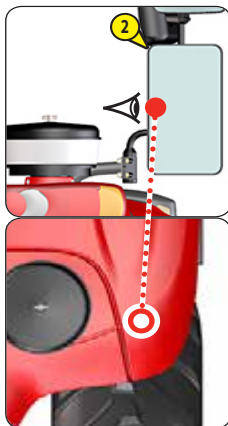
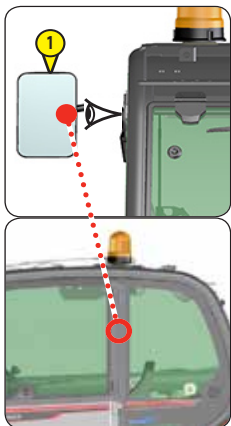

**DIRECT AND/OR INDIRECT VISIBILITY BLIND SPOT ZONES**

The two diagrams below indicate blind spot zones on the visibility test circle (12 m radius) and the 1 m rectangular zone around the lift truck, according to tests carried out in accordance with standard EN 15830.

**HANDLING SUSPENDED LOADS** (Test carried out in accordance with 6.3.3 of standard EN 15830)

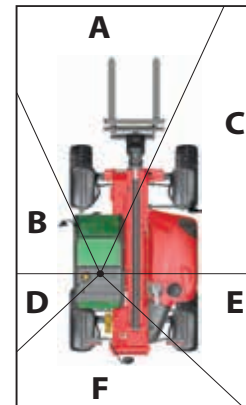
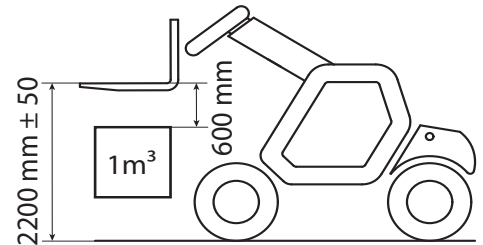
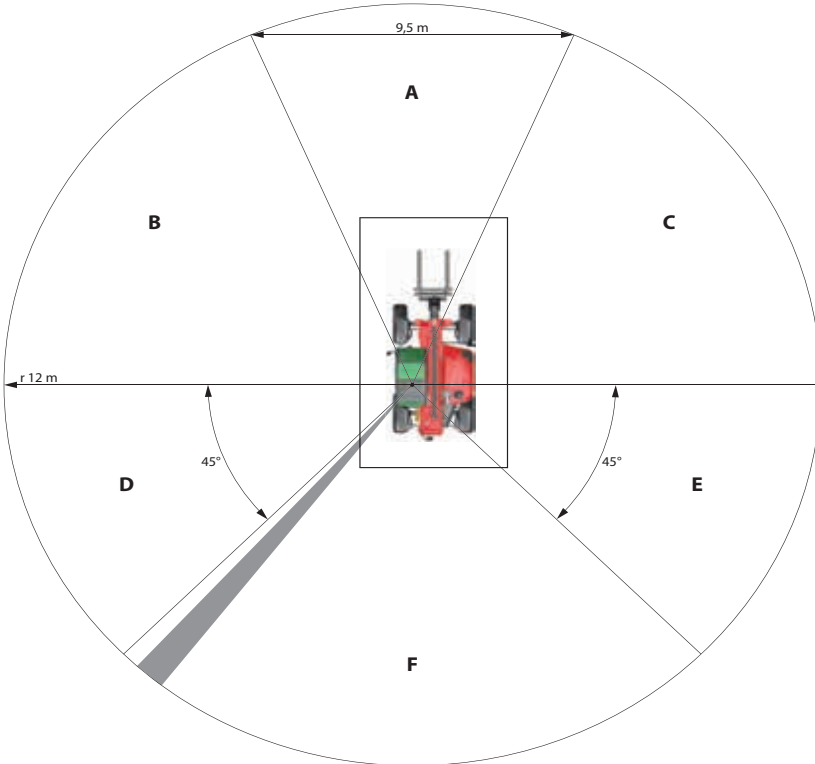

**LOADING THE TRAILER** (Test carried out in accordance with 6.3.4 of standard EN 15830)

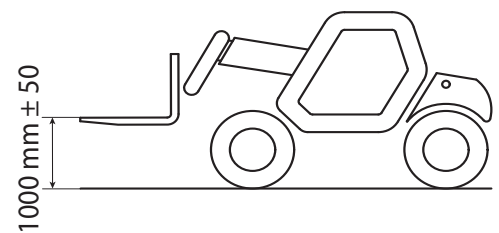
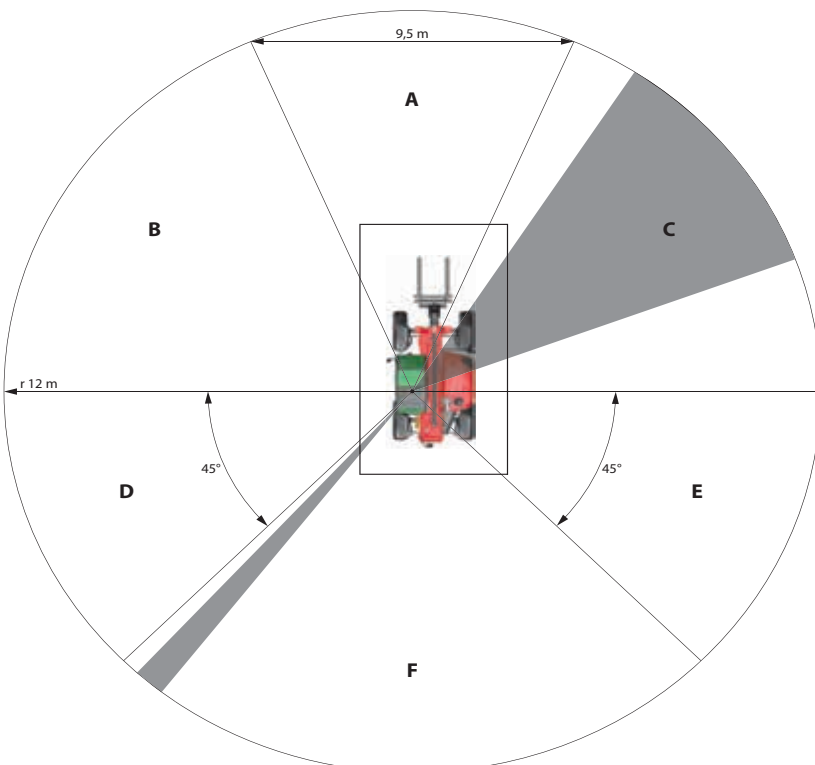

**VISIBILITY** MT 1033...

We use European standard EN15830 relating to operator visibility.

- Adhere to the instructions for optimising operator visibility in the immediate vicinity (<math>\leq 1</math> - OPERATING AND SAFETY INSTRUCTIONS: INSTRUCTIONS TO THE OPERATOR: DRIVING INSTRUCTIONS UNLADEN AND LADEN: D - VISIBILITY).

**DESCRIPTION AND ADJUSTMENT OF REAR-VIEW MIRRORS**

- 1 - LEFT REAR-VIEW MIRROR
- 2 - MAIN RIGHT REAR-VIEW MIRROR
- 3 - SECONDARY RIGHT REAR-VIEW MIRROR
- 4 - RIGHT SIDE REAR-VIEW MIRROR
- 5 - INSIDE REAR-VIEW MIRROR (OPTION)
- 6 - REAR-VIEW MIRROR

- Place the lift truck on level ground with the engine stopped, and the boom retracted and lowered as far as possible.
- Note the position of the reference points ●...○ in the illustrations, to see and correctly adjust the rear-view mirrors.

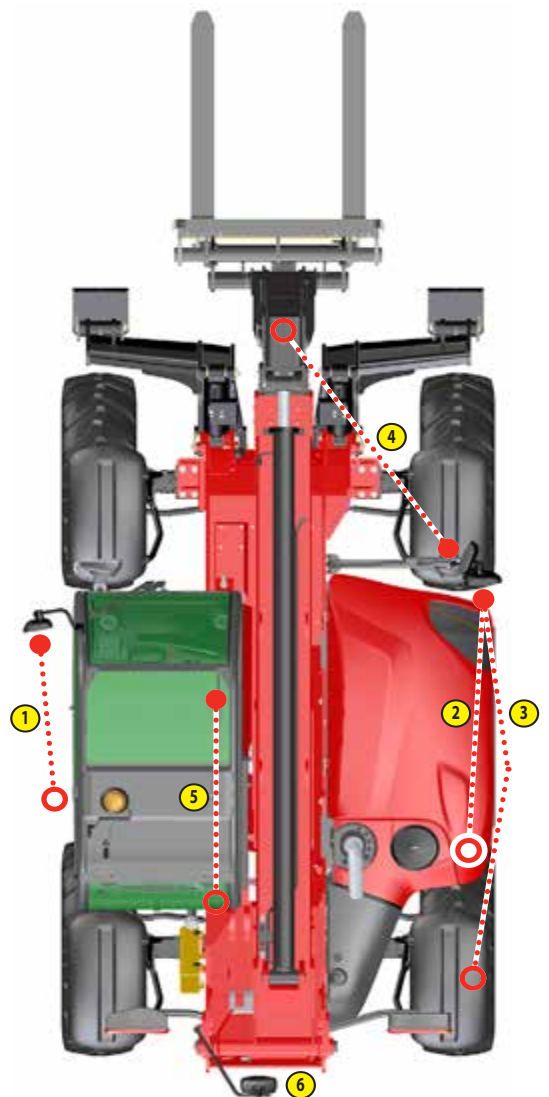
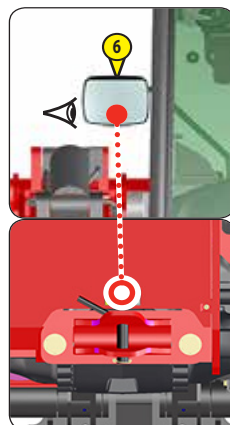
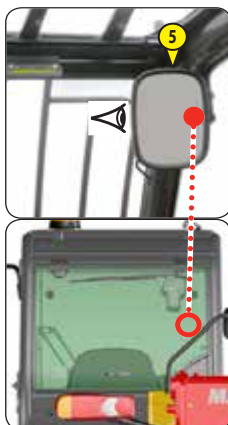
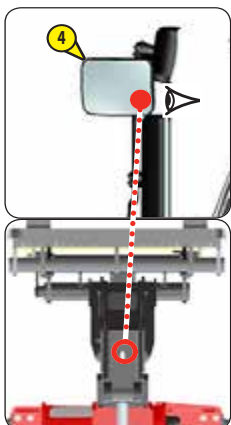
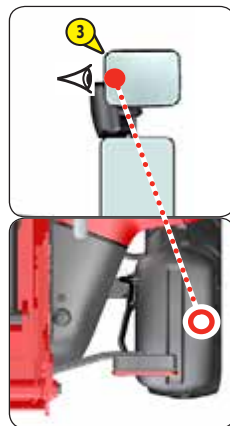
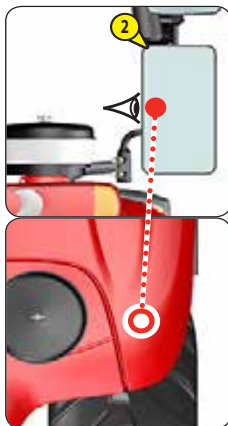
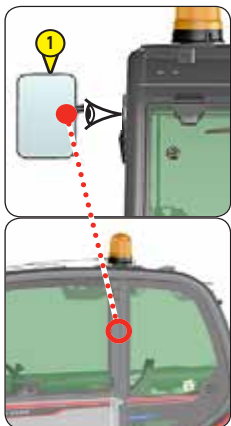

**DIRECT AND/OR INDIRECT VISIBILITY BLIND SPOT ZONES**

The two diagrams below indicate blind spot zones on the visibility test circle (12 m radius) and the 1 m rectangular zone around the lift truck, according to tests carried out in accordance with standard EN 15830.

**HANDLING SUSPENDED LOADS** (Test carried out in accordance with 6.3.3 of standard EN 15830)

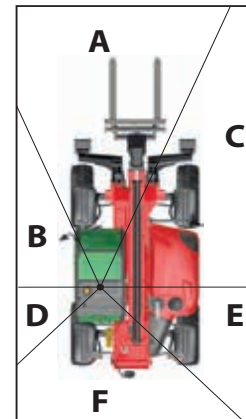
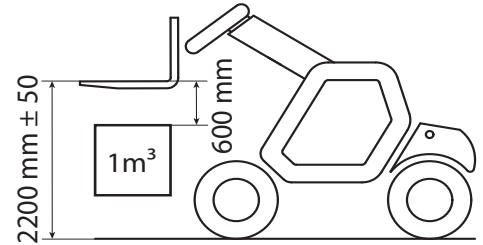
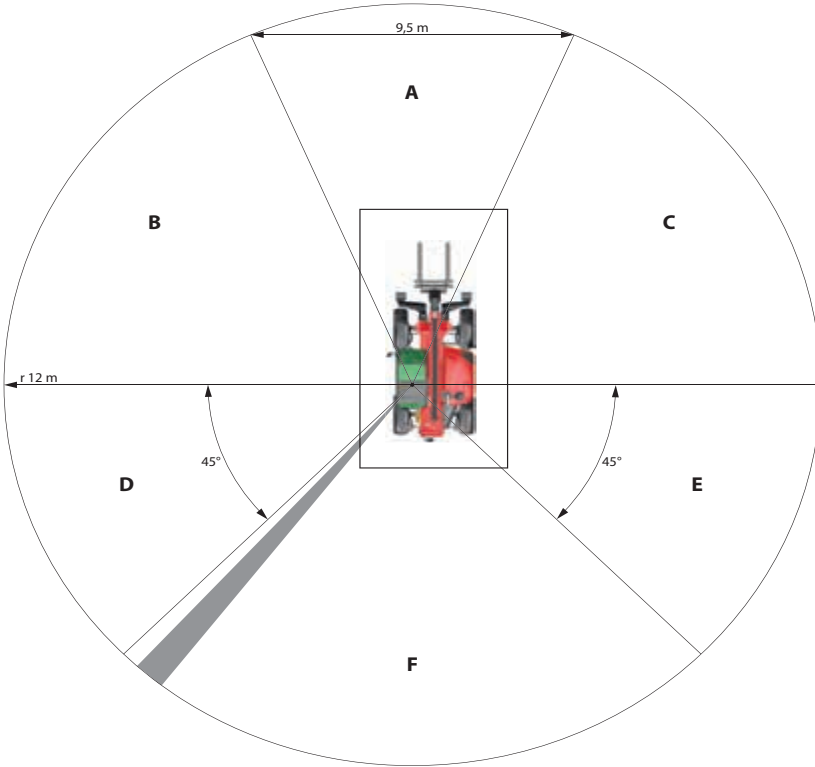

**LOADING THE TRAILER** (Test carried out in accordance with 6.3.4 of standard EN 15830)

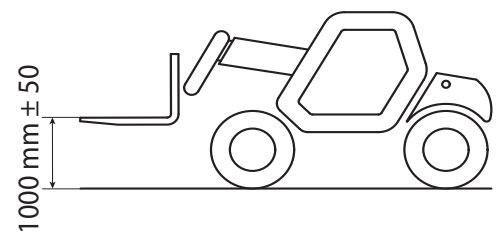
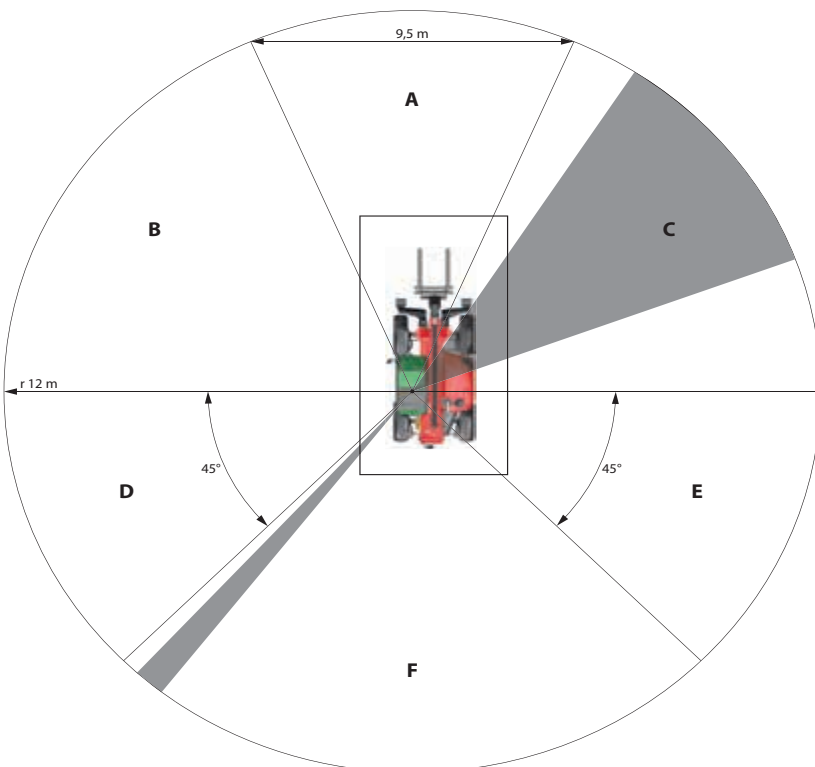



## INSTRUMENTS AND CONTROLS

### DESCRIPTION

NOTE: All the terms such as: RIGHT, LEFT, FRONT, REAR are as seen by an observer occupying the driver's seat and looking straight ahead.

1 - DRIVER'S CAB ACCESS .....	2-36
2 - DRIVER'S SEAT .....	2-36
3 - SEAT BELT .....	2-37
4 - IGNITION SWITCH .....	2-37
5 - EMERGENCY STOP .....	2-38
6 - CONTROL AND SIGNAL LIGHTS PANEL .....	2-38
7 - LONGITUDINAL STABILITY LIMITER AND WARNING DEVICE .....	2-42
8 - SWITCHES .....	2-44
9 - LIGHTING, HORN AND INDICATOR SWITCH .....	2-46
10 - FRONT AND REAR WINDSCREEN WIPER SWITCH .....	2-46
11 - STEERING SELECTION .....	2-46
12 - FUSES AND RELAYS IN THE CAB .....	2-47
13 - FUSES AND RELAYS UNDER THE ENGINE COVER .....	2-48
14 - DIAGNOSTIC PLUG .....	2-49
15 - ACCELERATOR PEDAL .....	2-49
16 - SERVICE BRAKE PEDAL AND TRANSMISSION CUT-OFF .....	2-49
17 - GEAR LEVER AND TRANSMISSION CUT-OFF .....	2-49
18 - PARKING BRAKE LEVER .....	2-49
19 - FORWARD/NEUTRAL/REVERSE GEAR SELECTION .....	2-50
20 - HYDRAULIC CONTROLS .....	2-50
21 - FUNCTION FILES .....	2-51
22 - LEVEL INDICATOR .....	2-51
23 - HEATER CONTROL .....	2-52
24 - AIR CONDITIONING CONTROLS (AIR CONDITIONING OPTION) .....	2-52
25 - WINDSCREEN DEMISTER VENTS .....	2-52
26 - HEATING VENTS .....	2-52
27 - STEERING WHEEL ADJUSTMENT LEVER (OPTION) .....	2-53
28 - DOOR OPENING HANDLE .....	2-53
29 - LOCKING HANDLE FOR UPPER HALF-DOOR .....	2-53
30 - UNLOCKING BUTTON FOR UPPER HALF-DOOR .....	2-53
31 - HANDLE FOR REAR WINDOW OPENING .....	2-53
32 - STORAGE COMPARTMENT .....	2-53
33 - STORAGE NET .....	2-53
34 - SUN VISOR (OPTION) .....	2-54
35 - ROOF LIGHT .....	2-54
36 - HOOK .....	2-54
37 - INSIDE REAR-VIEW MIRROR (OPTION) .....	2-54
38 - ARMREST .....	2-54
39 - 12V SOCKET .....	2-54
40 - BATTERY CUT-OFF .....	2-55
41 - FRONT HEADLIGHTS .....	2-55
42 - REAR LIGHTS .....	2-55
43 - ROTATING BEACON LIGHT .....	2-55
44 - BOOM SAFETY WEDGE .....	2-56
45 - FUEL TANK .....	2-56

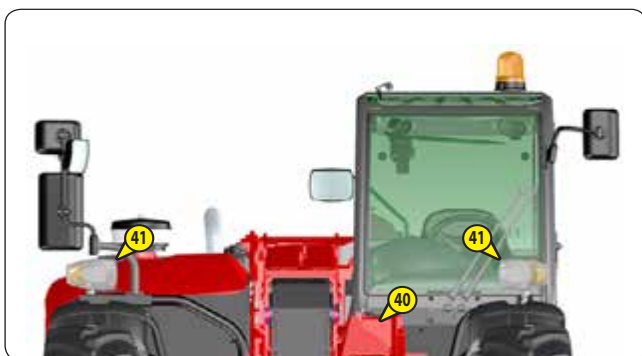
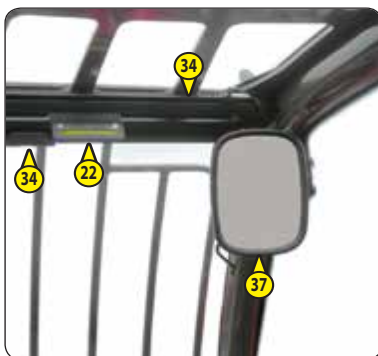
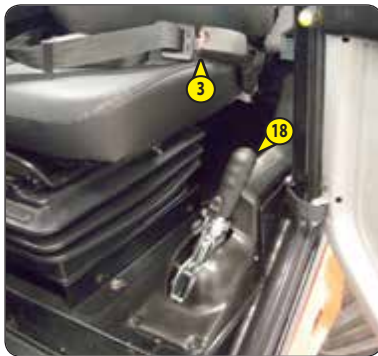



## 1 - DRIVER'S CAB ACCESS

- Face the driver's cab access to get in and out, and always use the three support points provided for this purpose.
  - 1 - Left handle.
  - 2 - Right handle.
  - 3 - Step.



## 2 - DRIVER'S SEAT

### DRIVER'S SEAT (STANDARD)

DESIGNED FOR MAXIMUM COMFORT, THIS SEAT CAN BE ADJUSTED AS FOLLOWS.

#### LONGITUDINAL ADJUSTMENT

- Unlock the locking lever 1.
- Slide the seat to the desired position.
- Release the lever and be sure it returns to the lock position.

#### SEAT HEIGHT ADJUSTMENT

- Sit down correctly in the seat.
- Turn the knob 2 according to the desired height, clockwise to raise, anti-clockwise to lower.

#### SEAT SUSPENSION ADJUSTMENT

- Make sure that the indicator 3 is in the green zone.

#### BACKREST ANGLE ADJUSTMENT

- Hold the backrest, push the lever 4 backwards and tilt the backrest to the desired position.

**⚠ IMPORTANT ⚠**

*If you do not support the backrest when making adjustments, it swings completely forwards.*

### DRIVER'S SEAT (OPTION)

DESIGNED FOR MAXIMUM COMFORT, THIS SEAT CAN BE ADJUSTED AS FOLLOWS.

#### SEAT HEIGHT ADJUSTMENT

- Sit down correctly in the seat.
- Turn the knob 1 according to the desired height, clockwise to raise, anti-clockwise to lower, ensuring that the green indicator lamp 2 remains visible.
- If indicator lamp 2 is red, re-adjust the height.

NOTE: The seat is designed so as not to require adjustment according to the driver's weight.

#### LONGITUDINAL ADJUSTMENT

- Pull lever 3 upwards.
- Slide the seat to the desired position.
- Release the lever and be sure it returns to the lock position.

#### BACKREST ANGLE ADJUSTMENT

- Hold the backrest, push the lever 4 backwards and tilt the backrest to the desired position.

**⚠ IMPORTANT ⚠**

*If you do not support the backrest when making adjustments, it swings completely forwards.*

#### HEADREST

- The height of the headrest 5 can be adjusted by pulling it upwards (the notches will click) up to the stop.
- The headrest can be removed by applying sufficient pressure to pull it off the stop.

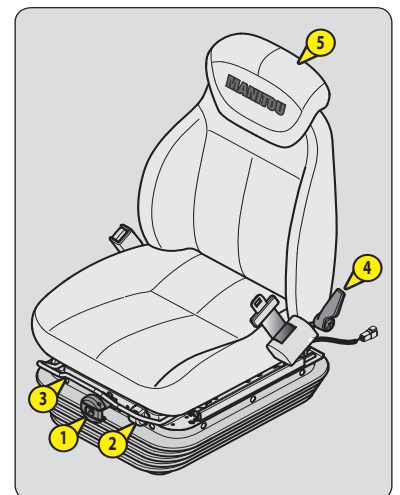
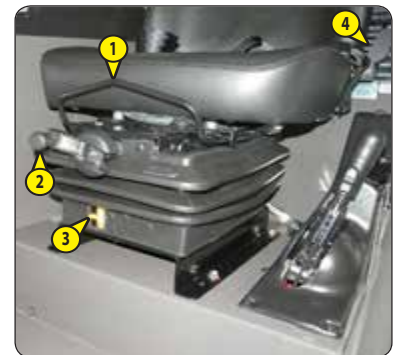



### DRIVER'S PNEUMATIC SEAT (OPTION)

MT 733...

DESIGNED FOR MAXIMUM COMFORT, THIS SEAT CAN BE ADJUSTED AS FOLLOWS.

#### SEAT HEIGHT ADJUSTMENT

- Sit down correctly in the seat.
- Switch on lift truck ignition.
- Pull or push lever 1 according to the desired height, making sure that the green indicator lamp 2 remains visible.
- If indicator lamp 2 is red, re-adjust the height.

NOTE: The seat is designed so as not to require adjustment according to the driver's weight.

#### LONGITUDINAL ADJUSTMENT

- Swing lever 3 upwards.
- Slide the seat to the desired position.
- Release the lever and be sure it returns to the lock position.

#### HORIZONTAL SHOCK ABSORBER

In certain conditions (e.g. driving with a trailer) it is advised that a horizontal shock absorber be used. The driver's seat is thus better able to absorb jerks in the direction of travel.

- Swing lever 3 downwards to block the horizontal damper.

#### BACKREST ANGLE ADJUSTMENT

- Hold the backrest, push the lever 4 backwards and tilt the backrest to the desired position.



*If you do not support the backrest when making adjustments, it swings completely forwards.*

#### HEADREST

- The height of the headrest 5 can be adjusted by pulling it upwards (the notches will click) up to the stop.
- The headrest can be removed by applying sufficient pressure to pull it off the stop.

#### LUMBAR ADJUSTMENT

- Turn knob 6 anti-clockwise to select one of the 5 lumbar support settings.

#### SEAT HEATING

- Switch 7 operates the heating of the seat cushion and the backrest.

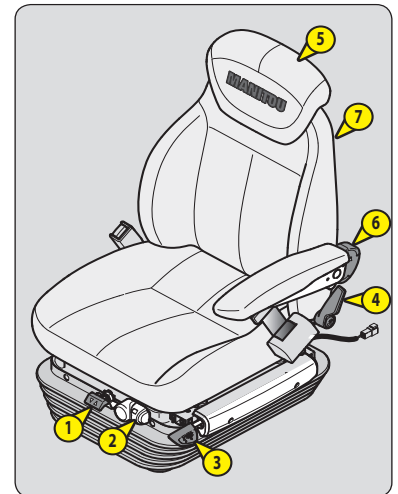

### 3 - SEAT BELT



*Under no circumstances must the lift truck be used if the seat belt is defective (fixing, locking, cuts, tears, etc.).  
Immediately repair or replace the seat belt.*

- Sit correctly on the seat.
- Check that seat belt is not twisted.
- Place the seat belt at hip level.
- Attach the seat belt and check that it locks.
- Adjust the seat belt to your body shape without compressing your pelvis and without excessive slack.

### 4 - IGNITION SWITCH

This switch has 5 positions:

- P - Not used.
- O - Ignition switched off and engine stopped.
- I - Ignition + preheat.
- II - Not used.
- III - Start-up and returns to position I as soon as the key is released.

## 5 - EMERGENCY STOP

In the event of danger, it enables the engine to be shut down, thereby cutting-off all hydraulic movements.

### ⚠ IMPORTANT ⚠

*Be ready for hydraulic movements suddenly stopping when you press this button.  
If possible stop the lift truck before using the emergency stop button.*

- Turn switch to disable.



## 6 - CONTROL AND SIGNAL LIGHTS PANEL

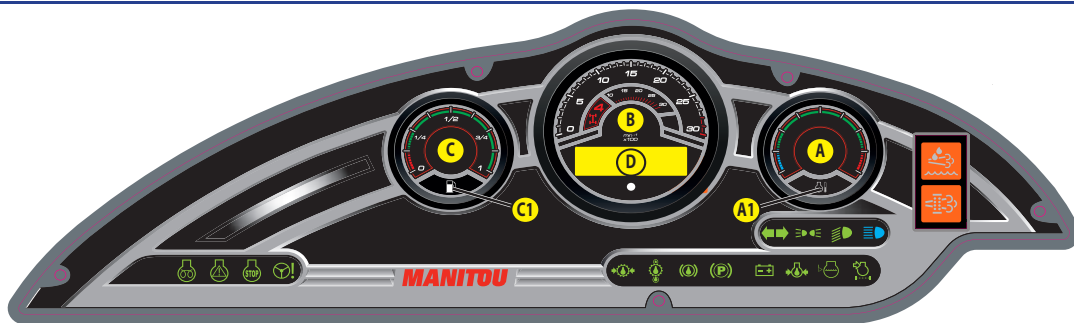

### ⚠ IMPORTANT ⚠

*A permanently lit or flashing warning lamp, with the engine running, is the sign of an operating fault.  
The lighting of some lamps may be accompanied by an audible signal. Do not ignore this warning, consult your dealer without delay.  
If one of the warning lamps comes on while the lift truck is in motion, stop the lift truck under the safest possible conditions.*

When activating the electrical system of the lift truck, all the red and orange lamps and the panel's buzzer must light to indicate their good working order. If one of the red lamps or the buzzer does not function, carry out the necessary repairs.

### A - ENGINE WATER TEMPERATURE





If indicator lamp A1 comes on when the lift truck is running, this means that the coolant temperature is high. Stop the engine immediately and seek the cause of the cooling system malfunction.

### B - REV COUNTER

### C - FUEL LEVEL

Indicator lamp C1 indicates that you are in reserve and that your running time is limited.

### D - SCREEN DISPLAYS

- Turn on the lift truck ignition using the ignition key.
- The  initialisation screen appears, please wait.
- The  screen appears to show:
  - The direction of travel (F for forward/R for reverse/N for neutral).
  - The hour meter.
  - The clock.
- Short press  button A to move successively from one screen to another, hold down the button  to enter the menus.





Main screen.	.....➔	To set the time, short press to increment the value or hold down to move to the next number.	.....➔
Daily hour meter screen.	.....➔	Reset to zero.	
Engine fault screen.	.....➔	Fault code display.	
ECU fault screen.	.....➔	Fault code display.	
Instantaneous consumption screen.			
Countdown to next regeneration screen (700h => 0h).			
Main screen.			

**HELP SCREENS**



FanOff



FanOn

Self-cleaning fan, these screens are displayed for 3 seconds.

**WARNING SCREENS**



Water

This screen is displayed for 3 seconds every 10 minutes in the event that there is water in the diesel. Drain the fuel pre-filter (⏪ 3 - MAINTENANCE: 10H - DAILY OR EVERY 10 HOURS OF SERVICE).



**ENGINE PREHEAT INDICATOR LAMP**

Preheat is necessary. When the lift truck is switched on, the indicator lamp comes on for 2 seconds and goes off as soon as preheat is ended. Start the lift truck's engine.



**ENGINE FAULT INDICATOR LAMP**

If the indicator lamp comes on or flashes while the lift truck is in operation, a diagnostic fault has been detected. The lift truck will operate in reduced mode. Consult your dealer without delay.



**CUT-OFF ENGINE INDICATOR LAMP**

If the indicator lamp lights up or flashes, when the lift truck is running, stop the engine immediately and consult your dealer.



**STEERING SYSTEM OIL PRESSURE WARNING INDICATOR LAMP**

If the indicator lamp lights up when the lift truck is running, stop the engine immediately and determine the cause (possible leak, etc.).



**GEAR BOX OIL PRESSURE WARNING INDICATOR LAMP**

The indicator lamp and buzzer come on when there is an abnormal drop in gear box pressure, in forward gear. Stop the engine and determine the cause (gear box oil level, possible leak, radiator, etc.).

NOTE: This indicator lamp operates in forward travel conditions only, and can be ignored when the lift truck is stopped with the engine running at min rpm.



**GEAR BOX OIL TEMPERATURE WARNING INDICATOR LAMP**

The indicator lamp and buzzer come on when the gear box oil temperature is abnormally high. Stop the engine and determine the cause (gear box oil level, possible leak, radiator, etc.).



**BRAKE FLUID LEVEL WARNING INDICATOR LAMP**

If the indicator lamp and buzzer come on, when the lift truck is running, stop the engine immediately and determine the cause (braking oil level, possible leak, etc.). In the event of an abnormal drop in the level, consult your dealer.



**PARKING BRAKE INDICATOR LAMP**

This indicator lamp comes on when the parking brake is applied.



**BATTERY CHARGE WARNING INDICATOR LAMP**

If the indicator lamp and buzzer come on when the lift truck is running, stop the engine immediately and determine the cause (electric circuit, alternator belt, alternator, etc.).



**ENGINE OIL PRESSURE WARNING INDICATOR LAMP**

If the indicator lamp comes on when the forklift truck is operating, stop the engine immediately and look for the cause (see oil level in engine crankcase).

NOTE: After starting the engine, the indicator lamp remains lit for a few seconds then goes out when the correct engine oil pressure is reached. The full engine power is then available.



**ENGINE WATER LEVEL WARNING INDICATOR LAMP**

If the indicator lamp and buzzer come on when the lift truck is running, stop the engine immediately and determine the cause (coolant level, possible leak, radiator, etc.).



**AIR FILTER OR HYDRAULIC RETURN FILTER CLOGGING WARNING INDICATOR LAMP**

The indicator lamp and the buzzer come on when the air filter cartridge or the hydraulic return oil filter cartridge is clogged. Stop the engine and carry out the necessary repairs (<math>\leq 3</math> - MAINTENANCE: FILTER CARTRIDGES AND BELTS).



**INDICATOR LIGHTS INDICATOR LAMP**



**SIDELIGHTS INDICATOR LAMP**



**LOW BEAM INDICATOR LAMP**



**MAIN BEAM INDICATOR LAMP**



**EXHAUST DECONTAMINATION SYSTEM WARNING INDICATOR LAMP**







The indicator lamp comes on if the system efficiency is defective. Contact your dealer.



**SOOT LEVEL**

If the indicator lamp comes on while the lift truck is operating, perform a "STATIONARY LIFT TRUCK" EXHAUST REGENERATION (↩ 3 - MAINTENANCE; OCCASIONAL MAINTENANCE).

The indicator lamp also comes on when the count (700h => 0h) before next regeneration has elapsed.

Flashing indicator lamp 	-Perform "STATIONARY LIFT TRUCK" EXHAUST REGENERATION.
Fixed  indicator lamp + long audible signal.	-Perform "STATIONARY LIFT TRUCK" EXHAUST REGENERATION.
Fixed  indicator lamp +  + short audible signal.	-Reduced lift truck efficiency, perform "STATIONARY LIFT TRUCK" EXHAUST REGENERATION.
Fixed  indicator lamp +  + short audible signal.	<b>Reduced lift truck efficiency, shut down the lift truck and contact your dealer.</b>

## 7 - LONGITUDINAL STABILITY LIMITER AND WARNING DEVICE

### ⚠ IMPORTANT ⚠

*The operator must respect the lift truck's load chart, and the operating mode according to the attachment.*

This device warns the operator of the lift truck's longitudinal stability limits. However, lateral stability can reduce the load chart in the upper part, and this reduction is not detected by the device.

Depending on the type of work required, the longitudinal stability limiter and warning device allows the operator to operate the lift truck in complete safety.

UPDATE: To gain maximum advantage from the longitudinal stability limiter and warning device of your lift truck, contact your dealer to receive the latest version of the software available.

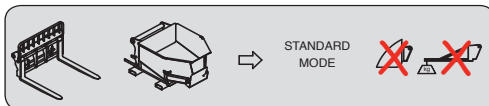
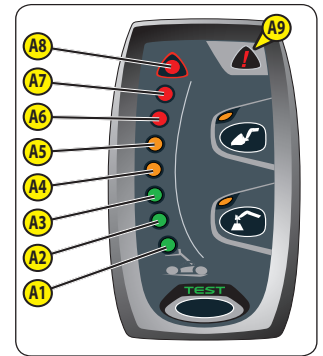

### "HANDLING" MODE

#### USE ON FORKS

- By default, the device is in "HANDLING MODE" each time the lift truck is started.
- Protection against tilting forwards during aggravating movements is guaranteed, except when the telescope is retracted.

STATUS OF THE DEVICE		
HALTED	DRIVING	TELESCOPE(S) RETRACTED
A4-A5 : Very slow intermittent sound alarm. A6 : Slow intermittent sound alarm. A7 : Fast intermittent sound alarm. A8 : Very fast intermittent sound alarm.	- No sound alarm. - Indicator lamp A9 on.	- No sound alarm. - Indicator lamp A9 on.



### "BUCKET" MODE

#### USE WITH BUCKET

- Place the lift truck in the transport position.
- Hold down the  button, "BUCKET" MODE is confirmed by a sound signal and the indicator lamp coming on.
- Press this button again or switch off the ignition with the ignition key to return to "HANDLING" MODE.
- Protection against tilting forwards during aggravating movements is guaranteed, except when the telescope is retracted.

STATUS OF THE DEVICE		
HALTED	DRIVING	TELESCOPE(S) RETRACTED
- The "BUCKET" mode deactivates automatically if the lift truck remains stationary.	- No sound alarm. - Indicator lamp A9 on.	- No sound alarm. - Indicator lamp A9 on.



### "SUSPENDED LOAD" MODE

#### USE WITH LIFTING DEVICE (offering a higher margin of safety)

- Place the lift truck in the transport position.
- Press the  button, the "SUSPENDED LOAD" MODE is confirmed by a sound signal and the indicator lamp coming on. Hydraulic tilting movements are neutralised, as well as the lifting movement when the longitudinal stability limit is reached (indicator lamp A8 lit).
- Press this button again or switch off the ignition with the ignition key to return to "HANDLING" MODE.
- Protection against tilting forwards during aggravating movements is guaranteed, except when the telescope is retracted.



STATUS OF THE DEVICE		
HALTED	DRIVING	TELESCOPE(S) RETRACTED
A4-A5 : Very slow intermittent sound alarm. A6 : Slow intermittent sound alarm. A7 : Fast intermittent sound alarm. A8 : Very fast intermittent sound alarm.	-No sound alarm. -Indicator lamp A9 on.	-No sound alarm. -Indicator lamp A9 on.

**A - VISUAL ALARMS**

- A1 - A2 - A3: There is a significant reserve of longitudinal stability.
- A4 - A5: The lift truck is approaching the limit of longitudinal stability, move with care.
- A6: The lift truck is close to the longitudinal stability limit. Manoeuvre with care.
- A7: The lift truck is very close to the longitudinal stability limit. Manoeuvre with extreme caution.
- A8: The lift truck is at the authorised limit of longitudinal stability.
- A9: The "AGGRAVATING" hydraulic movement cut-off is disabled.

**B - HYDRAULIC MOVEMENT CUT-OFF**

"HANDLING" MODE

- A8: All "AGGRAVATING" hydraulic movements are cut off. Only perform de-aggravating hydraulic movements in the following order: retract and raise the boom.

"BUCKET" MODE

- A8: The boom lowering and extension movements are cut off, the other movements remain available.

"SUSPENDED LOAD" MODE

- A8: All "AGGRAVATING" and boom raising hydraulic movements are cut off. Only the boom retraction hydraulic movement is available.

**C - DISABLING "AGGRAVATING" HYDRAULIC MOVEMENT CUT-OFF**



*Remain very vigilant during this operation. The only information available to the operator is the lift truck's dynamic stability.*

In certain cases, in order to get out of a difficult situation, the operator can bypass this safety device. Button C temporarily disables the cut-off of "AGGRAVATING" hydraulic movements.

- Hold down button C, indicator lamps A9 and C1 will light (60 second time delay), and at the same time perform the necessary "AGGRAVATING" hydraulic movement with extreme care.



**D - TESTING THE LONGITUDINAL STABILITY LIMITER AND WARNING DEVICE**

- Press briefly on the  button at any time to verify that the longitudinal stability alarm is working.
  - Correct operation: All the LEDs light for two seconds and an audible signal is sounded.

NOTE: This test does not make it possible to check the correct adjustment of the longitudinal stability limiter device which must be inspected daily or after every 10 hours of operation (← 3 - MAINTENANCE: 10H - DAILY SERVICE OR EVERY 10 HOURS OF SERVICE).

**E - FAULT INDICATOR LAMP**

A permanently lit fault indicator lamp , together with an audible signal, indicates a major fault liable to affect the safety of the lift truck. Refer to your agent or dealer.

- Consult the screen for the fault code.

**F - STRAIN GAUGE**



*Disassembly or calibration of the strain gauge is prohibited, this must only be done by specially trained personnel, consult your dealer.*

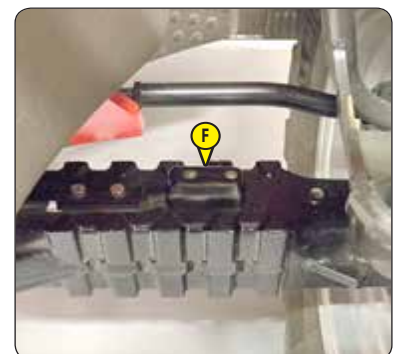

## 8 - SWITCHES

The location of the switches may vary depending on the options.



### BOOM ELECTRICAL PREDISPOSITION (OPTION)

◀ DESCRIPTION AND USE OF THE OPTIONS



### BOOM HEAD ELECTROVALVE (OPTION)

◀ DESCRIPTION AND USE OF THE OPTIONS



### DISABLING "AGGRAVATING" HYDRAULIC MOVEMENT CUT-OFF

◀ LONGITUDINAL STABILITY LIMITER AND WARNING DEVICE



### HAZARD WARNING LIGHTS



### REAR FOG LIGHTS



### SELF-CLEANING FAN (OPTION)

◀ DESCRIPTION AND USE OF THE OPTIONS



### STEERING SELECTION



### TRANSMISSION CUT-OFF

NOTE: In all cases transmission cut-off can be activated using the gear lever.

- Position 1: Indicator lamp is on, transmission is cut off with the service brake pedal and the forward/neutral/reverse gear lever.
- Position 2: Indicator lamp is off, transmission is cut off with the forward/neutral/reverse gear selector.

#### USE OF TRANSMISSION CUT-OFF

- Transmission cut-off to brake pedal (position 1).
  - When loading.
- Transmission cut-off with forward/neutral/reverse gear selector (position 2).
  - When driving.
  - For inching and continuous stop/start (delicate handling).
  - Start-up on a slope.



### ROTATING BEACON LIGHT



### FRONT WORKING LIGHTS (OPTION)



### REAR WORKING LIGHTS (OPTION)



### FRONT AND REAR WORKING LIGHTS (OPTION)



### BOOM HEAD WORKING LIGHTS (OPTION)



### REAR WINDOW DEFROSTER (OPTION)



### ROOF WINDSCREEN WIPER + SIDE WINDSCREEN WIPER (OPTION)





**ATTACHMENT EASY HYDRAULIC CONNECTION (OPTION)**

< DESCRIPTION AND USE OF THE OPTIONS



**BOOM SUSPENSION (OPTION)**

< DESCRIPTION AND USE OF THE OPTIONS



**EXHAUST REGENERATION**

< 3 - MAINTENANCE: OCCASIONAL MAINTENANCE



**OPTION**



**GREEN ROTATING BEACON LIGHT (OPTION)**



**ATTACHMENT HYDRAULIC LOCKING (OPTION)**

< DESCRIPTION AND USE OF THE OPTIONS



**HYDRAULIC MOVEMENT NEUTRALISATION**

When driving on the road, it is highly recommended (mandatory in Germany) that you cut off all the hydraulic movements. The indicator lamp shows when it is in use.

MT 733...  
MT 933...



**ATTACHMENT EASY HYDRAULIC CONNECTION (OPTION)**

< DESCRIPTION AND USE OF THE OPTIONS



**EXHAUST REGENERATION**

< 3 - MAINTENANCE: OCCASIONAL MAINTENANCE



**ATTACHMENT HYDRAULIC LOCKING (OPTION)**

< DESCRIPTION AND USE OF THE OPTIONS



**HYDRAULIC MOVEMENT NEUTRALISATION**

When driving on the road, it is highly recommended (mandatory in Germany) that you cut off all the hydraulic movements. The indicator lamp shows when it is in use.



**STABILISERS SET DOWN INDICATOR LAMPS**



**OPTION**



**GREEN ROTATING BEACON LIGHT (OPTION)**

MT 1033...





### 9 - LIGHTING, HORN AND INDICATOR SWITCH

The switch controls the visual and sound alarms.

- A - All lights are off, the indicator lights do not flash.
- B - The right hand indicator lights flash.
- C - The left hand indicator lights flash.
- D - Sidelights and rear lights on.
- E - The dipped headlights and the rear lights are on.
- F - The main beam headlights and the rear lights are on.
- G - Headlight signalling.

Pressing the end of the switch sounds the horn.

NOTE: Positions D - E - F - G can be used without switching on the ignition.

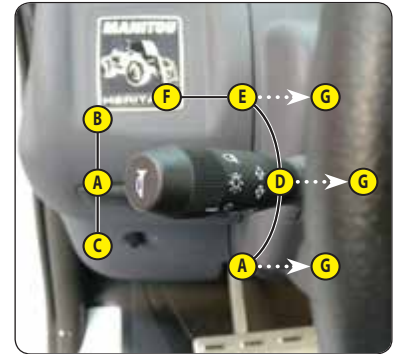

### 10 - FRONT AND REAR WINDSCREEN WIPER SWITCH

FRONT WINDSCREEN WIPER

- A - Front windscreen wiper off.
- B - Front windscreen wiper low speed setting.
- C - Front windscreen wiper high speed setting.
- D - Front windscreen wiper pulse driven.

REAR WINDSCREEN WIPER

- F - Rear windscreen wiper off.
- G - Rear windscreen wiper on.
- H - Rear windscreen washer, pulse driven (not used).

NOTE: These functions will only work when the ignition is switched on.

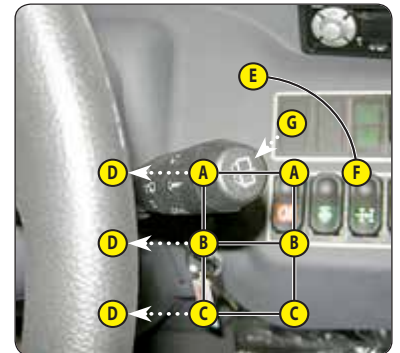

### 11 - STEERING SELECTION

#### A - GREEN WHEEL ALIGNMENT INDICATOR LAMPS

**⚠ IMPORTANT ⚠**

*Before selecting one of the three steering possibilities, align the 4 wheels in relation to the lift truck axis.  
Never change the steering mode whilst driving.*

These green indicator lamps come on to indicate the alignment of the wheels in relation to the lift truck. The A1 indicator lamp for the front wheels and the A2 indicator lamp for the rear wheels.

#### B - STEERING SELECTION LEVER

- B1 - Front steering wheels (road mode).
- B2 - Front and rear steering wheels in opposite directions (short steering).
- B3 - Front and rear steering drive wheels in the same direction (crab steering).

CHECKING WHEEL ALIGNMENT

**⚠ IMPORTANT ⚠**

*Check the alignment of the front and rear wheels each time the lift truck is started.*

*Regularly check the alignment of the wheels when using the lift truck.*

*The wheels must be aligned and the lift truck must be in front steering wheels mode when used on public roads.*

*A green light comes on on the dashboard when the wheels are aligned.*

*Contact your dealer if you have any questions.*

- Select "short steering" (position B2).
- Turn the steering wheel and bring the rear wheels into alignment until the A2 indicator lamp comes on.
- Select "road driving" (position B1).
- Turn the steering wheel and bring the front wheels into alignment until the A1 indicator lamp comes on.

#### C - SWITCH FOR ALIGNMENT OF THE WHEELS

This switch enables or disables the wheel alignment device. The indicator lamp indicates that it is in use.

- When driving on the road, disable the wheel alignment device.





## 12 - FUSES AND RELAYS IN THE CAB

A sticker on the inside of the access panel provides a quick indication of the use of the fuse plate's components described below.

- Remove the access panel 1 to access the fuses and relays. Replace a used fuse with a new fuse of the same quality and capacity. Never reuse a repaired fuse.



### MINIFUSE

F1	7,5A	Rear camera (OPTION).
F2	15A	Rear working lights (OPTION). Rear windscreen wiper.
F3	10A	Roof windscreen wiper. Side windscreen wiper (OPTION).
F4	7,5A	Engine ECU wake-up. Diagnostic plug. Transmission and hydraulic oil temperature sensor. Fuel decongealant (OPTION).
F5	7,5A	Rotating beacon light. Green rotating beacon light (OPTION).
F6	5A	Wheel alignment. Stabiliser indicator lamps. MT 1033... OPTION.
F7	7,5A	Longitudinal stability limiter and warning device. Deactivation of aggravating hydraulic movement cut-off.
F8	15A	JSM joystick. Transmission cut-off. Relay K2, K3, K4.
F9	5A	Control panel. Relay K17.
F10	10A	Horn. Stop switch.
F11	15A	Working lights on boom (OPTION).
F12	10A	Flashing unit.
F13	20A	Fan/heating.
F14	10A	12 V plug.
F15	20A	Hydraulic movement control unit. Diagnostic plug. Heater relay control.
F16	5A	Self-cleaning fan (OPTION). Anti-theft system (OPTION).
F17	10A	Front working lights (OPTION).
F18	15A	Rear windscreen defrost (OPTION).
F19	15A	Pneumatic seat (OPTION).
F20	10A	Front windscreen wiper. Front windscreen washer.
F21	10A	Boom electrical predisposition (OPTION). Boom head electrovalve (OPTION).
F22	10A 15A	Boom suspension (OPTION). MT 733... - MT 933...
F23	7,5A	Right sidelights. Control panel illumination.
F24	7,5A	Left sidelights. Licence plate lighting (OPTION).
F25	7,5A	Right indicator lights.
F26	7,5A	Left indicator lights.
F27	15A	Dipped beam headlights. Rear fog lights.
F28	15A	Main beam headlights.
F29	15A	Hazard warning lights. Roof light. Anti-theft device predisposition. Rev counter.
F30	25A	Lighting, horn and indicator switch.
F31	5A	Starter relay.
F32	5A	Diagnostic plug. Hydraulic movement control unit power supply.
F33	2A	Control panel power supply.

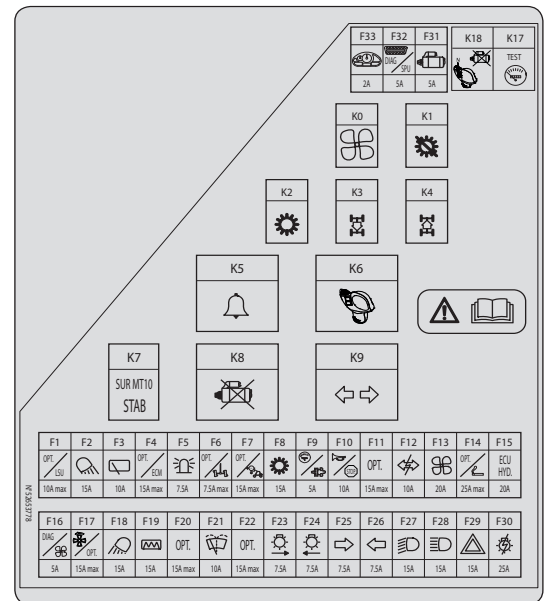



**RELAYS**

K0	OPTION.
K1	Transmission cut-off relay.
K2	Transmission cut-off relay.
K3	Reverse gear relay.
K4	Forward gear relay.
K5	Buzzer.
K6	JSM activation relay.
K7	OPTION. MT 733... - MT 933... Stabiliser relay. MT 1033...
K8	Starter safety relay.
K9	Flashing unit.
K10	Boom suspension cut-off relay (OPTION). MT 733... - MT 933...
K11	Boom suspension power supply relay (OPTION). MT 733... - MT 933...
K17	Indicator lamps module relay.
K18	Neutral safety relay.

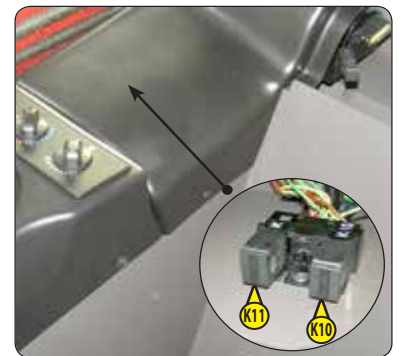
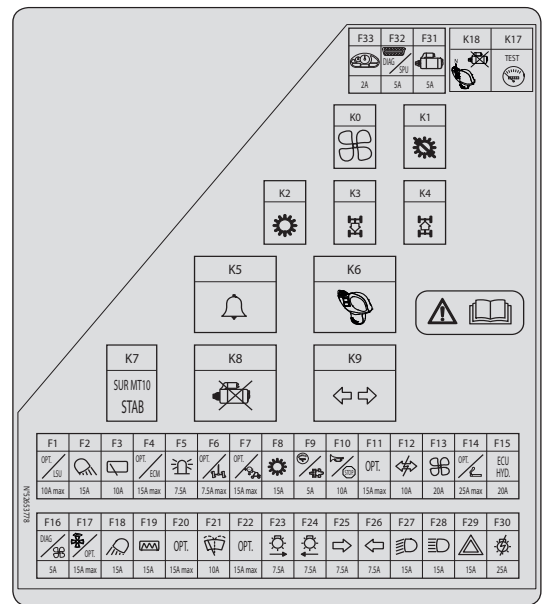

**13 - FUSES AND RELAYS UNDER THE ENGINE COVER**

- Open the engine bonnet, remove cover 1 to gain access to the fuses and relays. Replace a used fuse with a new fuse of the same quality and capacity. Never reuse a repaired fuse.

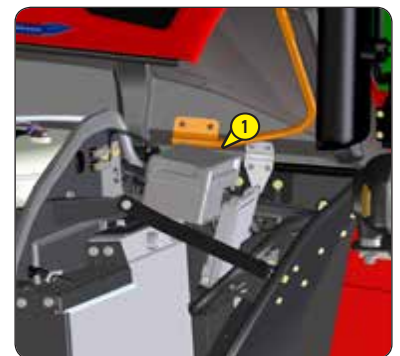

**MINIFUSE**

F41	5A	Engine diagnostic plug
F42		Free.
F43		Free.
F44	30A	Fuel decongealant (OPTION).
F45	15A	Relay power supply K23.
F46	30A	Air conditioning (OPTION).

**MAXIFUSE**

F47	30A	Engine control power unit.
F48	60A	Relay power supply K21.
F49	80A	Ignition switch.

**RELAYS**

K21	Engine preheat.
K23	Fuel pump.

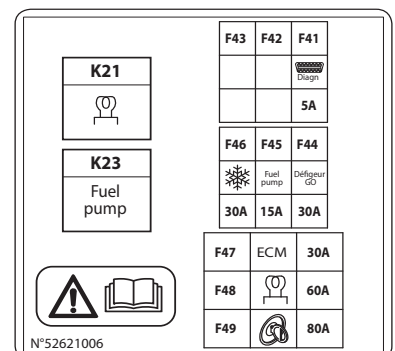

## 14 - DIAGNOSTIC PLUG



## 15 - ACCELERATOR PEDAL

## 16 - SERVICE BRAKE PEDAL AND TRANSMISSION CUT-OFF

The pedal acts on the front and rear wheels via a power assisted hydraulic braking system that slows the lift truck and brings it to a halt. Depending on the position of the transmission cut-off switch, it enables the transmission to be cut off during the free travel.

## 17 - GEAR LEVER AND TRANSMISSION CUT-OFF

In order to change gear, it is necessary to cut off the transmission by pressing button 1 on the lever.

### USING THE GEARS ON THE GEAR BOX

On lift trucks such as these, that are equipped with torque converters, it is not necessary to systematically set off in first gear and work up through the gears.

#### **⚠ IMPORTANT ⚠**

*The gear box ratio selection should be made carefully depending on the work to be performed. A poor choice may result in the extremely rapid rise of the gear box oil temperature through excessive slipping of the converter, which could lead to serious gearbox damage (it is essential to stop and change the working conditions if the gear box oil temperature indicator lamp comes on).*

*This poor choice may also result in the forklift truck's performance deteriorating in forward gear. When the forward force increases, the forward speed in the r ratio (for example, in 3rd gear) may be lower than the forward speed that could be obtained with the r-1 gear (in 2nd instead of 3rd).*

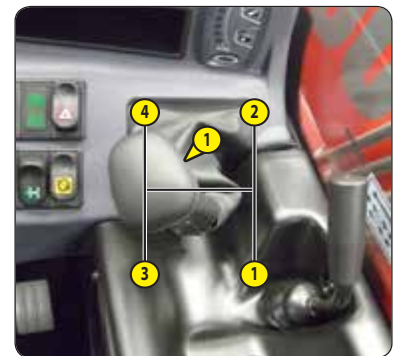

In general, we would advise you to use the following gears according to the nature of the work being carried out.

- ON THE ROAD: Set off in 3rd gear and change up to 4th if the conditions and state of the road permit it. In hilly areas, set off in 2nd gear and change up to 3rd if the conditions and state of the road permit it.
- WITH A TRAILER ON THE ROAD: Set off in 2nd gear and change up to 3rd if the conditions and state of the road permit it.
- HANDLING: Use 3rd gear. In confined spaces use 2nd gear.
- LOADING (picking-up with bucket, manure fork, etc.): Use 2nd gear.
- EARTH MOVING: Use 1st gear.

## 18 - PARKING BRAKE LEVER

To prevent accidental loosening or release, the lever is fitted with safety locking.

- To apply the parking brake, pull the lever backwards (position A).
- To loosen the parking brake, release and push the lever forwards (position B).

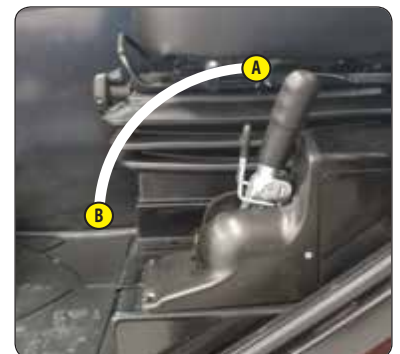

### 19 - FORWARD/NEUTRAL/REVERSE GEAR SELECTION

When changing the direction of travel, the lift truck should be travelling at slow speed and not accelerating.

- FORWARD: Push the switch forward (position A).
- REVERSE: Push the switch backward (position B). Reversing lights and an acoustic reversing alarm indicate that the lift truck is travelling in reverse.
- NEUTRAL: The switch must be in the neutral position (position C) to start the lift truck.

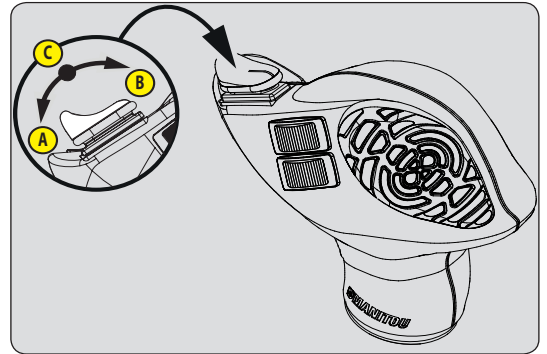

### SAFETY FOR MOVING THE LIFT TRUCK

The operator must observe the following sequence to move the truck forwards or backwards:

- 1 - sit down correctly in the driver's seat,
- 2 - release the hand brake,
- 3 - engage forward or reverse.

NOTE: The alternating display of F/N or R/N on the screen and a rapid, discontinuous audible signal indicates that the selector needs to be set to neutral.

To stop the forklift truck without switching off the ignition, the following sequence must be followed:

- 1 - Set the forward/reverse selector to neutral,
- 2 - Apply the parking brake,
- 3 - Get out of the lift truck.

NOTE: A discontinuous audible signal and a message on the screen will inform the driver if he has left the driver's cab without applying the parking brake.

### 20 - HYDRAULIC CONTROLS

**⚠ IMPORTANT ⚠**

*Do not attempt to alter the hydraulic system pressure by interfering with the pressure regulating valve. In the event of suspected malfunction, contact your dealer. ANY ALTERATION MAY RENDER THE WARRANTY NULL AND VOID AND INCURS LIABILITY IN THE EVENT OF AN ACCIDENT.*

*Use the hydraulic controls gently without jerking, to avoid incidents caused by shaking the lift truck.*

NOTE: If necessary, operate the steering to reset the hydraulic control steering accumulator.

### HYDRAULIC CONTROLS ACTIVATION

This safety device prevents accidental operation of the hydraulic lifting, tilting, telescoping and attachment controls.

USING THE BUTTON	USING THE CAPACITIVE SENSOR
<p>-Place your hand on the lever, activate the hydraulic controls by pressing the button and perform the hydraulic movement.</p>	<p>-Place your hand on the lever, activate the hydraulic controls by contact on the capacitive sensor and perform the hydraulic movement.</p>
<p>-Hydraulic controls activation is maintained on a timer while the lift truck is being used. -If necessary, reactivate the hydraulic controls.</p>	

**A1 - LIFTING**

**A2 - LOWERING**

**B1 - EXCAVATION**

**B2 - DUMP**

**C1 - TELESCOPE EXTENSION**

**C2 - TELESCOPE RETRACTION**

**D1 - ATTACHMENT**

**D2 - ATTACHMENT**

**E - BOOM ELECTRICAL PREDISPOSITION (OPTION)**

**BOOM HEAD ELECTROVALVE (OPTION)**

(↖ DESCRIPTION AND USE OF THE OPTIONS).

**F1 - LOWERING LEFT STABILISER MT 1033 ...**

**F2 - LIFTING LEFT STABILISER MT 1033 ...**

**G1 - LOWERING RIGHT STABILISER MT 1033 ...**

**G2 - LIFTING RIGHT STABILISER MT 1033 ...**

NOTE: The stabilisers can only be raised after the jib has been retracted.

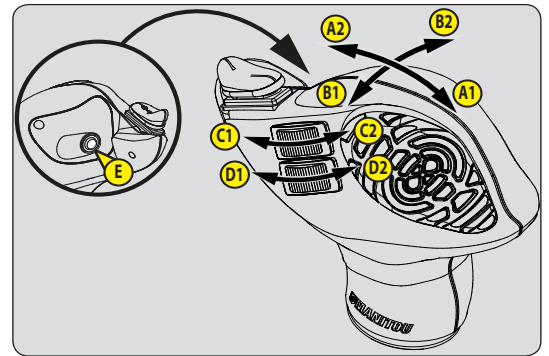

## 21 - FUNCTION FILES

These files contain the description of the hydraulic controls and the load charts for the attachments used on the lift truck.



## 22 - LEVEL INDICATOR

Enables the operator to check that the lift truck is in the horizontal position.





### 23 - HEATER CONTROL

#### A - FAN CONTROL

This 4-speed control allows the air to be ventilated through the air vents.

#### B - TEMPERATURE CONTROL

Adjusts the temperature inside the cab.

- B1 - The fan pumps in the air at ambient temperature.
- B2 - The fan pumps in warm air.

The intermediate positions allow the temperature to be adjusted.



### 24 - AIR CONDITIONING CONTROLS (AIR CONDITIONING OPTION)

#### ⚠ IMPORTANT ⚠

*The air conditioning only works if the lift truck has been started.*

*When using your air conditioning, it is essential to work with the cab closed.*

*In winter: So as to ensure that the air conditioning unit is correctly operated and completely efficient, start up the compressor once a week, even for a short period of time, in order to lubricate the internal seals.*

*In cold weather: Warm the engine before switching on the compressor, in order to allow the coolant that has collected in the liquid state at the lowest point of the compressor's circuit to turn into gas under the effect of the heat given off by the engine, as the compressor is liable to be damaged by coolant in the liquid state.*

*If your air conditioning does not seem to be working correctly, have it examined by your dealer.*

*Never try to repair any faults yourself.*

#### A - FAN CONTROL

This 3-speed control allows the air to be ventilated through the air vents.

#### B - TEMPERATURE CONTROL

Adjusts the temperature inside the cab.

- B1 - The fan pumps in cold air.
- B2 - The fan pumps in warm air.

The intermediate positions allow the temperature to be adjusted.



#### C - AIR CONDITIONING CONTROL

This control with a pilot light allows the air conditioning unit to be switched on.

##### HEATING MODE

- The controls must be adjusted in the following way:
  - C - Control with pilot light off.
  - B - At the desired temperature.
  - A - At the desired speed: 1, 2 or 3.

##### AIR CONDITIONING MODE

- The controls must be adjusted in the following way:
  - C - Control with pilot light on.
  - B - At the desired temperature.
  - A - At the desired speed: 1, 2 or 3.

##### DEMISTING MODE

- The controls must be adjusted in the following way:
  - C - Control with pilot light on.
  - B - At the desired temperature.
  - A - At speed 2 or 3.
- For optimum effectiveness, close the heating ventilators.

### 25 - WINDSCREEN DEMISTER VENTS

For optimum effectiveness, close the heating ventilators.

### 26 - HEATING VENTS

These swivelling heating vents, which can be shut off, allow you to direct and adjust the flow inside the cab.

### 27 - STEERING WHEEL ADJUSTMENT LEVER (OPTION)

This handle enables the angle and height of the steering wheel to be adjusted.

- Pull the knob backwards.
- Adjust the steering wheel to the desired position.
- Push the knob back to lock the steering wheel in position.



### 28 - DOOR OPENING HANDLE

Two keys are provided with the lift truck to enable the cab to be locked.

- Pull on the handle to open the door.



### 29 - LOCKING HANDLE FOR UPPER HALF-DOOR

- Pull on the handle to release the upper half-door.
- Open the half-door fully and make sure it is locked in the open position.



### 30 - UNLOCKING BUTTON FOR UPPER HALF-DOOR

### 31 - HANDLE FOR REAR WINDOW OPENING

#### **EMERGENCY EXIT**

Use the rear window as an emergency exit, in the event that it is impossible to leave the cab by the door or by opening the windscreen.



### 32 - STORAGE COMPARTMENT

There is an OPTIONAL cover for the storage compartment.



### 33 - STORAGE NET

Ensure that the operator's manual is in its place in the storage net.

**34 - SUN VISOR (OPTION)**

---

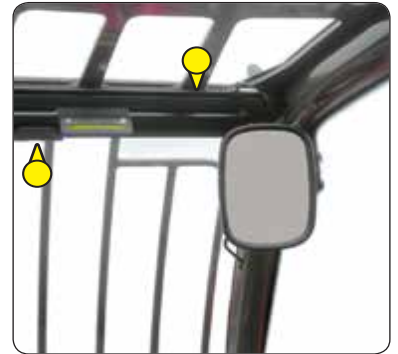

**35 - ROOF LIGHT**

---

**36 - HOOK**

---



**37 - INSIDE REAR-VIEW MIRROR (OPTION)**

---



**38 - ARMREST**

MT 733... - MT 933...

Lift the armrest to access the storage.

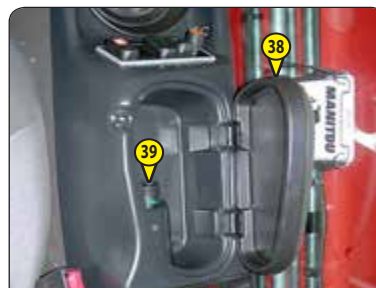

MT 733...  
MT 933...

**39 - 12V SOCKET**

---

For 12 V appliance and max. amperage 15A.



MT 1033...



#### 40 - BATTERY CUT-OFF

For quickly disconnecting the battery when working on the electric circuit or when soldering, for example.

**⚠ IMPORTANT ⚠**

*Operate the battery cut-off no less than 30 seconds after turning off the ignition with the ignition key.*



#### 41 - FRONT HEADLIGHTS

- A - Front left-hand indicator light.
- B - Front left-hand dipped headlight.
- C - Front left-hand headlight.
- D - Front left-hand sidelight.
- E - Front right-hand indicator light.
- F - Front right-hand dipped headlight.
- G - Front right-hand headlight.
- H - Right front sidelight.



#### 42 - REAR LIGHTS

- A - Rear left-hand indicator light.
- B - Rear left-hand stop light.
- C - Rear left-hand headlight.
- D - Rear left-hand reversing light.
- E - Rear left-hand fog light.
- F - Rear right-hand fog light.
- G - Rear right-hand reversing light.
- H - Rear right hand headlight.
- I - Rear right-hand stop light.
- J - Rear right-hand indicator light.

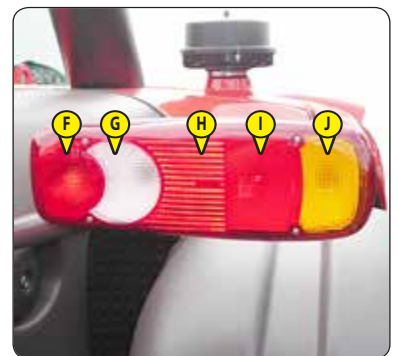
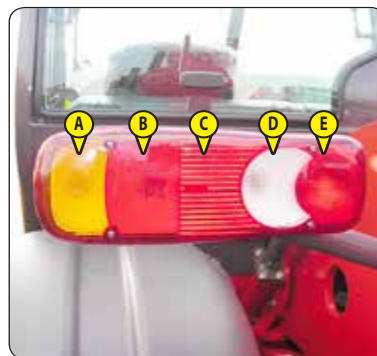

#### 43 - ROTATING BEACON LIGHT

The magnetic rotating beacon light must be clearly visible on the roof of the cab and plugged into socket 1.





#### 44 - BOOM SAFETY WEDGE

**⚠ IMPORTANT ⚠**

*Only use the wedge supplied with the lift truck.*

The lift truck is equipped with a boom safety wedge which must be installed on the rod of the lifting cylinder when working beneath the boom (☞ 1 - OPERATING AND SAFETY INSTRUCTIONS).



#### 45 - FUEL TANK

As far as possible, keep the fuel tank well filled in order to minimise condensation due to the atmospheric conditions.

**⚠ IMPORTANT ⚠**

*Never smoke or approach with a flame during filling operations or when the tank is open.*

*Never refill while engine is running.*

- If necessary, add diesel (☞ 3 - MAINTENANCE: LUBRICANTS AND FUEL).
- Remove the cap 1.
- Fill the fuel tank with clean diesel filtered through the filler port.
- Refit the cap.
- Visually check that there is no leakage in the tank and pipes.

NOTE: A locking tank cap is available as an OPTION.







## TOWING DEVICE

### ⚠ IMPORTANT ⚠

*Do not tow a trailer or an attachment that is not in perfect working condition.  
Using a trailer in poor condition may affect the lift truck's steering and braking, and hence the safety of the assembly.  
If a third party helps in coupling or uncoupling the trailer, this person must be permanently visible to the driver and wait until the lift truck has stopped, the handbrake is on and the I.C. engine is switched off before performing the operation.*

Located at the rear of the lift truck, this device is used to couple a trailer. Capacity is limited for each lift truck by the authorised gross vehicle weight (AGVW), tractive effort and maximum vertical force on the coupling point. This information is given on the manufacturer's plate fixed to each lift truck (← IDENTIFICATION OF THE LIFT TRUCK).

- To use a trailer, see current regulations in your country (maximum running speed, braking, maximum weight of trailer, etc.).
- Verify the trailer's condition before using it (tyre condition and pressures, electrical connection, hydraulic hose, brake system...).

### 1 - CLEVIS HITCH

#### ⚠ IMPORTANT ⚠

*Be careful not to get your fingers caught or crushed during this operation.  
Do not forget to put the cotter pin back in place.  
When uncoupling, make sure that the trailer is supported independently.*

#### COUPLING AND UNCOUPLING THE TRAILER

- To couple the trailer, position the lift truck as close as possible to the trailer ring.
- Apply the handbrake on and switch off the engine.
- Remove the pin 1, lift the towing pin 2 and place or remove the trailer ring.

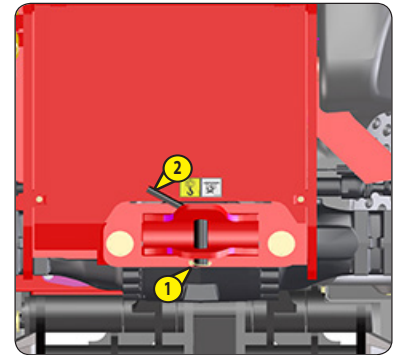

### 2 - REAR ELECTRIC SOCKET (OPTION)

- Connect the male plug to the female socket 1 on the lift truck and make sure the lights of the trailer or the light bar are working properly.

- 1 - Ground.
- 2 - Left rear light and number plate.
- 3 - Rear left-hand indicator light.
- 4 - Rear brake lights.
- 5 - Rear right-hand indicator light.
- 6 - Rear right hand headlight.
- 7 - Not used.

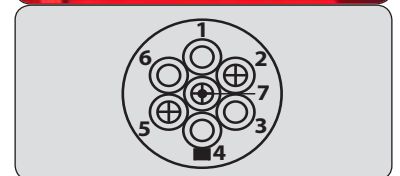

### 3 - REAR-VIEW MIRROR

The rear-view mirror allows the lift truck to approach the trailer ring more precisely.

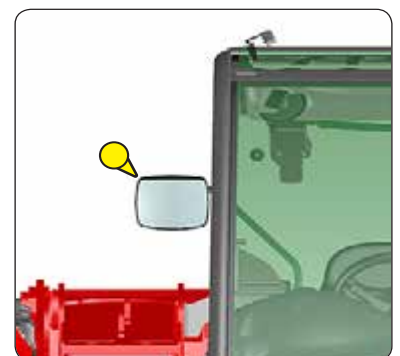





## DESCRIPTION AND USE OF THE OPTIONS

1 - WINDSCREEN GRILL .....	2-61
2 - REAR WINDOW STAY .....	2-61
3 - PROTECTIVE GRILLE FOR HEADLIGHTS AND REAR LIGHTS.....	2-61
4 - TOOL BOX .....	2-61
5 - WATERPROOF DOCUMENT HOLDER .....	2-61
6 - BOOM HEAD SEALING .....	2-62
7 - ANGULAR SECTOR ON BOOM .....	2-62
8 - "A-B-C-D-E" MARKING ON BOOM .....	2-62
9 - LICENSE PLATE LIGHT .....	2-62
10 - ANTI-THEFT SYSTEM MODCOD.....	2-62
11 - SELF-CLEANING FAN CLEANFIX .....	2-63
12 - FUEL DECONGEALANT .....	2-63
13 - PREHEAT ROD .....	2-63
14 - GREEN ROTATING BEACON LIGHT .....	2-63
15 - REAR CAMERA .....	2-64
16 - ENGINE SPEED REGULATOR.....	2-64
17 - BOOM ELECTRICAL PREDISPOSITION.....	2-64
18 - ATTACHMENT CIRCUIT WITH QUICK-RELEASE COUPLERS .....	2-64
19 - EXTERIOR DRAIN-BACK.....	2-65
20 - ATTACHMENT HYDRAULIC CONTROL FORCED OPERATION.....	2-65
21 - BOOM SUSPENSION.....	2-65
22 - ATTACHMENT EASY HYDRAULIC CONNECTION.....	2-66
23 - ATTACHMENT HYDRAULIC LOCKING.....	2-66
24 - BOOM HEAD ELECTROVALVE .....	2-67
25 - BOOM HEAD ELECTROVALVE + HYDRAULIC ATTACHMENT LOCKING.....	2-67
26 - LIFTING RING ON SINGLE CARRIAGE.....	2-68

### 1 - WINDSCREEN GRILL

**DESCRIPTION**

The windscreen grill provides additional protection for the operator from any external elements spattered on the windscreen.

This grill must be removable from inside the cab to enable an emergency exit.

**EMERGENCY EXIT**

- After breaking the windscreen with the emergency hammer, push (with force) on the windscreen grill at A to remove it.



### 2 - REAR WINDOW STAY

- Holds the rear window half-open.



### 3 - PROTECTIVE GRILLE FOR HEADLIGHTS AND REAR LIGHTS



### 4 - TOOL BOX



### 5 - WATERPROOF DOCUMENT HOLDER



## 6 - BOOM HEAD SEALING

---



## 7 - ANGULAR SECTOR ON BOOM

---

The angular sector displays the boom angle, and thus improves the reading of the load charts.



## 8 - "A-B-C-D-E" MARKING ON BOOM

---

The marking indicates the outreach of the boom and therefore improves reading of the load charts.

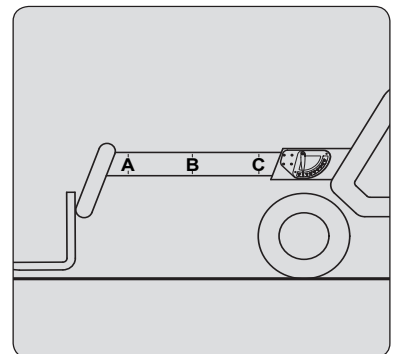

## 9 - LICENSE PLATE LIGHT

---



## 10 - ANTI-THEFT SYSTEM MODCOD

---

### OPERATION

- Switch on the lift truck: the red indicator 1 will flash.
- Enter your user code followed by "V" to validate: the green indicator 2 will come on.
- Start the lift truck within the next 60 seconds; otherwise the anti-theft system will be reactivated and the red indicator 1 will flash.

NOTE: If you make a mistake when entering the code, press key "A" to cancel and re-enter the code in full. If you wait more than 5 seconds between key presses or do not complete entering the code, the anti-theft system will be reactivated and the red indicator will flash.



### 11 - SELF-CLEANING FAN CLEANFIX

Cleans the radiator core and the grille of the engine cover by reversing the air flow.

**⚠ IMPORTANT ⚠**

*When in use, beware of the risk of projection into the eyes.*

#### OPERATION

- Set switch 1 to position A (indicator light on), the fan operates in self-cleaning mode for a few seconds once every 3 minutes.
- Set switch 1 to position B (indicator light on), the fan operates normally.



### 12 - FUEL DECONGEALANT

The paraffin particles found naturally in diesel crystallise at low temperatures. The fuel decongealant helps to limit accumulation in the filter.

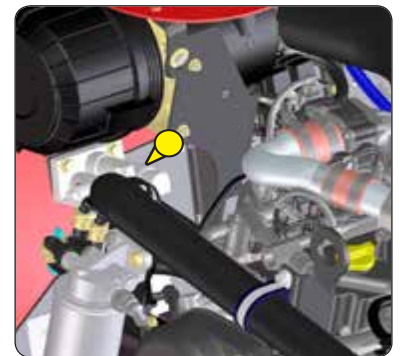

### 13 - PREHEAT ROD

Enables the engine to be kept warm during prolonged periods of stoppage and thus improves engine starting.

#### ENVIRONMENTAL CONDITIONS FOR USE:

- Maximum ambient temperature for using preheating: + 25 °C.

#### CONDITIONS FOR CONNECTION AND USE OF PREHEATING:

- The preheating system should not be used for an external ambient temperature higher than + 25 °C.
- It is essential that the power supply to the preheating system:
  - Is effected with a cable that conforms to the installation standards in force and contains a protective earth conductor.
  - Contains an appropriate sectioning system.
  - Incorporates an appropriate safety system against short circuits (fuses or circuit breaker) and a differential circuit breaker with 30 mA sensitivity.
- Only connect to and disconnect from the power supply while the unit is switched off and the engine is stopped.

**⚠ IMPORTANT ⚠**

*Make sure that the electrical extension is still correctly stored in its place in the document holder net.*



### 14 - GREEN ROTATING BEACON LIGHT

The magnetic green rotating beacon light must be clearly visible on the roof of the cab and plugged in to socket 1.

- It indicates that the operator has fastened the seat belt.
- Do not use the green rotating beacon light on public roads.

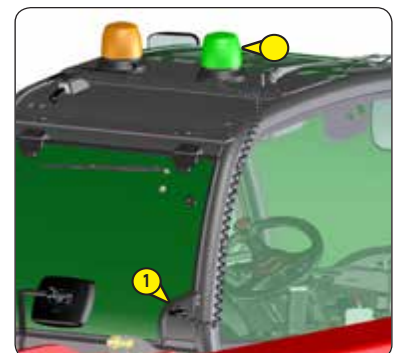

### 15 - REAR CAMERA



### 16 - ENGINE SPEED REGULATOR

**⚠ IMPORTANT ⚠**

*The engine speed regulator cannot under any circumstances be used while driving on the road.*

#### OPERATION

- Turn button 1 to increase or reduce the engine speed, and thus control the hydraulic flow within the attachment circuit.
- View the rev. counter to adjust the engine speed.
- Return the engine to idle before switching off the lift truck's ignition.



### 17 - BOOM ELECTRICAL PREDISPOSITION

Enables an electrical function to be used at the boom head.

#### ATTACHMENT LINE CONTROL

- Put switch 1 to position A (indicator lamp off).
- Push switch 2 forward or backward.

#### BOOM ELECTRIC FUNCTION CONTROL

- Set switch 1 to position B (indicator lamp on).
- Hold down button 3 and operate button 2 forwards or backwards.

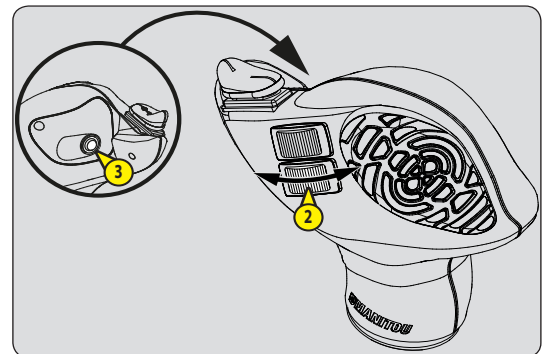

### 18 - ATTACHMENT CIRCUIT WITH QUICK-RELEASE COUPLERS



## 19 - EXTERIOR DRAIN-BACK

Enables connection of a hydraulic attachment for which drain-back is required.



## 20 - ATTACHMENT HYDRAULIC CONTROL FORCED OPERATION

### ⚠ IMPORTANT ⚠

*This OPTION must only be used with an attachment requiring continuous hydraulic movement, such as a brush, feeder bucket, mixer, spray etc. It is strictly forbidden for use in handling operations and all other applications (winch, crane jib, crane jib with winch, hook, etc.).*

*Never leave the driver's cab without resetting the potentiometer C to 0%.  
Before starting the lift truck, make sure that this potentiometer is at 0%.*

### CONTINUOUS HYDRAULIC MOVEMENT OF THE ATTACHMENT

- Check that potentiometer C is set to 0 %.
- Switch button A to the front or the back (depending on the type of attachment), press button B and release button A. The red indicator 1 flashes to indicate that it is in operation.
- Set the required flow rate using potentiometer C.
- To stop continuous hydraulic movement of the attachment, move switch A forwards or backwards or press button B. Indicator 1 goes out.
- Set potentiometer C to 0 %.

NOTE: If the operator leaves the driver's cab, the continuous hydraulic movement will automatically stop and must be restarted.

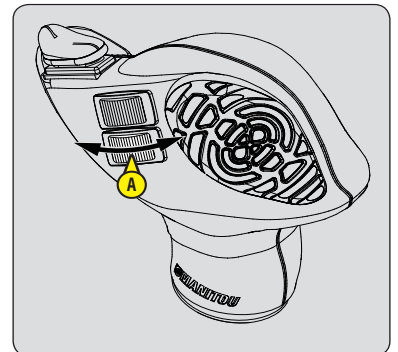

## 21 - BOOM SUSPENSION

MT 733... - MT 933...

The boom suspension dampens shaking of the lift truck on rough ground (e.g. handling straw in a field).

### ⚠ IMPORTANT ⚠

*The boom suspension remains active up to carriage hinge pin lift height of 3.00 m relative to the ground, with the boom retracted.*

*When you exceed this height or when you perform another hydraulic movement (tilt, telescoping, attachment), the boom suspension is momentarily deactivated and the lamp on switch 1 goes out.*

### OPERATION

- Set the forks or attachment down on the ground and raise the front wheels by a few centimetres only.
- Press switch 1 in position A, the indicator lamp comes on indicating that boom suspension is activated.
- Press switch 1 in position B, the indicator lamp goes out indicating that the boom suspension is deactivated.
- When the engine is off, boom suspension is automatically deactivated.





## 22 - ATTACHMENT EASY HYDRAULIC CONNECTION

For easy connection and disconnection of hydraulic attachments.

### OPERATION

- Switch on lift truck ignition.
- Press for two seconds on pushbutton 1 to release the attachment circuit hydraulic pressure.
- Connect or disconnect the quick couplers of the hydraulic attachment (<math>\leq 4</math> - ADAPTABLE ATTACHMENTS AS AN OPTION ON THE RANGE: PICKING UP THE ATTACHMENTS).



## 23 - ATTACHMENT HYDRAULIC LOCKING

Enables the attachment to be locked onto the carriage and a hydraulic attachment to be used by the same hydraulic circuit.

### ⚠ IMPORTANT ⚠

*After locking the attachment, return switch 2 to position A (indicator lamp off) to prevent accidental unlocking of the attachment.*

### ATTACHMENT LOCKING CONTROL

- Put tap 1 in position A and press switch 2 at position B (indicator lamp on).
- Push switch 3 forward to lock the attachment and backward to release it.

### HYDRAULIC ATTACHMENT CONTROL

- Set valve 1 to position B and press switch 2 in position B (indicator lamp on).
- Push switch 3 forward or backward.

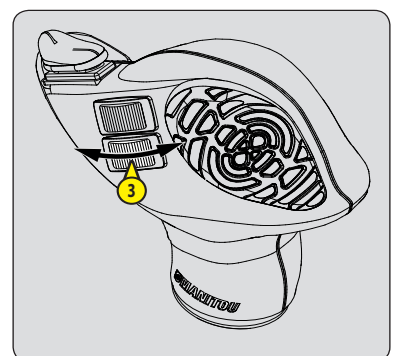
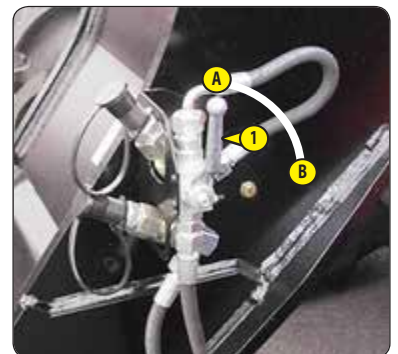



## 24 - BOOM HEAD ELECTROVALVE

Enables use of two hydraulic functions on the attachment circuit.

NOTE: For ease of connection of the quick-release couplers, decompress the hydraulic circuit by pressing button 1 on the electrovalve.

### ATTACHMENT LINE L1 CONTROL

- Put switch 2 to position A (indicator lamp off).
- Push switch 3 forward or backward.

### ATTACHMENT LINE L2 CONTROL

- Set switch 2 to position B (indicator lamp on).
- Hold down button 4 and operate button 3 forwards or backwards.

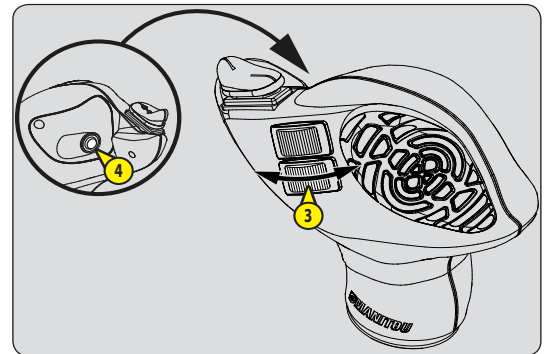
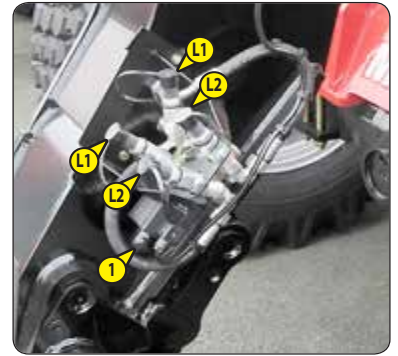

## 25 - BOOM HEAD ELECTROVALVE + HYDRAULIC ATTACHMENT LOCKING

The addition of these two options on the attachment line allows two hydraulic functions to be used and locks the attachment onto the carriage.

### ⚠ IMPORTANT ⚠

To facilitate connection of the quick couplers, decompress the hydraulic circuit by pressing button 1 on the electrovalve. Once the attachment is locked, return valve 4 to position B to prevent accidental release of the attachment.

### ATTACHMENT LINE L1 CONTROL

- Put switch 2 to position A (indicator lamp off).
- Push switch 3 forward or backward.

### ATTACHMENT LINE L2 CONTROL + HYDRAULIC ATTACHMENT LOCKING

#### LOCKING AN ATTACHMENT

- Set valve 4 to position A.
- Set switch 2 to position B (indicator lamp on).
- Hold down button 5 and push button 3 forward to lock the attachment and backward to release it.

#### HYDRAULIC ATTACHMENT

- Set switch 2 to position B (indicator lamp on).
- Hold down button 5 and operate button 3 forwards or backwards.

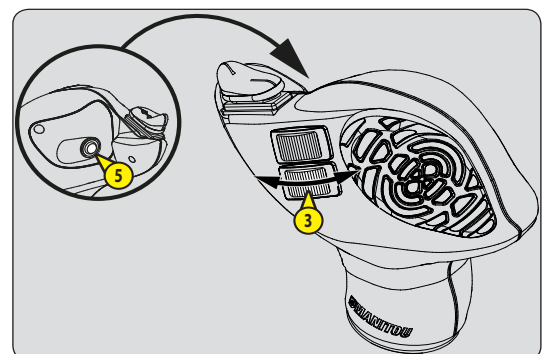
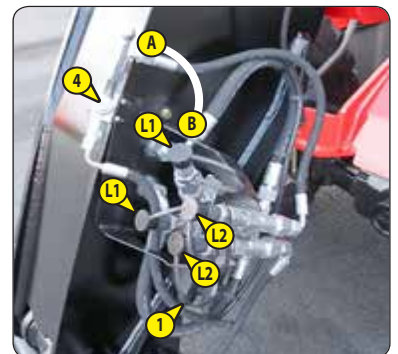

## 26 - LIFTING RING ON SINGLE CARRIAGE

### CONDITIONS OF USE

**⚠ IMPORTANT ⚠**

Follow the instructions given in the instruction manual (↩ 1 - OPERATING AND SAFETY INSTRUCTIONS: INSTRUCTIONS FOR HANDLING LOADS).

The load charts are defined for use without forks and without attachments (↩ SAFETY PLATES AND STICKERS).

- The lifting ring must be used WITHOUT FORKS AND ATTACHMENTS, but the angle of inclination of the carriage must be the same as when the forks are used in the horizontal position.
- Check the maximum permitted angle, which is 45°.
- Do not change the angle of the carriage while using the lifting ring.
- The lifting hook, the chains and slings shall have a minimum capacity of 3000 kg with a safety coefficient of 4 in relation to breakage.

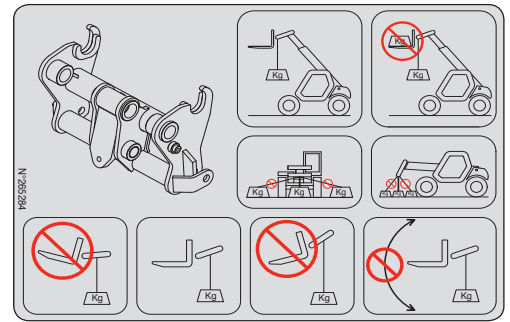



# **3 - MAINTENANCE**



### 3 - MAINTENANCE

<b>ORIGINAL MANITOU SPARE PARTS AND EQUIPMENT</b>	<b>3-3</b>
<b>FORKLIFT TRUCK MAINTENANCE</b>	<b>3-4</b>
<b>DAILY AND WEEKLY MAINTENANCE</b>	<b>3-4</b>
<b>MANDATORY FIRST 500 HOURS OR 6 MONTHS SERVICE</b>	<b>3-5</b>
<b>PERIODIC SERVICE</b>	<b>3-6</b>
<b>OCCASIONAL MAINTENANCE AND OPERATION</b>	<b>3-8</b>
<b>FILTERING ELEMENTS AND BELTS</b>	<b>3-9</b>
<b>LUBRICANTS AND FUEL</b>	<b>3-10</b>
<b>➔ 10H - DAILY SERVICE OR EVERY 10 HOURS OF SERVICE</b>	<b>3-12</b>
<b>➔ 50H - WEEKLY SERVICE OR EVERY 50 HOURS OF SERVICE</b>	<b>3-16</b>
<b>➔ ① 250H - PERIODIC SERVICE - EVERY 250 HOURS OF SERVICE</b>	<b>3-22</b>
<b>➔ ② 500H - PERIODIC SERVICE - EVERY 500 HOURS OF SERVICE OR 1 YEAR</b>	<b>3-24</b>
<b>➔ ③ 1000H - PERIODIC SERVICE - EVERY 1,000 HOURS OF SERVICE OR 2 YEARS</b>	<b>3-28</b>
<b>➔ ④ 2000H - PERIODIC SERVICE - EVERY 2,000 HOURS OF SERVICE OR 4 YEARS</b>	<b>3-34</b>
<b>➔ OCCASIONAL MAINTENANCE</b>	<b>3-38</b>
<b>➔ OCCASIONAL OPERATION</b>	<b>3-42</b>



## ORIGINAL MANITOU SPARE PARTS AND EQUIPMENT

OUR LIFT TRUCKS MUST BE SERVICED USING ORIGINAL MANITOU PARTS.

### BY ALLOWING THE USE OF NON ORIGINAL MANITOU PARTS, YOU RISK:

#### **⚠ IMPORTANT ⚠**

**THE USE OF COUNTERFEIT PARTS OR COMPONENTS NOT APPROVED BY THE MANUFACTURER, MEANS YOU LOSE THE BENEFIT OF THE CONTRACTUAL GUARANTEE.**

- Legally - to be held responsible in the event of an accident.
- Technically - to cause operating malfunctions or shorten the life of the lift truck.

### BY USING ORIGINAL MANITOU PARTS FOR MAINTENANCE OPERATIONS, YOU BENEFIT FROM OUR KNOW-HOW

Through its network, MANITOU provides the user with,

- Know-how and competence.
- The guarantee of high-quality work.
- Original replacement parts.
- Help with preventive maintenance.
- Efficient help with diagnosis.
- Improvements due to experience feedback.
- Operator training.
- Only the MANITOU network has detailed knowledge of the design of the lift truck and therefore the best technical ability to provide maintenance.

#### **⚠ IMPORTANT ⚠**

**ORIGINAL REPLACEMENT PARTS ARE DISTRIBUTED EXCLUSIVELY BY MANITOU AND ITS DEALER NETWORK.**

*The dealer network list is available on the MANITOU web site: [www.manitou.com](http://www.manitou.com)*



## FORKLIFT TRUCK MAINTENANCE

### DAILY AND WEEKLY MAINTENANCE

**⚠ IMPORTANT ⚠**

**THE OPERATOR IS AUTHORISED TO CARRY OUT THIS MAINTENANCE.**

These maintenance operations enable the operator to maintain the lift truck in a clean and safe condition.

### MANDATORY FIRST 500 HOURS OR 6 MONTHS SERVICE

**⚠ IMPORTANT ⚠**

**THIS SERVICE MUST BE CARRIED OUT AFTER THE FIRST 500 HOURS OF SERVICE OR WITHIN THE 6 MONTHS FOLLOWING PUTTING THE MACHINE INTO SERVICE (WHICHEVER OCCURS FIRST).**

### PERIODIC SERVICE

**⚠ IMPORTANT ⚠**

**THE PERIODIC MAINTENANCE MUST BE CARRIED OUT BY AN APPROVED PROFESSIONAL FROM THE MANITOU NETWORK.**

### MAINTENANCE SCHEDULE

This schedule enables the operator to keep up with the periodic service of the lift truck by notifying the total number of hours of operation and the date of the service performed by the professional approved by the MANITOU network.

### OCCASIONAL MAINTENANCE AND OPERATION

These maintenance tasks and operations are to be performed as required for the safety and upkeep of the lift truck.

## DAILY AND WEEKLY MAINTENANCE

### 🔄 10H - DAILY SERVICE OR EVERY 10 HOURS OF SERVICE

- CHECK	Lift truck environment .....	3-12
- CHECK	Engine oil level.....	3-12
- CHECK	Cooling liquid level .....	3-12
- CHECK	Fuel pre-filter .....	3-13
- CHECK	Longitudinal stability limiter and warning device.....	3-13
- CLEAN	Cyclonic pre-filter.....	3-14

### 🔄 50H - WEEKLY SERVICE OR EVERY 50 HOURS OF SERVICE

- CHECK	Gear box oil level.....	3-16
- CHECK	Tyre pressures .....	3-16
- CHECK	Wheel nut tightening .....	3-16
- CHECK	Front axle differential seal .....	3-16
- CHECK	Rear axle differential seal .....	3-16
- CHECK	Front wheel reducer seals .....	3-16
- CHECK	Rear wheel reducer seals .....	3-16
- CHECK	Brake fluid level.....	3-17
- CHECK	Boom pad slide pathways .....	3-17
- CHECK	Hydraulic oil level .....	3-18
- CHECK	Windscreen washer liquid level.....	3-18
- CLEAN	Radiator cores .....	3-18
- CLEAN	Dry air filter cartridge .....	3-19
- CLEAN	Condenser harness (Air conditioning OPTION) .....	3-19
- LUBRICATE	General lubrication .....	3-20



## MANDATORY FIRST 500 HOURS OR 6 MONTHS SERVICE

### FIRST 500 HOURS BEFORE THE FIRST 6 MONTHS

- If the lift truck has reached the first 500 hours of service before the first 6 months have expired, perform both the mandatory service and periodic 500 H service (◀ ➡ ① 500H - PERIODIC SERVICE - EVERY 500 HOURS OF SERVICE OR 1 YEAR).

### FIRST 6 MONTHS BEFORE THE FIRST 500 HOURS

- If the lift truck has not completed 500 hours of service in the first 6 months, just carry out the mandatory service.

## MANDATORY SERVICE

- CHECK	Gear box oil level .....	3-16
- CHECK	Tyre pressures .....	3-16
- CHECK	Wheel nut tightening .....	3-16
- CHECK	Front axle differential seal .....	3-16
- CHECK	Rear axle differential seal .....	3-16
- CHECK	Front wheel reducer seals .....	3-16
- CHECK	Rear wheel reducer seals .....	3-16
- CHECK	Brake fluid level .....	3-17
- CHECK	Boom pad slide pathways .....	3-17
- CHECK	Hydraulic oil level .....	3-18
- CHECK	Windscreen washer liquid level .....	3-18
- CLEAN	Radiator cores .....	3-18
- CLEAN	Dry air filter cartridge .....	3-19
- CLEAN	Condenser harness (Air conditioning OPTION) .....	3-19
- LUBRICATE	General lubrication .....	3-20
- CHECK	Angle gear box oil level .....	3-22
- CHECK	Parking brake .....	3-22
- CLEAN	Heating block check valve .....	3-22
- CHECK	Countdown before "stationary lift truck" exhaust regeneration .....	3-24
- CHECK	Alternator belt tension .....	3-24
- CHECK	Hydraulic oil .....	3-24
- LUBRICATE	Parking brake lever mechanism .....	3-25
- CHECK	Fork wear * .....	3-27
- CHECK	Seat belt .....	3-28
- CLEAN	Fuel tank .....	3-28
- CHECK	Engine silent blocks * .....	3-33
- CHECK	Valve lash * .....	3-33
- CHECK	Gearbox silent blocks * .....	3-33
- CHECK	Gear box controls * .....	3-33
- CHECK	Brake system pressure * .....	3-33
- CHECK	Boom pad wear * .....	3-33
- CHECK	Condition of wiring harnesses and cables * .....	3-33
- CHECK	Lights and signals * .....	3-33
- CHECK	Warning indicators * .....	3-33
- CHECK	Condition of the rear-view mirrors * .....	3-33
- CHECK	Cabin structure * .....	3-33
- CHECK	Frame structure * .....	3-33
- CHECK	Attachment carriage * .....	3-33
- CHECK	Condition of attachments * .....	3-33

*\* Consult your dealer.*



**PERIODIC SERVICE**

**MAINTENANCE SCHEDULE**

		↕ OR ↕				
WHEN DUE ➡	250 H	FIRST 6 MONTHS	FIRST 500 HOURS	500 H or 1 YEAR	750 H	1000 H or 2 YEARS
PERIODIC SERVICE ➡	①	MANDATORY SERVICE	MANDATORY SERVICE + ②	① + ②	①	① + ② + ③
MACHINE COUNTER ➡						
DATE OF SERVICING ➡						

WHEN DUE ➡	1250 H	1500 H or 3 YEARS	1750 H	2000 H or 4 YEARS	2250 H	2500 H or 5 YEARS	2750 H
PERIODIC SERVICE ➡	①	① + ②	①	① + ② + ③ + ④	①	① + ②	①
MACHINE COUNTER ➡							
DATE OF SERVICING ➡							

WHEN DUE ➡	3000 H or 6 YEARS	3250 H	3500 H or 7 YEARS	3750 H	4000 H or 8 YEARS	4250 H	4500 H or 9 YEARS
PERIODIC SERVICE ➡	① + ② + ③	①	① + ②	①	① + ② + ③ + ④	①	① + ②
MACHINE COUNTER ➡							
DATE OF SERVICING ➡							

WHEN DUE ➡	4750 H	5000 H or 10 YEARS	5250 H	5500 H or 11 YEARS	5750 H	6000 H or 12 YEARS	6250 H
PERIODIC SERVICE ➡	①	① + ② + ③	①	① + ②	①	① + ② + ③ + ④	①
MACHINE COUNTER ➡							
DATE OF SERVICING ➡							

➡ ① **250H - PERIODIC SERVICE - EVERY 250 HOURS OF SERVICE**

- CHECK Angle gear box oil level ..... 3-22
- CHECK Parking brake ..... 3-22
- CLEAN Heating block check valve ..... 3-22



**➔ ② 500H - PERIODIC SERVICE - EVERY 500 HOURS OF SERVICE OR 1 YEAR**

- CHECK	Countdown before "stationary lift truck" exhaust regeneration.....	3-24
- CHECK	Alternator belt tension .....	3-24
- CHECK	Hydraulic oil .....	3-24
- LUBRICATE	Parking brake lever mechanism .....	3-25
- REPLACE	Engine oil .....	3-25
- REPLACE	Engine oil filter.....	3-25
- REPLACE	Gear box oil filter.....	3-26
- REPLACE	Front axle differential oil .....	3-26
- REPLACE	Rear axle differential oil .....	3-26
- REPLACE	Hydraulic return oil filter cartridge.....	3-26
- REPLACE	Cabin fan filters .....	3-27
- CHECK	Fork wear * .....	3-27

*\* Consult your dealer.*

**➔ ③ 1000H - PERIODIC SERVICE - EVERY 1,000 HOURS OF SERVICE OR 2 YEARS**

**ALSO PERFORM THE 500 HOUR PERIODIC MAINTENANCE OPERATIONS.**

- CHECK	Seat belt .....	3-28
- CLEAN	Fuel tank .....	3-28
- REPLACE	Fuel tank breather .....	3-28
- REPLACE	Coolant.....	3-28
- REPLACE	Dry air filter cartridge .....	3-29
- REPLACE	Fuel pre-filter .....	3-30
- REPLACE	Fuel filter .....	3-30
- REPLACE	Alternator belt .....	3-30
- REPLACE	Gearbox oil .....	3-31
- CLEAN	Gearbox sump strainer .....	3-31
- REPLACE	Angle gear box oil .....	3-32
- REPLACE	Front wheel reducer oil.....	3-32
- REPLACE	Rear wheel reducer oil .....	3-32
- CHECK	Engine silent blocks * .....	3-33
- CHECK	Valve lash * .....	3-33
- CHECK	Gearbox silent blocks * .....	3-33
- CHECK	Gear box controls * .....	3-33
- CHECK	Brake system pressure * .....	3-33
- CHECK	Boom pad wear * .....	3-33
- CHECK	Condition of wiring harnesses and cables * .....	3-33
- CHECK	Lights and signals * .....	3-33
- CHECK	Warning indicators * .....	3-33
- CHECK	Condition of the rear-view mirrors * .....	3-33
- CHECK	Cabin structure * .....	3-33
- CHECK	Frame structure * .....	3-33
- CHECK	Attachment carriage * .....	3-33
- CHECK	Condition of attachments * .....	3-33
- REPLACE	Brake fluid * .....	3-33
- BLEED	Brake circuit * .....	3-33
- ADJUST	Brake * .....	3-33

*\* Consult your dealer.*



**➔ 4 2000H - PERIODIC SERVICE - EVERY 2,000 HOURS OF SERVICE OR 4 YEARS**

**ALSO PERFORM THE 500 HOUR AND 1,000 HOUR PERIODIC MAINTENANCE OPERATIONS.**

- CHECK	Wheel nut tightening torques .....	3-34
- CLEAN	Air conditioning (OPTION) * .....	3-34
		<b>* Consult your dealer.</b>
- REPLACE	Dry air filter safety cartridge .....	3-34
- REPLACE	Hydraulic oil .....	3-35
- CLEAN	Hydraulic oil tank suction strainer .....	3-35
- REPLACE	Hydraulic oil tank filter cap .....	3-35
- REPLACE	Distributor control head filter .....	3-35
- CHECK	Radiator * .....	3-36
- CHECK	Water pump and thermostat * .....	3-36
- CHECK	Alternator and starter * .....	3-36
- CHECK	Turbocharger * .....	3-36
- CHECK	Transmission pressures * .....	3-36
- CHECK	Steering * .....	3-36
- CHECK	Steering swivel joints * .....	3-36
- CHECK	Brake pad and brake disk wear * .....	3-36
- CHECK	Condition of boom assembly * .....	3-36
- CHECK	Bearings and bushings of the boom * .....	3-36
- CHECK	Condition of hoses and flexible pipes * .....	3-36
- CHECK	Condition of cylinders (leakage, rods) * .....	3-36
- CHECK	Hydraulic circuit pressures * .....	3-36
- CHECK	Bearings and bushings of the frame* .....	3-36
- REPLACE	Compressor belt (Air Conditioning OPTION) * .....	3-36
		<b>* Consult your dealer.</b>

**OCCASIONAL MAINTENANCE AND OPERATION**

**➔ OCCASIONAL MAINTENANCE**

- CLEAN	"Stationary lift truck" exhaust regeneration .....	3-38
- REPLACE	Wheels .....	3-38
- REPLACE	Battery .....	3-39
- ADJUST	Front headlights .....	3-39
- RESET	Longitudinal stability limiter and warning device .....	3-40

**➔ OCCASIONAL OPERATION**

- TOW OR WINCH	Lift truck .....	3-42
- SLING	Lift truck .....	3-42
- TRANSPORT	Lift truck .....	3-43



## FILTERING ELEMENTS AND BELTS

### ➔ 2 500H - PERIODIC SERVICE - EVERY 500 HOURS OF SERVICE OR 1 YEAR

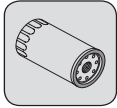

ENGINE OIL FILTER  
Part No.: 943326

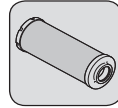

HYDRAULIC RETURN OIL FILTER CARTRIDGE  
Part No.: 236095

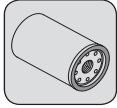

GEAR BOX OIL FILTER  
Part No.: 561749

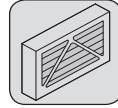

CAB FAN FILTER  
Part No.: 282619

### ➔ 3 1000H - PERIODIC SERVICE - EVERY 1,000 HOURS OF SERVICE OR 2 YEARS

*ALSO ADD FILTER CARTRIDGES FOR PERIODIC MAINTENANCE AFTER 500 HOURS OF SERVICE.*



DRY AIR FILTER CARTRIDGE  
Part No.: 563416



FUEL TANK BREATHER  
Part No.: 266219

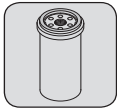

FUEL FILTER  
Part No.: 799967

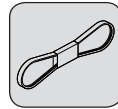

ALTERNATOR BELT  
Part No.: 941243

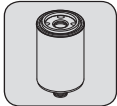

FUEL PRE-FILTER  
Part No.: 799968

### ➔ 4 2000H - PERIODIC SERVICE - EVERY 2,000 HOURS OF SERVICE OR 4 YEARS

*ALSO ADD FILTER CARTRIDGES FOR PERIODIC MAINTENANCE AT 500 HOURS AND 1,000 HOURS OF SERVICE.*

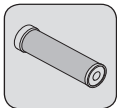

SAFETY DRY AIR FILTER CARTRIDGE  
Part No.: 563415

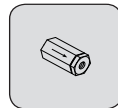

DISTRIBUTOR CONTROL HEAD FILTER  
Part No.: 254780



FILTER CAP FOR HYDRAULIC FLUID TANK  
Part No.: 62415

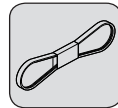

COMPRESSOR BELT  
(AIR CONDITIONING OPTION)  
Part No.: 319790

### ➔ OCCASIONAL MAINTENANCE

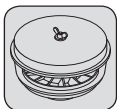

CYCLONIC PRE-FILTER  
Part No.: 224713

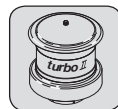

TURBO 2 SELF-CLEANING PRE-FILTER (OPTION)  
Part No.: 266360

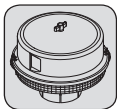

AUTOMATIC VACUUM-CLEANING PRE-FILTER  
(OPTION)  
Part No.: 226611

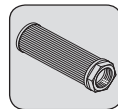

SUCTION STRAINER FOR HYDRAULIC OIL TANK  
Part No.: 224726



## LUBRICANTS AND FUEL

### ⚠ IMPORTANT ⚠

- USE THE RECOMMENDED LUBRICANTS AND FUEL:**
- For topping up, oils may not be miscible.
  - For oil changes, MANITOU oils are perfectly appropriate.

### DIAGNOSTIC ANALYSIS OF OILS

If a service or maintenance contract has been set up with the dealer, a diagnostic analysis of engine, transmission and axle oils may be requested depending on the rate of use.

### (\*) REQUIRED FUEL SPECIFICATION

Use a high-quality fuel to obtain optimal performance of the engine.

- EN590 diesel fuel (sulphur content < 10 ppm)
- ASTM D975 diesel fuel (sulphur content < 15 ppm)

### RECOMMENDATION

ENGINE		RECOMMENDATION											
DESCRIPTION	CAPACITY	-40 °C	-30	-20	-10	0	+10	+20	+30	+40	+50 °C		
ENGINE	9 ℓ												
COOLING CIRCUIT	21 ℓ												
FUEL TANK	120 ℓ												
TRANSMISSION		RECOMMENDATION											
DESCRIPTION	CAPACITY	-40 °C	-30	-20	-10	0	+10	+20	+30	+40	+50 °C		
GEARBOX	16,6 ℓ												
ANGLE GEAR BOX	2,2 ℓ												
FRONT AXLE		RECOMMENDATION											
DESCRIPTION	CAPACITY	-40 °C	-30	-20	-10	0	+10	+20	+30	+40	+50 °C		
FRONT AXLE DIFFERENTIAL	8,1 ℓ												
FRONT WHEEL REDUCING GEAR	2 x 0,8 ℓ												
FRONT WHEEL REDUCING GEAR PIVOTS													
REAR AXLE		RECOMMENDATION											
DESCRIPTION	CAPACITY	-40 °C	-30	-20	-10	0	+10	+20	+30	+40	+50 °C		
REAR AXLE DIFFERENTIAL	8,1 ℓ												
REAR WHEEL REDUCING GEAR	2 x 0,8 ℓ												
REAR WHEEL REDUCING GEAR PIVOTS													
REAR AXLE OSCILLATION													



➔ **10H - DAILY SERVICE OR EVERY 10 HOURS OF SERVICE**

**CHECK**

**Lift truck environment**

Carry out a general inspection around the lift truck:

- Fluid leaks or stains on the ground.
- Additional objects on the lift truck and in the cabin.
- Mounting and locking of the attachment.
- Mounting and adjustment of rear-view mirrors.
- Condition of the tyres to detect cuts, blisters, wear, etc.

**⚠ IMPORTANT ⚠**

Follow the operator instructions (↩ 1 - OPERATING AND SAFETY INSTRUCTIONS: OPERATOR INSTRUCTIONS).

**CLEANLINESS OF THE FORKLIFT**

- Cleanliness of lights and rear-view mirror.
- Excess dirt or build-up of material (e.g. straw, flour, sawdust, organic waste, etc.).
- On a daily basis, according to the conditions of use and the environment, the operator should ensure that the forklift truck is kept in a clean condition.
- Particular attention should be paid to accumulations of flammable materials (e.g. straw, flour, sawdust, organic waste, etc.) and fuel or lubricant leaks, as these significantly increase the risk of fire outbreaks.
- A regular inspection of the whole lift truck, especially the engine housing and the central part of the frame, is necessary to see how frequently it needs to be cleaned to prevent these potential accumulations of material or leakages.

**CHECK**

**Engine oil level**

Place the lift truck on level ground with the engine stopped, and let the oil settle in the sump.

- Open the engine cover.
- Pull out dipstick 1.
- Clean the dipstick and check the correct level between the two notches.
- If necessary, add oil (↩ LUBRICANTS AND FUEL) through the filler hole 2.
- Visually check that there is no leakage or seepage.



**CHECK**

**Cooling liquid level**

Place the lift truck on level ground with the engine stopped, and allow the engine to cool.

**⚠ IMPORTANT ⚠**

To avoid any risk of spraying or scalding, wait until the engine has cooled down before removing the cooling system filler plug.

In the event of an emergency, it is possible to use water as the coolant, but then proceed to drain the coolant circuit as quickly as possible.

- Open the engine cover.
- The liquid must be at the MAX. level on the expansion tank 1.
- If necessary, add coolant (↩ LUBRICANTS AND FUEL) through the filler hole 2.
- Visually check that there is no leakage or seepage.



CHECK

Fuel pre-filter

**⚠ IMPORTANT ⚠**

Carefully clean the outside of the pre-filter and its holder, to prevent dust from getting into the system.

- Open the engine cover.
- Disconnect electrical wiring harness 1 from the fuel pre-filter.
- Place a hose on the drain plug 2 and the other end in a container.
- Unscrew the drain plug 2 by two turns.
- Allow the diesel fuel to flow out until it is free from impurities and water.
- Retighten drain plug 2 and reconnect the wiring harness 1.



CHECK

Longitudinal stability limiter and warning device









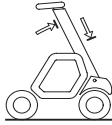

**⚠ IMPORTANT ⚠**

Use the test button  only when instructed, following the guidance for a short press (less than 1 second) or a long press (5 seconds).

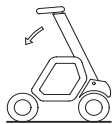
In case of doubt during the test procedure, exit cleanly by a short press on the "BUCKET" MODE  or "SUSPENDED LOAD" buttons .

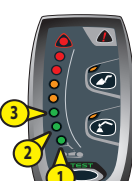
These tests are essential for checking the correct operation and adjustment of the different components of the device.

- Place the lift truck on flat, level ground with the wheels straight.
- Hold down the test button .

<p>STAGE 1 ↓</p>	 <ul style="list-style-type: none"> <li>- An audible signal.</li> <li>- First green LED flashing.</li> <li>- Test button lit.</li> </ul>	<p>⇒</p>  <ul style="list-style-type: none"> <li>- Place the lift truck without any attachment, with the boom fully retracted and raised.</li> </ul>	<p>⇒</p> <p>Short press the test button. </p> <p>⇒</p> <p><b>TEST OK</b></p> <ul style="list-style-type: none"> <li>- An audible signal and go to stage 2.</li> </ul> <p><b>TEST NOT OK</b></p> <ul style="list-style-type: none"> <li>- Two audible signals and fault indicator lamp  lit.</li> <li>- Exit test mode.</li> <li>- Go to stage 4.</li> </ul>
<p>STAGE 2 ↓</p>	 <ul style="list-style-type: none"> <li>- First green LED continuously lit.</li> <li>- Second green LED flashing.</li> <li>- Test button lit.</li> </ul>	<p>⇒</p>  <ul style="list-style-type: none"> <li>- Lower the boom with the engine running at full revs and the hydraulic control at the maximum setting. Slow lowering until movement is cut off.</li> </ul>	<p>⇒</p> <p>Short press the test button. </p> <p>⇒</p> <p><b>TEST OK</b></p> <ul style="list-style-type: none"> <li>- An audible signal and go to stage 3.</li> </ul> <p><b>TEST NOT OK</b></p> <ul style="list-style-type: none"> <li>- Two audible signals and fault indicator lamp  lit.</li> <li>- Exit test mode.</li> <li>- Go to stage 4.</li> </ul>
<p>STAGE 3 ↓</p>	 <ul style="list-style-type: none"> <li>- First and second green LEDs continuously lit.</li> <li>- Third green LED flashing.</li> <li>- Test button lit.</li> </ul>	<p>⇒</p> <ul style="list-style-type: none"> <li>- Lower the boom until the movement is cut off.</li> <li>- Request, in the following order: an excavation, dumping and a telescope boom extension. None of these 3 movements should be possible.</li> </ul>	<p>⇒</p> <p>Short press the test button. </p> <p>⇒</p> <p><b>TEST OK</b></p> <ul style="list-style-type: none"> <li>- Conformity of aggravating movement cut-off.</li> <li>- Exit test mode. All the LEDs will light for 2 seconds and an audible signal will be sounded.</li> </ul> <p><b>TEST NOT OK</b></p> <ul style="list-style-type: none"> <li>- Fault indicator lamp  comes on.</li> <li>- Exit test mode.</li> <li>- Go to stage 4.</li> </ul>
<p>STAGE 4</p>	 <ul style="list-style-type: none"> <li>- The fault warning light remains permanently on until the error is repaired.</li> </ul>	<p>⇒</p> <ul style="list-style-type: none"> <li>- The  warning indicator and an audible signal indicate a fault.</li> <li>- Consult the screen for the fault code.</li> </ul> <p>NOTE: A faulty fuse can generate several error codes. If this is the case, check the fuses.</p> <ul style="list-style-type: none"> <li>- If error codes 520499, 520742, 520743 or 520754 are displayed, resetting the longitudinal stability limiter and warning device may solve the problem (⚠ OCCASIONAL MAINTENANCE).</li> </ul> <p>NOTE: For the stage 3 test, specify the non-conforming aggravating hydraulic movements, if necessary.</p>	

## CLEAN

## Cyclonic pre-filter

The cleaning interval is given as a guide, however the pre-filter must be emptied and cleaned as soon as impurities reach the MAX level on the tank.

### **⚠ IMPORTANT ⚠**

*When cleaning, take care not to let impurities into the dry air filter.*

- Loosen nut 1 remove cover 2 and empty the tank.
- Clean the pre-filter unit with a clean dry cloth and reassemble the unit.





➔ **50H - WEEKLY SERVICE OR EVERY 50 HOURS OF SERVICE**

**CHECK**

**Gear box oil level**

Park the lift truck on level ground with the boom raised, the engine stopped. Carry out the check within 5 minutes of the engine being stopped.

**⚠ IMPORTANT ⚠**

**Raise the boom and place the boom safety wedge on the rod of the lifting cylinder (↖ 1 - INSTRUCTIONS AND SAFETY RECOMMENDATIONS: LIFT TRUCK MAINTENANCE INSTRUCTIONS).**

- Remove the plastic cap 1.
- Pull out dipstick 2.
- Wipe the dipstick and check the correct level between the two MIN and MAX marks.
- If necessary, add oil (↖ 1000H: REPLACE Gear box oil).
- Visually check that there is no leakage or seepage.



**CHECK**

**Tyre pressures**

**CHECK**

**Wheel nut tightening**

**⚠ IMPORTANT ⚠**

**Check that the air hose is correctly connected to the tyre valve before inflating and keep all persons at a distance during inflation. Follow the recommended tyre pressures.**

- Check the wheel nut tightening. Non-compliance with this instruction can lead to deterioration and breakage of the wheel bolts and distortion of the wheels.
- Check and restore tyre pressures if necessary (↖ 2 - DESCRIPTION: TYRES).

NOTE: There is an OPTIONAL wheel tool kit.

**CHECK**

**Front axle differential seal**

**CHECK**

**Rear axle differential seal**

Place the lift truck on level ground with the engine stopped.

- Visually check that there is no leakage or seepage.
- If there is any leakage or seepage, check the level:
  - Remove the level plug 1, the oil should be flush with the edge of the hole.
  - If necessary, add oil (↖ LUBRICANTS AND FUEL) through the filler hole 2.
  - Refit and tighten the level plug (tightening torque 34 - 49 N.m).

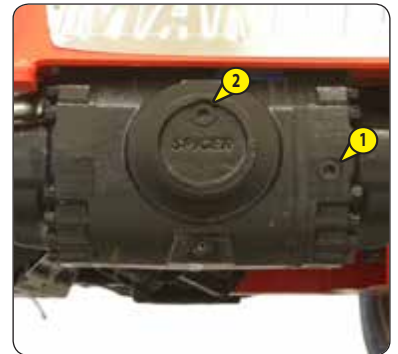

**CHECK**

**Front wheel reducer seals**

**CHECK**

**Rear wheel reducer seals**

Place the lift truck on level ground with the engine stopped.

- Visually check that there is no leakage or seepage.
- If there is any leakage or seepage, check the level:
  - Place level plug 1 in a horizontal position.
  - Remove the level plug; the oil should be flush with the edge of the opening.
  - If necessary, add oil (↖ LUBRICANTS AND FUEL) by the same hole.
  - Refit and tighten the level plug (tightening torque 34 - 49 N.m).

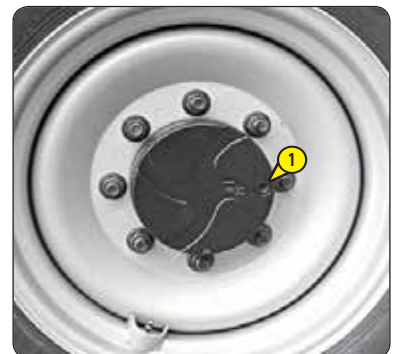

**CHECK**

**Brake fluid level**

Place the lift truck on level ground.

**⚠ IMPORTANT ⚠**

*If the brake oil level is abnormal consult your dealer.*

- Loosen screw 1 and lift up the brake fluid and windscreen washer tank access panel 2.
- Check tank 3. The correct level should be at the MAX. level on the tank.
- Visually check that there is no leakage or seepage.
- If necessary, add oil (↔ LUBRICANTS AND FUEL).
- Pivot the tank 3 to access filler cap 4.
- Remove the cap 4.
- Add oil through filler port.
- Refit the cap.



**CHECK**

**Boom pad slide pathways**

To preserve optimum operation, the pad slide pathways should be correctly lubricated:

**⚠ IMPORTANT ⚠**

**MANDATORY GREASING OF THE BOOM AFTER:**

*Cleaning the boom, especially after using high pressure cleaner.*

*The forklift has been unused for a long period of time.*

- Fully extend the boom.
- Check the condition of the surface of the pad slide pathways, surface run in (steel whitened) without traces of corrosion.
- If necessary lubricate the pad slide pathways (↔ LUBRICANTS AND FUEL).
- Telescope the boom several times in order to spread the lubricant evenly.
- Remove the surplus lubricant.



**⚠ IMPORTANT ⚠**

*If the lift truck is used in an abrasive environment (dust, sand, coal) use lubricating varnish (MANITOU Part No.: 483536).*

*Consult your dealer.*

**CHECK**

**Hydraulic oil level**

Place the lift truck on level ground with the engine stopped, and the boom retracted and lowered as far as possible.

**⚠ IMPORTANT ⚠**

*Use a clean funnel and clean the underside of the oil drum before filling.*

- Check dipstick 1, the correct level must be at the level of the red dot.
- If necessary, add oil (<math>\leq</math> LUBRICANTS AND FUEL).
- Remove the cap 2.
- Add oil through filler port 2.
- Refit the cap.
- Visually check that there is no leakage or seepage.



**CHECK**

**Windscreen washer liquid level**

Place the lift truck on level ground.

- Loosen screw 1 and lift up the brake fluid and windscreen washer tank access panel 2.
- Visually check the level in the tank.
- If necessary add windscreen washer fluid (<math>\leq</math> LUBRICANTS AND FUEL).
- Remove the cap 3.
- Add windscreen washer liquid through filler port.
- Refit the cap.



**CLEAN**

**Radiator cores**

**⚠ IMPORTANT ⚠**

*In a polluting atmosphere, clean the radiator cores every day.*

*Do not use a water jet or high pressure steam as this could damage the fins.*

- Open the engine cover.
- If necessary, clean the intake grille on the engine bonnet.
- Using a soft cloth, clean the radiator cores in order to remove as much dirt as possible.
- Clean the radiator using a compressed air jet aimed from the engine towards the radiator, in the opposite direction to the cooling air flow.



**CLEAN**

**Dry air filter cartridge**

When used in very dusty atmospheres there are pre-filtration elements (◀ FILTER CARTRIDGES AND BELTS). The cartridge checking and cleaning interval must also be reduced.

**⚠ IMPORTANT ⚠**

*If the clogging indicator light comes on, this operation should be performed as soon as possible (maximum 1 hour).*

*Never operate the lift truck with the air filter removed or damaged.*

*Maintain a safety distance of 30 mm between the jet of air and the cartridge to avoid tearing or piercing the cartridge.*

*The cartridge must not be blown through close to the air filter casing.*

*Never clean the cartridge by tapping it on a hard surface.*

*Protect your eyes during this operation.*

*Never wash a dry air filter cartridge.*

*Never clean the safety cartridge located inside the filter cartridge. Change it for a new one if it is clogged or damaged.*

- For the dismantling and refitting of the cartridge (◀ 1000H: REPLACE Air filter cartridge).
- Clean the filter cartridge using a compressed air jet (max. pressure 3 bars) directed from the top to the bottom and from the inside towards the outside at a minimum distance of 30 mm from the cartridge wall.
- Cleaning is completed when there is no more dust on the cartridge.
- Clean the cartridge seal surface with a damp, clean lint-free cloth and grease with a silicone lubricant (MANITOU part no.: 479292).
- Check visually the outer condition of the air filter and its mounts. Verify the condition of the hoses and their mounts also.

**CLEAN**

**Condenser harness (Air conditioning OPTION)**

**⚠ IMPORTANT ⚠**

*In a polluting atmosphere, clean the radiator core every day.*

*Do not use a water jet or high-pressure steam as this could damage the condenser fins.*

- Remove the protective grid 1 and clean it if necessary.
- Visually check whether the condenser is clean and clean it if necessary.
- Clean the condenser using a compressed air jet aimed in the same direction as the air flow.
- Clean with the fans running for best results.





**LUBRICATE**

**General lubrication**

To be carried out weekly, if the lift truck has been operated for less than 50 hours during the week.

**⚠ IMPORTANT ⚠**

*In the event of prolonged use in an extremely dusty or oxidising atmosphere, reduce this interval to 10 hours of service or every day.*

Clean, then lubricate the following points with grease (← LUBRICANTS AND FUEL) and remove the surplus.

**BOOM**

- 1 - Lubricators of the boom pin (2 lubricators).
- 2 - Lubricators of the carriage pin (2 lubricators).
- 3 - Lubricator of the tilting cylinder foot pin (1 lubricator).
- 4 - Lubricator of the tilt cylinder head axle (1 lubricator).
- 5 - Lubricator of the lifting cylinder foot pin (1 lubricator).
- 6 - Lubricator of the lifting cylinder head pin (1 lubricator).
- 7 - Lubricator of the compensation cylinder foot pin (1 lubricator).
- 8 - Lubricator of the compensation cylinder head pin(1 lubricator).

**CAB DOOR**

- 9 - Door lubricators (4 lubricators).

**FRONT AND REAR WHEEL REDUCTION GEAR PIVOTS**

- 10 - Lubricators of the wheel reduction gear pivot pins (8 lubricators).

**REAR AXLE OSCILLATION**

- 11 - Rear axle oscillation lubricators (2 lubricators).

**STABILISERS**

MT 1033...

- 12 - Lubricators of the stabiliser cylinder shafts (4 lubricators).
- 13 - Lubricators of the stabiliser shafts (4 lubricators).



OPTION

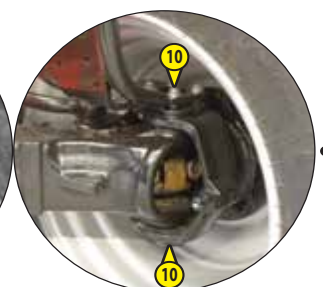



**➔ 250H - PERIODIC SERVICE - EVERY 250 HOURS OF SERVICE**

**CHECK**

**Angle gear box oil level**

Park the lift truck on level ground with the boom raised and the engine stopped.

**⚠ IMPORTANT ⚠**

**Raise the boom and place the boom safety wedge on the rod of the lifting cylinder (⚠ 1 - INSTRUCTIONS AND SAFETY RECOMMENDATIONS: LIFT TRUCK MAINTENANCE INSTRUCTIONS).**

- Pull out dipstick 1.
- Wipe the dipstick and check the correct level between the two MIN and MAX marks.
- If necessary, add oil (⚠ 1000H: REPLACE Angle gear box oil).
- Visually check that there is no leakage or seepage.



**CHECK**

**Parking brake**

Place the lift truck on a slope of at least 15% with the rated load in the transport position.

- Check the tightening adjustment by locking the parking brake in position A.
- The adjustment is correct when the lift truck remains stationary on the slope.
- Adjust if necessary.
- Press the brake pedal, then release the parking brake in position B.
- Progressively tighten the end of the lever 1 and recheck braking.
- Repeat the operation until the correct braking adjustment is obtained.

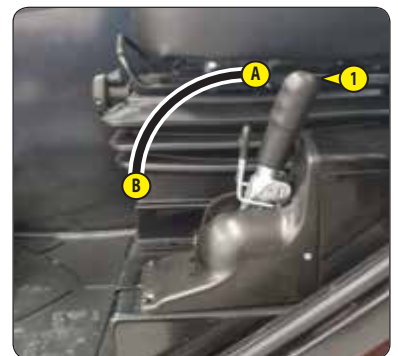

**CLEAN**

**Heating block check valve**

- Since one-way valve 1 is located under the cab, it is possible for it to become obstructed with spattered mud for example. Clean if necessary.





**500H - PERIODIC SERVICE - EVERY 500 HOURS OF SERVICE OR 1 YEAR**

**CHECK Countdown before "stationary lift truck" exhaust regeneration**

Depending on the countdown before the next regeneration, you can evaluate and, if necessary, perform a regeneration during the periodic 500-hour service (3 - MAINTENANCE: OCCASIONAL MAINTENANCE).

- Short press button A to move from one screen to the next until the countdown before next regeneration screen is displayed (700h => 0h).



**CHECK Alternator belt tension**

**⚠ IMPORTANT ⚠**

*If the compressor belt has to be changed, check the tension again after the first 20 hours of operation.*

- Open the engine cover.
- Remove the protective casing 1.
- Check the belt for signs of wear and cracks, and change if necessary (3 - FILTER ELEMENTS AND BELTS).
- Check the belt tension between the crankshaft and alternator pulleys.
- Under a normal pressure exerted with the thumb (45 N), the clearance should be approximately 10 mm.
- Adjust if necessary.
- Loosen the screws 2 and 3 by two to three thread turns.
- Tighten the screw 4 to tighten the belt to the tension required.
- Retighten the screws 2 (tightening torque 30 N.m) and the screw 3 (tightening torque 42 N.m).
- Refit the protective casing 1.

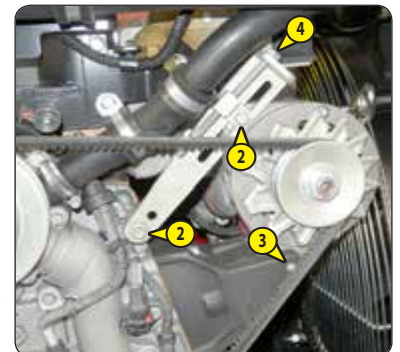

**CHECK Hydraulic oil**

MANITOU offers a hydraulic oil analysis kit which might make it possible to delay the recommended deadline in the periodic maintenance schedule (2,000 hours). In this case we recommend an analysis of the hydraulic oil every 500 hours of service.

The oil analysis kit also makes it possible to confirm the oil quality so as to obtain a deadline of 2000 hours for specific uses causing constraints on the hydraulic circuit: extreme environmental conditions, use of the attachments with a very high hydraulic flow rate (such as a sweeper, or a concrete mixer).

- Order an oil analysis kit from your dealer.
- Upon receiving the kit, take a sample of oil and follow the instructions shown on the kit.
- According to the results, keep the analysis report or replace the hydraulic oil.

**Oil analysis kit (MANITOU Part No.: 958162)**



**LUBRICATE**

**Parking brake lever mechanism**

- Clean and lubricate the pivot pins 1 with grease (← LUBRICANTS AND FUEL).

**REPLACE**

**Engine oil**

**REPLACE**

**Engine oil filter**

Place the lift truck on level ground, let the engine run at idling speed for a few minutes, then stop the engine.

**⚠ IMPORTANT ⚠**

*Dispose of the drain oil in an ecological manner.*

*Tighten the oil filter by hand pressure only and lock the filter in place by a quarter turn.*

**DRAINING THE OIL**

- Open the engine cover.
- Remove access panels 1 and 2.
- NOTE: When removing cover plates and hatches, clean the surrounding area and remove any accumulations of flammable materials.
- Place a container under the drain hole and unscrew the drain plug 3.
- Take drain hose 4.
- Place the end of the drain hose in the container and screw the hose fully to the drain connector 3.
- Remove the filler plug 5 to ensure correct drainage.

**REPLACEMENT OF THE FILTER**

- Unscrew and discard the engine oil filter 6, together with its seal.
- Clean the filter bracket with a clean, lint-free cloth.
- Lightly oil the seal before refitting the new oil filter (← FILTER CARTRIDGES AND BELTS) on its bracket (tightening torque 15 - 17 N.m).

**FILLING WITH OIL**

- Remove, clean and refit drain hose 4.
- Refit and tighten the drain plug 3.
- Fill up with oil (← LUBRICANTS AND FUEL) through filler hole 5.
- Wait a few minutes to allow the oil to flow into the sump.
- Start the engine and let it run for a few minutes.
- Check for possible leaks from the drain plug and the oil filter.
- Stop the engine, wait a few minutes and check the correct level between the two marks on the dipstick 7.
- Top up the level if necessary.
- Refit access panels 1 and 2.

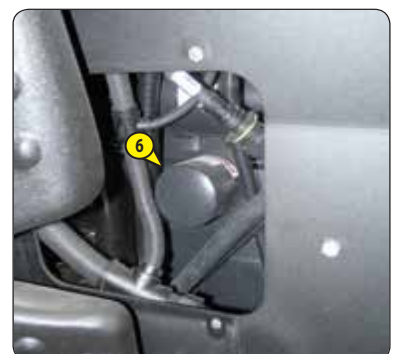
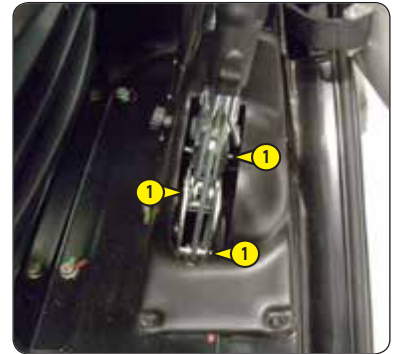

**REPLACE**

**Gear box oil filter**

**⚠ IMPORTANT ⚠**

*Raise the boom and place the boom safety wedge on the rod of the lifting cylinder (⇐ 1 - INSTRUCTIONS AND SAFETY RECOMMENDATIONS: LIFT TRUCK MAINTENANCE INSTRUCTIONS).*

*Tighten the gear box oil filter by hand pressure only and lock the filter in place by a quarter turn.*

- Remove the cover plate 1.

NOTE: When removing cover plates and hatches, clean the surrounding area and remove any accumulations of flammable materials.

- Unscrew and discard gear box oil filter 2.
- Carefully clean the filter head with a clean, lint-free cloth.
- Lightly oil the new seal and fit it to the filter.
- Fill up the new gear box oil filter (⇐ FILTER CARTRIDGES AND BELTS) with oil (⇐ LUBRICANTS AND FUEL).
- Refit the filter, making sure that the seal is correctly positioned and tightened.
- Refit cover plate 1.



**REPLACE**

**Front axle differential oil**

**REPLACE**

**Rear axle differential oil**

Place the lift truck on level ground with the engine stopped and the still warm differential oil.

**⚠ IMPORTANT ⚠**

*Dispose of the drain oil in an ecological manner.*

- Place a container under drain plugs 1 and unscrew them.
- Remove level plug 2 and filling plug 3 to ensure that the oil is drained properly.
- Refit and tighten the drain plugs 1 (tightening torque 34 - 49 N.m).
- Fill up with oil (⇐ LUBRICANTS AND FUEL) through filler hole 3.
- The level is correct when the oil level is flush with the edge of opening 2.
- Check for any possible leaks at the drain plugs.
- Refit and tighten level plug 2 (tightening torque 34 - 49 N.m) and filling plug 3 (tightening torque 34 - 49 N.m).
- Repeat this operation for the rear axle differential.

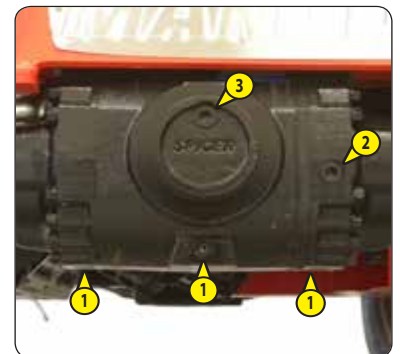

**REPLACE**

**Hydraulic return oil filter cartridge**

Stop the engine and release the pressure from the systems by operating the hydraulic controls.

**⚠ IMPORTANT ⚠**

*Thoroughly clean the outside of the filter and its surroundings before any operation to prevent any risk of polluting the hydraulic system.*

*Tighten the body of the filter by hand pressure only and lock the body of the filter in place by a quarter turn.*

- Place a container under hydraulic return oil filter 1.
- Unscrew the body of the filter.
- Remove the hydraulic return oil filter cartridge and replace with a new one (⇐ FILTER CARTRIDGES AND BELTS).
- Make sure that the cartridge is correctly positioned and refit the body of the filter.
- Wait a few moments while the oil flows into the container.

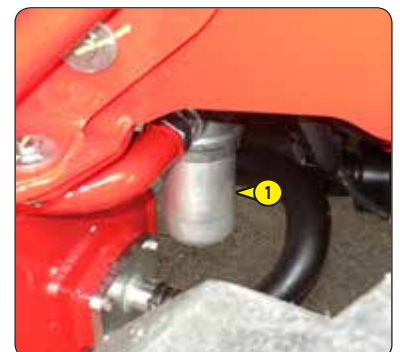

**REPLACE**

- Unscrew thumbscrew 1 and remove protective casing 2.
- Remove the cab ventilation filter 3 and replace it with a new one (◀ FILTER CARTRIDGES AND BELTS).
- Refit the protective casing.

**Cabin fan filters****CHECK****Fork wear \***

*\* Consult your dealer.*

**1000H - PERIODIC SERVICE - EVERY 1,000 HOURS OF SERVICE OR 2 YEARS**

ALSO PERFORM THE 500 HOUR PERIODIC MAINTENANCE OPERATIONS.

**CHECK**

**Seat belt**

**⚠ IMPORTANT ⚠**

*Under no circumstances must the lift truck be used if the seat belt is defective (fixing, locking, cuts, tears, etc.).  
Immediately repair or replace the seat belt.*

**SEAT BELT WITH TWO ANCHORING POINTS**

- Check the following points:
  - Fixing of the anchoring points on the seat.
  - Cleanness of the strap and the locking mechanism.
  - Triggering of the locking mechanism.
  - Condition of the strap (cuts, curled edges).

**REELED SEAT BELT WITH TWO ANCHORING POINTS**

- Check the points listed above together with the following points:
  - The correct winding of the belt.
  - Condition of the reel guards.
  - Roller locking mechanism when the strap is given a sharp tug.

NOTE: After an accident, replace the seat belt.

**CLEAN**

**Fuel tank**

**REPLACE**

**Fuel tank breather**

Place the lift truck on level ground with the engine stopped.

**⚠ IMPORTANT ⚠**

*While carrying out these operations, do not smoke or work near a flame.*

*Never try to carry out a weld or any other operation by yourself, this could provoke an explosion or a fire.*

- Inspect the parts of the fuel circuit and the tank liable to leak, both visually and by touch.
- In the event of a leak, contact your dealer.
- Place a container under drain plug 1 and unscrew the plug.
- Remove the filler plug 2 to ensure correct drainage.
- Rinse with ten litres of clean diesel through filler hole 3.
- Refit and tighten the drain plug 1 (tightening torque 29 - 39 N.m).
- Unscrew the breather 4 and replace with a new one (⇐ FILTER CARTRIDGES AND BELTS) (tightening torque 3 - 7 N.m).
- Fill the fuel tank with clean diesel filtered through the filler port.
- Refit the filler plug.



**REPLACE**

**Coolant**

These operations are to be carried out as necessary or every 2 years at the beginning of winter. Place the lift truck on level ground with the engine stopped and cold.

**⚠ IMPORTANT ⚠**

*The engine does not contain any anti-corrosion elements and must be filled throughout the year with a mixture containing 25% ethylene glycol-based antifreeze.*

**DRAINING THE LIQUID**

- Open the engine cover.
- Remove access panel 1.



NOTE: When removing cover plates and hatches, clean the surrounding area and remove any accumulations of flammable materials.

- Place a container under radiator drain plug 2 and unscrew the plug.
- Take drain hose 3.
- Place the end of the drain hose in the container and screw the hose fully to the drain connector 2.
- Remove filler plug 4 from the expansion tank and fully open the heating control to ensure correct drainage.
- Let the cooling circuit drain entirely while ensuring that the ports do not get clogged.
- Check the condition of the hoses as well as the fastening devices and change the hoses if necessary.
- Rinse the circuit with clean water and use a cleaning agent if necessary.



### FILLING WITH COOLANT

- Remove, clean and refit drain hose 3.
- Refit and tighten the radiator drain plug 2.
- Slowly fill the circuit with coolant (⚠ LUBRICANTS AND FUEL) up to the MAX level of the expansion tank 5 through the filler hole.
- Refit the filler plug 4.
- Run the engine at idle for a few minutes.
- Check for any possible leaks.
- Refit access panel 1.
- Check the level and refill if necessary.



### REPLACE

#### Dry air filter cartridge

In case of use in a heavily dust laden atmosphere, there are pre-filtration cartridges, (⚠ FILTER CARTRIDGES AND BELTS). Also, the checking and cleaning periodicity of the cartridge must be reduced (up to 250 hours in a very dusty atmosphere and with pre-filtration).

**⚠ IMPORTANT ⚠**

*Change the cartridge in a clean location, with the engine stopped.  
Never operate the lift truck with a cartridge removed or damaged.*

- Open the engine cover.
- Loosen the locks and remove cover 1.
- Gently remove the cartridge 2 to reduce dust falling as far as possible.
- Leave the safety cartridge in place.
- Carefully clean the following parts with a damp, clean lint-free cloth.
  - The inside of the filter and cover.
  - The inside of the filter inlet hose.
  - The gasket surfaces in the filter and in the cover.
- Check pipes and connections between the air filter and the engine and the connection and state of the clogging indicator on the filter.
- Before fitting check the condition of the new cartridge (⚠ FILTER CARTRIDGES AND BELTS).
- Insert the cartridge in the filter axis and push the cartridge pressing against the outer edge and not the centre.
- Reassemble the cover, guiding the valve downwards.

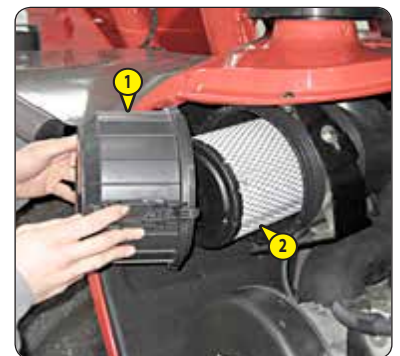

**REPLACE**

**Fuel pre-filter**

**⚠ IMPORTANT ⚠**

*Carefully clean the outside of the pre-filter and its holder, to prevent dust from getting into the system.  
Tighten the fuel filter by hand only and lock in place by a quarter turn.*

- Switch off the lift truck's ignition.
- Open the engine cover.
- Close the diesel supply with valve 1.
- Disconnect electrical wiring harness 2 from the fuel pre-filter.
- Place a hose on the drain plug 3 and the other end in a container.
- Unscrew the drain plug 3 by two turns.
- Open bleed screw 4 to ensure proper emptying.
- Retighten bleed screw 4 once the pre-filter is emptied.
- Loosen pre-filter 5 and discard it, together with its seal.
- Clean the inside of the pre-filter head using a brush immersed in clean diesel oil.
- Refit a pre-filter and a new seal lubricated with clean diesel beforehand (⚠ FILTER CARTRIDGES AND BELTS).
- Reconnect electrical wiring harness 2 on the fuel pre-filter.
- Replace the fuel filter.



**REPLACE**

**Fuel filter**

**⚠ IMPORTANT ⚠**

*Carefully clean the outside of the filter and its holder, to prevent dust from getting into the system.*

- Unscrew and discard the fuel filter 1.
- Clean the inside of the filter head using a brush immersed in clean diesel oil.
- Refit a filter and a new seal lubricated with clean diesel beforehand (⚠ FILTER CARTRIDGES AND BELTS).
- Tighten the filter, making sure that the seal is correctly positioned (tightening torque 10 - 12 N.m).
- Open the diesel supply with valve 2.
- Open the bleed screw 4 of the fuel pre-filter and the bleed screw 3 of the fuel filter.
- Switch on the lift truck's ignition, and close the bleed screw as soon as the diesel flows with no air.



**REPLACE**

**Alternator belt**

**⚠ IMPORTANT ⚠**

*Check the belt tension again after the first 20 hours of operation.*

- Open the engine cover.
- Remove the protective casing 1.
- Loosen the screws 2 and 3 by two to three thread turns.
- Loosen the screw 4 to swivel the alternator assembly so as to free the belt 5.
- Remove the belt and replace with a new one (⚠ FILTER CARTRIDGES AND BELTS).
- Adjust the belt tension between the crankshaft and alternator pulleys.
- Tighten the screw 4 to tighten the belt to the tension required.
- Under a normal pressure exerted with the thumb (45 N), the clearance should be approximately 10 mm.
- Retighten the screws 2 (tightening torque 30 N.m) and the screw 3 (tightening torque 42 N.m).
- Refit the protective casing 1.

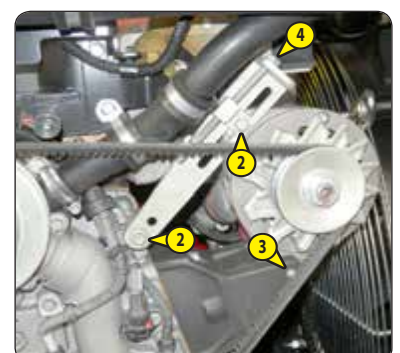

**REPLACE**

**Gearbox oil**

**CLEAN**

**Gearbox sump strainer**

Place the lift truck on level ground with the engine stopped and the gear box oil still warm.

**⚠ IMPORTANT ⚠**

*Raise the boom and place the boom safety wedge on the rod of the lifting cylinder (↖ 1 - INSTRUCTIONS AND SAFETY RECOMMENDATIONS: LIFT TRUCK MAINTENANCE INSTRUCTIONS).  
Dispose of the drain oil in an ecological manner.*

**DRAINING THE OIL**

- Place a container under drain plug 1 and under cover 2 and unscrew the drain plug.
- Remove the cover plate 3.

NOTE: When removing cover plates and hatches, clean the surrounding area and remove any accumulations of flammable materials.

- Remove dipstick 4 and unscrew filling plug 5 in order to ensure that the oil is drained properly.

**CLEANING THE STRAINER**

- Remove cover 2 and set aside the O-ring joint and sealing washer.
- Allow the rest of the oil to drain away.
- Remove and clean the strainer using a compressed air jet.
- Clean the magnetic section on the plate.
- Refit the assembly and tighten up plate 2 (tightening torque 18 - 31 N.m).

**FILLING WITH OIL**

- Refit and tighten the drain plug 1 (tightening torque 34 - 54 N.m).
- Fill up with oil (↖ LUBRICANTS AND FUEL) through the filler port 5 and refit the plug.
- Start the engine and let it run for a few minutes.
- Check any possible leaks from the drain plug or cover.
- Stop the engine, and within 5 minutes of the engine being stopped, check the correct level between the MIN and MAX marks on the dipstick 4.
- Top up the level if necessary.
- Refit cover plate 3.

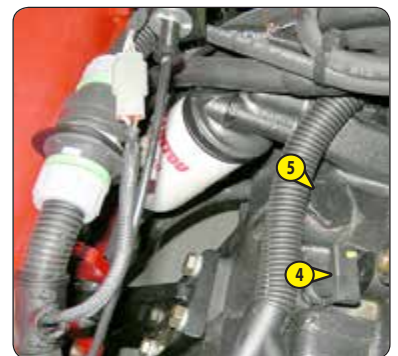

**REPLACE**

**Angle gear box oil**

Place the lift truck on level ground with the engine stopped, the angle gear box oil still warm.

**⚠ IMPORTANT ⚠**

*Raise the boom and place the boom safety wedge on the rod of the lifting cylinder (↖ 1 - INSTRUCTIONS AND SAFETY RECOMMENDATIONS: LIFT TRUCK MAINTENANCE INSTRUCTIONS).*

*Dispose of the drain oil in an ecological manner.*

- Place a container under drain plug 1 and unscrew the plug.
- Remove dipstick 2 and unscrew filling plug 3 in order to ensure that the oil is drained properly.
- Refit and tighten the drain plug 1 (tightening torque 20 - 29 N.m).
- Fill up with oil (↖ LUBRICANTS AND FUEL) through the filler port 3 and refit the plug.
- Check the correct level between the MIN and MAX marks on dipstick 2.
- Check for any possible leaks at the drain plug.

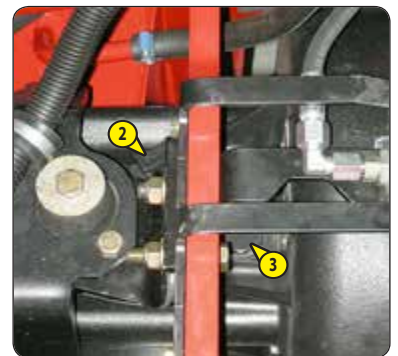

**REPLACE**

**Front wheel reducer oil**

**REPLACE**

**Rear wheel reducer oil**

Place the lift truck on level ground with the engine stopped and the reducers' oil still warm.

**⚠ IMPORTANT ⚠**

*Dispose of the drain oil in an ecological manner.*

- Drain and change the oil of each wheel reduction gear.
- Place drain plug 1 in position A.
- Place a container under the drain plug and unscrew the plug.
- Let the oil drain fully.
- Place the drain port in position B, i.e. in a level port.
- Fill up with oil (↖ LUBRICANTS AND FUEL) through level hole 1.
- The level is correct when the oil level is flush with the edge of the hole.
- Refit and tighten the drain plug (tightening torque 34 - 49 N.m).

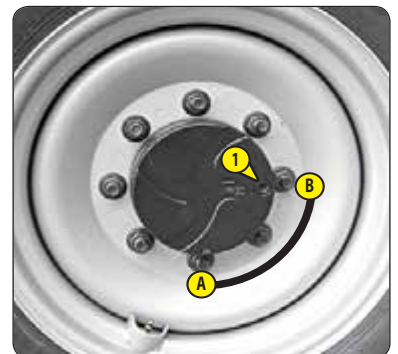



<b>CHECK</b>	<b>Engine silent blocks *</b>
<b>CHECK</b>	<b>Valve lash *</b>
<b>CHECK</b>	<b>Gearbox silent blocks *</b>
<b>CHECK</b>	<b>Gear box controls *</b>
<b>CHECK</b>	<b>Brake system pressure *</b>
<b>CHECK</b>	<b>Boom pad wear *</b>
<b>CHECK</b>	<b>Condition of wiring harnesses and cables *</b>
<b>CHECK</b>	<b>Lights and signals *</b>
<b>CHECK</b>	<b>Warning indicators *</b>
<b>CHECK</b>	<b>Condition of the rear-view mirrors *</b>
<b>CHECK</b>	<b>Cabin structure *</b>
<b>CHECK</b>	<b>Frame structure *</b>
<b>CHECK</b>	<b>Attachment carriage *</b>
<b>CHECK</b>	<b>Condition of attachments *</b>
<b>REPLACE</b>	<b>Brake fluid *</b>
<b>BLEED</b>	<b>Brake circuit *</b>
<b>ADJUST</b>	<b>Brake *</b>

*\* Consult your dealer.*

**➔ 2000H - PERIODIC SERVICE - EVERY 2,000 HOURS OF SERVICE OR 4 YEARS**

*ALSO PERFORM THE 500 HOUR AND 1,000 HOUR PERIODIC MAINTENANCE OPERATIONS.*

**CHECK**

**Wheel nut tightening torques**

- Check the condition of the tyres to detect cuts, blisters, wear, etc.
- Check the tightening torque of the wheel nuts with a torque wrench:
  - Front wheels = 630 N.m ± 94 N.m
  - Rear wheels = 630 N.m ± 94 N.m

**CLEAN**

**Air conditioning (OPTION) \***

**CLEANING CONDENSER AND EVAPORATOR COILS**

**CLEANING CONDENSATE TRAY AND RELIEF VALVE**

**COLLECTING COOLANT TO REPLACE DRIER FILTER**

**REFILLING WITH COOLANT AND CHECKING THE THERMOSTATIC CONTROL AND PRESSURE SWITCHES**

NOTE: When opening the evaporator unit, remember to replace the cover seal.

**⚠ IMPORTANT ⚠**

**NEVER TRY TO REPAIR ANY FAULTS YOURSELF.**

**WHEN REFILLING CIRCUITS, ALWAYS REFER TO A DEALER WHO HAS THE CORRECT SPARE PARTS AND THE TECHNICAL KNOWLEDGE AND TOOLS REQUIRED.**

*In any of the following circumstances, call a doctor.*

*If inhaled, take the victim to fresh air.*

*If there is contact with the skin, wash immediately with plenty of water.*

*If there is frostbite, apply a sterile dressing.*

*If there is contact with the eyes, rinse with clear water for 15 minutes.*



**IMPORTANT INFORMATION REGARDING THE COOLANT USED**

- This product contains fluorinated greenhouse gases covered by the Kyoto Protocol.
- Coolant type: R134A; it is colourless and odourless and heavier than air. Its GWP (Global Warming Potential) is 1,430.
- Do not allow the gases to escape into the atmosphere. Do not open the circuit under any circumstances, as this could cause refrigerant to escape.
- The compressor has a fluid level gauge; never unscrew this gauge because it would depressurise the system. The fluid level should only be checked when draining the system.

*\* Consult your dealer.*

**REPLACE**

**Dry air filter safety cartridge**

**⚠ IMPORTANT ⚠**

**The safety cartridge replacement frequency is given for information only. It must be changed every second time the dry air filter cartridge is changed.**

- For the dismantling and refitting of the cartridge (↩ 1000H: REPLACE Air filter cartridge).
- Remove the dry air filter safety cartridge 1 carefully, to minimise dust fall.
- Clean the gasket surface on the filter with a damp, clean lint-free cloth.
- Check the condition of the new safety cartridge before fitting (↩ FILTER CARTRIDGES AND BELTS).
- Insert the cartridge in the filter axis and push the cartridge pressing against the outer edge and not the centre.



**REPLACE**

**Hydraulic oil**

**CLEAN**

**Hydraulic oil tank suction strainer**

**REPLACE**

**Hydraulic oil tank filter cap**

**REPLACE**

**Distributor control head filter**

Place the lift truck on level ground with the engine shut down, and the boom retracted and lowered as far as possible.

**⚠ IMPORTANT ⚠**

*Before any intervention, thoroughly clean the area surrounding the filter, the drain plugs and the suction cover on the hydraulic tank.*

*Dispose of the drain oil in an ecological manner.*

*Use a very clean container and funnel and clean the underside of the oil drum before filling.*

**DRAINING THE OIL**

- Place a container under drain plugs 1 and unscrew them.
- Remove level and filling plug 2 to ensure that the oil is drained properly and discard.

**CLEANING THE STRAINER**

- Remove the inlet cover 3.
- Remove and clean the suction strainer using a compressed air jet, check its condition and replace if necessary (↩ FILTER CARTRIDGES AND BELTS).
- Refit the strainer and tighten the inlet cover 3 (tightening torque 81 N.m) making sure the seal is in the correct position.

**REPLACING THE DISTRIBUTOR CONTROL HEAD FILTER**

**⚠ IMPORTANT ⚠**

*Be careful to mount the filter 6 in the same direction as the arrow.*

- Remove the half clamp 4.
- Undo the two couplings 5 and replace the filter 6.
- Refit half clamp 4.

**FILLING WITH OIL**

- Clean and refit the drain plugs 1 (tightening torque 29 - 39 N.m).
- Fill up with oil (↩ LUBRICANTS AND FUEL) through filler hole 7.
- Observe the oil level on dipstick 8, the oil level should be at the level of the red dot.
- Check for any possible leaks at the drain plugs.
- Replace filler plug with a new filler plug 2 (↩ FILTER CARTRIDGES AND BELTS).

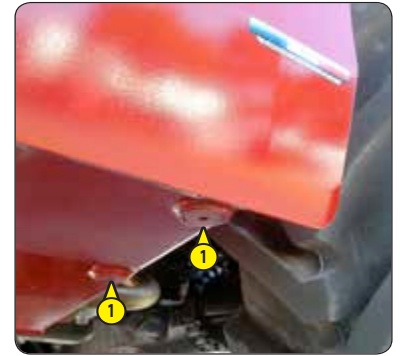



<b>CHECK</b>	<b>Radiator *</b>
<b>CHECK</b>	<b>Water pump and thermostat *</b>
<b>CHECK</b>	<b>Alternator and starter *</b>
<b>CHECK</b>	<b>Turbocharger *</b>
<b>CHECK</b>	<b>Transmission pressures *</b>
<b>CHECK</b>	<b>Steering *</b>
<b>CHECK</b>	<b>Steering swivel joints *</b>
<b>CHECK</b>	<b>Brake pad and brake disk wear *</b>
<b>CHECK</b>	<b>Condition of boom assembly *</b>
<b>CHECK</b>	<b>Bearings and bushings of the boom *</b>
<b>CHECK</b>	<b>Condition of hoses and flexible pipes *</b>
<b>CHECK</b>	<b>Condition of cylinders (leakage, rods) *</b>
<b>CHECK</b>	<b>Hydraulic circuit pressures *</b>
<b>CHECK</b>	<b>Bearings and bushings of the frame *</b>
<b>REPLACE</b>	<b>Compressor belt (Air Conditioning OPTION) *</b>

*\* Consult your dealer.*



## ➔ OCCASIONAL MAINTENANCE

### CLEAN

### "Stationary lift truck" exhaust regeneration

**⚠ IMPORTANT ⚠**

*If you are performing regeneration during the periodic 500-hour service, do the regeneration before replacing the engine oil.*

- Park the lift truck in a safe and adequately ventilated place.
- Check the following points:
  - forward/reverse selector in neutral,
  - parking brake applied,
  - no action on the hydraulic control joystick,
  - boom in transport position,
  - idling speed,
- Check that the fuel level is sufficient.
- Start the lift truck and run the engine for a few minutes to bring it up to its normal operating temperature.
- Press the top of switch 1 and hold for at least two seconds to launch exhaust regeneration. Indicator lamp  coming on fixed and the engine speed increasing confirm the start of regeneration.
- The length of the exhaust regeneration procedure varies (between 40 and 50 minutes).

**⚠ IMPORTANT ⚠**

*Exhaust regeneration must only be stopped if absolutely necessary.*

*Regeneration stops automatically if the operator:*

- activates the hydraulic control joystick,
- engages forward or reverse gear,
- switches off the engine,
- presses switch 1.

- When regeneration is complete, the indicator lamp  goes out and the countdown to next regeneration screen reverts to 700 hours (700h => 0h).



### REPLACE

### Wheels

For this operation, we advise you to use the hydraulic jack (MANITOU part no.: 505507) and the safety support prop (MANITOU part no.: 554772).

**⚠ IMPORTANT ⚠**

*In the event of a wheel being changed on the public highway, secure the lift truck vicinity:*

- Stop the lift truck, if possible on firm, level ground.
- Stop the lift truck (⚠ 1 - OPERATING AND SAFETY INSTRUCTIONS: DRIVING INSTRUCTIONS UNLADEN AND LADEN).
- Switch on the hazard warning lights.
- Immobilise the lift truck in both directions on the axle opposite to the wheel to be changed.
- Unlock the nuts of the wheel to be changed.
- Place the jack under the flared axle tube, as near as possible to the wheel and adjust the jack.
- Raise the wheel until it is clear of the ground and place the safety support under the axle.
- Completely unscrew the wheel nuts and remove them.
- Free the wheel by reciprocating movements and roll it to the side.
- Slip the new wheel on the wheel hub.
- Hand-tighten the nuts, grease them if necessary.
- Remove the safety support and lower the lift truck with the jack.
- Tighten the wheel nuts with a torque wrench (⚠ 2000H - PERIODIC SERVICE - EVERY 2,000 HOURS OF SERVICE OR EVERY 4 YEARS) for the tightening torque.



**REPLACE**

**Battery**

**⚠ IMPORTANT ⚠**

Operate the battery cut-off for a minimum of 30 seconds after having switched off the ignition with the ignition key.  
Handling and servicing a battery can be dangerous, take the following precautions:

- Wear protective goggles.
  - Keep the battery horizontal.
  - Never smoke or work near a naked flame.
  - Work in a well-ventilated area.
- In the event of electrolyte being spilled onto the skin or splashed in the eyes, rinse thoroughly with cold water for 15 minutes and call a doctor.

- Remove the protective casing 1.
- Bring a backup battery of the same type as that of the lift truck, together with battery cables.
- Connect the back-up battery, respecting the polarity (-) (+).
- Start the lift truck and remove the cables as soon as the engine is running.

**⚠ IMPORTANT ⚠**

Raise the boom and place the boom safety wedge on the rod of the lifting cylinder (↖ 1 - INSTRUCTIONS AND SAFETY RECOMMENDATIONS: LIFT TRUCK MAINTENANCE INSTRUCTIONS).

- Change the battery 2.

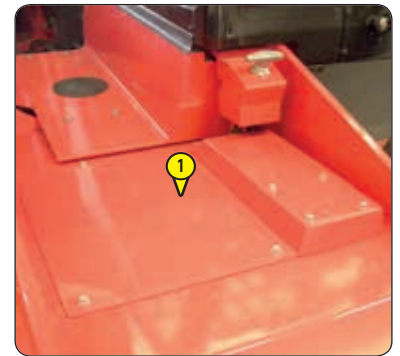

**ADJUST**

**Front headlights**

**RECOMMENDED SETTING**

(according to standard ECE-76/756 76/761 ECE20)

Adjustment of -2 % of the dipped beam harness relative to the horizontal axis of the headlight.

**ADJUSTMENT PROCEDURE**

- Place the unladen lift truck in the transport position and perpendicular to a white wall on flat, level ground.
- Check the tyre pressures (↖ 2 - DESCRIPTION: TYRES).
- Place the forward/reverse selector in neutral.

**CALCULATING THE HEIGHT OF THE DIPPED BEAM (H2)**

- h1 = Height of the dipped beam in relation to the ground.
- h2 = Height of the adjusted beam.
- l = Distance between the dipped beam and the white wall.

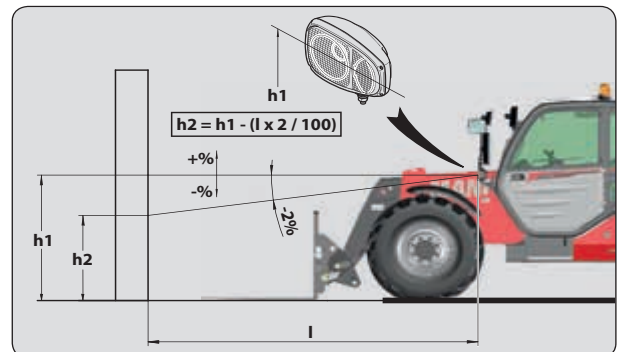

**RESET**

**Longitudinal stability limiter and warning device**

According to the use of the lift truck, the device may require to be periodically reset.

This operation can be easily performed by means of the following procedure.

- Provide a fork carrier or a bucket and a load corresponding to at least half the lift truck's rated capacity.
- Preferably perform the reset when the lift truck is still cold (before it is used) or ensure that the temperature of the rear axle is not more than 50 °C.

**⚠ IMPORTANT ⚠**

*Carefully follow the boom positioning instructions.*

*Should you fail to follow these instructions, two audible signals will be sounded and the fault indicator lamp will come on. If in doubt, consult your dealer. When the reset is completed, check the operation of the longitudinal stability limiter and warning device (⏰ 10H - DAILY SERVICE OR EVERY 10 HOURS OF SERVICE). If in doubt, contact your dealer.*

- Place the lift truck on flat, level ground with the wheels straight.

<p><b>STEP 1 ENTRY</b> ↓</p>		<p>→ <b>Simultaneously press and hold down the "BUCKET" MODE  and TEST  buttons.</b></p> <ul style="list-style-type: none"> <li>- Two audible signals will sound and all the LEDs will flash twice to confirm the start of the procedure.</li> </ul>	
<p><b>STEP 2</b> ↓</p>		<p>→ Without attachments. → Carriage tilted fully backwards. → Boom fully retracted and in the down position a few centimetres off the ground.</p>	<p>→ <b>Short press the test button.</b></p>
<p><b>STEP 3</b> ↓</p>		<p>→ With the fork carrier or the bucket and a load (keep boom retracted to allow all other hydraulic movements). → Boom fully retracted and in the down position a few centimetres off the ground.</p> <p><b>⚠ IMPORTANT ⚠</b> <i>Always keep the load as close to the ground as possible during this operation.</i></p> <ul style="list-style-type: none"> <li>- Hold down the disable the "aggravating" hydraulic movement cut-off button  (indicator lamp lit), and telescope the boom until the rear wheels leave the ground.</li> </ul> <p>NOTE: This stage consists in unloading the rear axle. It can be done using a jack but without bearing on the rear axle.</p>	<p>→ <b>Short press the test button.</b></p> <p>→ <b>Two audible signals will sound and all the LEDs will flash twice to confirm the end of the procedure.</b></p>
<p><b>STEP 4 EXIT</b></p>		<p>→ After completing the resetting procedure, the lift truck is in an overloaded condition. Retract the telescope to restore the situation.</p>	



## ↻ OCCASIONAL OPERATION

### TOW OR WINCH

### Lift truck

#### ⚠ IMPORTANT ⚠

*Do not tow the lift truck at more than 15 km/h, and abide by local traffic regulations.*

- Place the forward/reverse selector and the gear lever in neutral.
- Release the hand brake.
- Switch on the hazard warning lights.

Since there will be no steering or braking hydraulic assistance, operate the steering and pedal slowly, avoiding sudden or jerky movements.

### SLING

### Lift truck

- Take into account the position of the lift truck centre of gravity for lifting.
 

A = 1430 mm	B = 1380 mm	MT 733...
A = 1450 mm	B = 1360 mm	MT 933...
A = 1250 mm	B = 1440 mm	MT 1033...
- Place the hooks in the fastening points 1 provided.

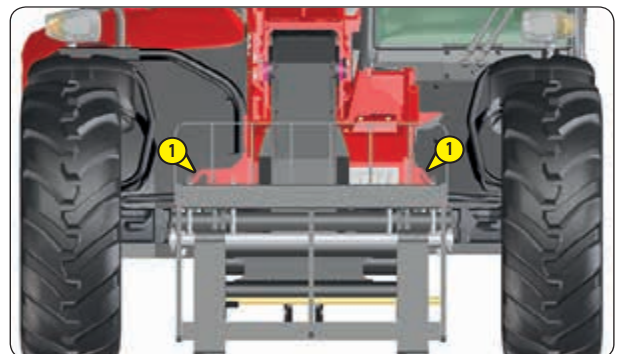
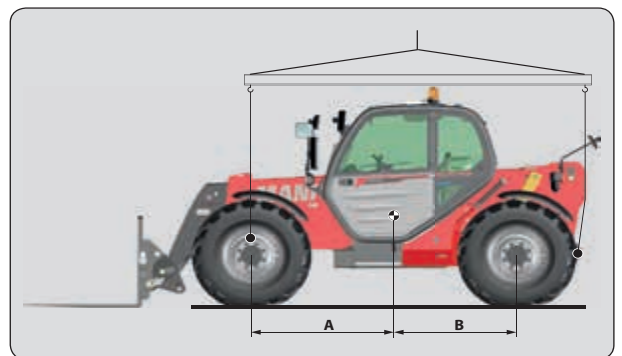

**TRANSPORT**

**Lift truck**

**⚠ IMPORTANT ⚠**

Ensure that the safety instructions associated with the flatbed are complied with before loading the lift truck and that the driver of the carrier vehicle is informed of the dimensions and the weight of the lift truck (↩ 2 - DESCRIPTION: CHARACTERISTICS).

Ensure that the platform is of sufficient size and load capacity for transporting the lift truck. Check also the allowable ground contact pressure of the platform relative to the lift truck.

**⚠ IMPORTANT ⚠**

For lift trucks equipped with a turbo-charged engine, block off the exhaust outlet to avoid rotation of the turbo shaft without lubrication when transporting the vehicle.

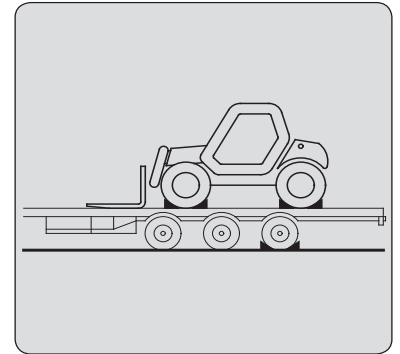

**LOADING THE LIFT TRUCK**

- Block the wheels of the platform.
- Attach the loading ramps to the platform in such a way as to give the shallowest possible ramp angle for the lift truck.
- Load the lift truck parallel to the platform.
- Stop the lift truck (↩ 1 - OPERATING AND SAFETY INSTRUCTIONS: DRIVING INSTRUCTIONS UNLADEN AND LADEN).

**STOWING THE LIFT TRUCK**

- Fix the chocks to the flatbed at the front and at the back of each tyre.
- Also fix the chocks to the flatbed on the inside of each tyre.
- Secure the lift truck to the flatbed with straps, in the anchoring points 1 provided.
- In order to ensure the lift truck is securely lashed to the flatbed, observe the lashing angles ( $\alpha$ ) and ( $\beta$ ) and the resistance (LC) of the straps.
- Tighten the straps.

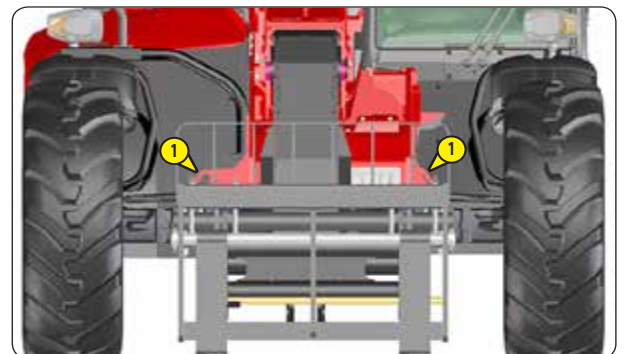
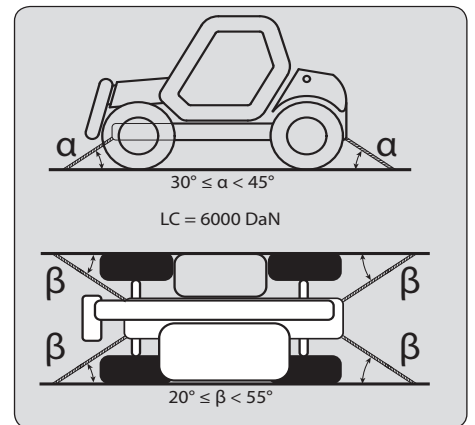





# ***4 - OPTIONAL ADAPTABLE ATTACHMENTS FOR THE RANGE***



## 4 - OPTIONAL ADAPTABLE ATTACHMENTS FOR THE RANGE

<i>INTRODUCTION</i>	<i>4-3</i>
<i>PICKING UP THE ATTACHMENTS</i>	<i>4-4</i>
<i>TECHNICAL SPECIFICATIONS OF ATTACHMENTS</i>	<i>4-6</i>
<i>ATTACHMENT GUARDS</i>	<i>4-12</i>



## INTRODUCTION

- Your lift truck must be used with interchangeable equipment. These items are called: ATTACHMENTS.
- A wide range of attachments is available, guaranteed by MANITOU and designed to fit your lift truck perfectly.

**⚠ IMPORTANT ⚠**

*Only attachments approved by MANITOU can be used on its lift trucks (← TECHNICAL CHARACTERISTICS OF ATTACHMENTS).  
The manufacturer cannot be held responsible for any modifications or adaptations to attachments without its knowledge.*

- The attachments are delivered with a load chart concerning your lift truck. The operator's manual and the load chart should be kept in the places provided in the lift truck. For standard attachments, their use is governed by the instructions contained on this notice.

**⚠ IMPORTANT ⚠**

*Maximum loads are defined by the capacity of a lift truck taking account of the attachment's mass and centre of gravity.  
Should the attachment have a lower capacity than the lift truck, never exceed this limit.*

- Some particular uses require the adaptation of the attachment which is not provided in the price-listed options. Optional solutions exist, consult your dealer.

**⚠ IMPORTANT ⚠**

*Depending on their size, certain attachments may, when the boom is lowered and retracted, come into contact with the front tyres and cause damage to them if excavation is activated in the direction of the discharge.*

**TO PREVENT THIS RISK, EXTEND THE TELESCOPE TO A SUFFICIENT EXTENT FOR THE PARTICULAR LIFT TRUCK AND ATTACHMENT SO THAT THIS CONTACT IS NOT POSSIBLE.**

### SUSPENDED LOAD

**⚠ IMPORTANT ⚠**

*Suspended loads MUST be handled with a lift truck designed for that purpose (← 1 - OPERATING AND SAFETY INSTRUCTIONS: LOAD HANDLING INSTRUCTIONS: H - PICKING UP AND PUTTING DOWN A SUSPENDED LOAD).*

### USE OF BUCKETS

**⚠ IMPORTANT ⚠**

*MT 733/933/1033 lift trucks are essentially intended for handling, for which occasional use with the buckets CBC/CBR/CB4x1 is authorised (only with the boom fully retracted, in order to reduce stresses on the boom head), but under no circumstances for difficult applications (quarry, waste, cereals, agriculture, etc).*

## PICKING UP THE ATTACHMENTS

### 1 - ATTACHMENT WITHOUT HYDRAULICS AND HAND LOCKING DEVICE

#### FITTING AN ATTACHMENT

- Ensure that the attachment is in a position facilitating the locking to the carriage. If it is not correctly oriented, take the necessary precautions in order to move it safely.
- Check that the locking pin is in position in the bracket (Fig. A).
- Place the lift truck with the boom lowered in front of and parallel to the attachment, and tilt the carriage forwards (Fig. B).
- Bring the carriage under the locking tube of the attachment, slightly raise the boom, tilt the carriage backwards in order to position the attachment (Fig. C).
- Lift the attachment off the ground to facilitate locking.

#### MANUAL LOCKING

- Take the locking pin on the bracket (Fig. A) and lock the attachment (Fig. D). Do not forget to fit the cotter pin.

#### MANUAL UNLOCKING

- Proceed in the reverse order to MANUAL LOCKING, taking care to refit the locking pin in the bracket (Fig. A).

#### REMOVING THE ATTACHMENT

- Proceed in the reverse order to FITTING AN ATTACHMENT, taking care to store the attachment flat on the ground and in the closed position.

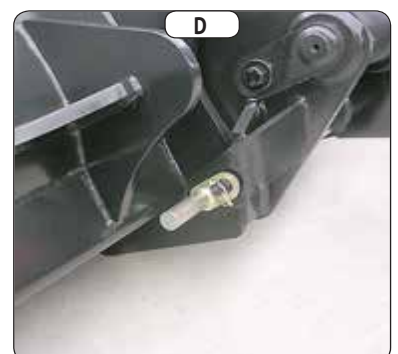
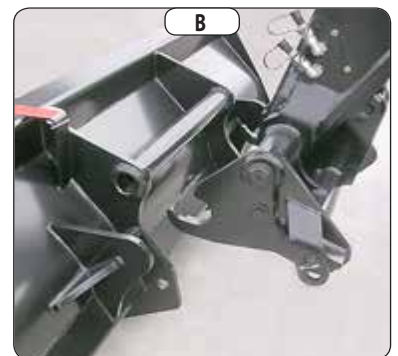
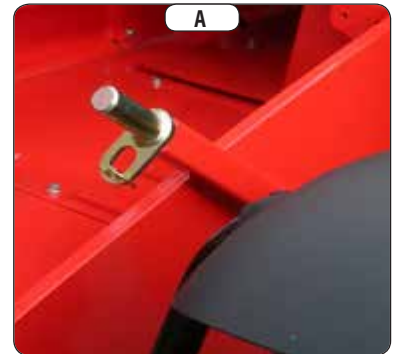

## 2 - HYDRAULIC ATTACHMENT AND MANUAL LOCKING DEVICE

### FITTING AN ATTACHMENT

- Ensure that the attachment is in a position facilitating the locking to the carriage. If it is not correctly oriented, take the necessary precautions in order to move it safely.
- Check that the locking pin is in position in the bracket (Fig. A).
- Place the lift truck with the boom lowered in front of and parallel to the attachment, and tilt the carriage forwards (Fig. B).
- Bring the carriage under the locking tube of the attachment, slightly raise the boom, tilt the carriage backwards in order to position the attachment (Fig. C).
- Lift the attachment off the ground to facilitate locking.

### MANUAL LOCKING AND CONNECTION OF THE ATTACHMENT

#### ⚠ IMPORTANT ⚠

*Make sure that the rapid connectors are clean and protect the holes which are not used, with the caps provided.*

- Take the locking pin on the bracket and lock the attachment (fig. D). Do not forget to fit the cotter pin.
- Stop the engine and keep the ignition on the lift truck.
- Release the pressure in the attachment hydraulic circuit by moving switch 1 on the hydraulic controls lever backwards and forwards 4 or 5 times.
- Connect the quick-release couplers according to the logic of the attachment's hydraulic movements.

### MANUAL RELEASE AND DISCONNECTION OF THE ATTACHMENT

- Proceed in the reverse order of paragraph MANUAL LOCKING AND CONNECTION OF THE ATTACHMENT, taking care to refit the locking pin in the bracket.

### REMOVING THE ATTACHMENT

- Proceed in the reverse order to FITTING AN ATTACHMENT, taking care to store the attachment flat on the ground and in the closed position.

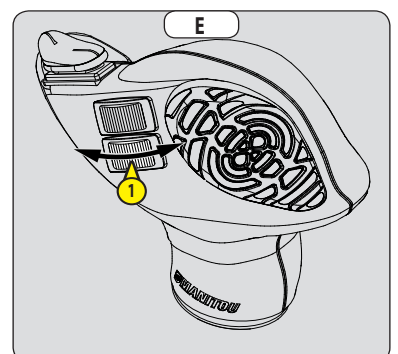
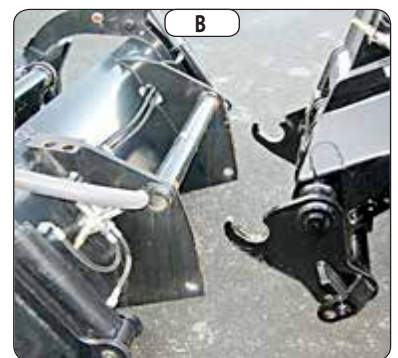
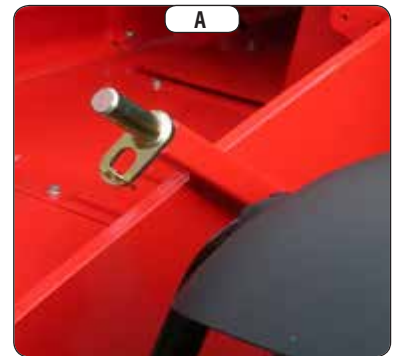



## TECHNICAL SPECIFICATIONS OF ATTACHMENTS

### FLOATING FORK CARRIAGE

	TFF 35 MT-1040	TFF 35 MT-1300
<b>PART No.</b>	<b>654093</b>	<b>654094</b>
Rated capacity	3500 kg	3500 kg
Width	1040 mm	1300 mm
Weight	300 kg	340 kg

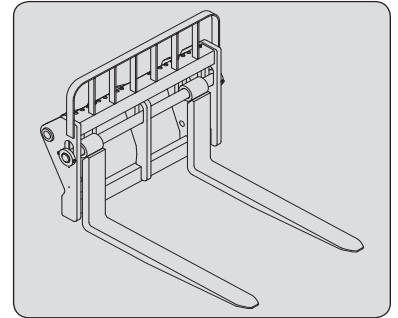

### FLOATING FORK SIDE-SHIFT CARRIAGE

	TFF 35 MT-1040 DL	TFF 35 MT-1300 DL
<b>PART No.</b>	<b>751543</b>	<b>751544</b>
Rated capacity	3500 kg	3500 kg
Side-shift	2x100 mm	2x100 mm
Width	1040 mm	1300 mm
Weight	345 kg	375 kg

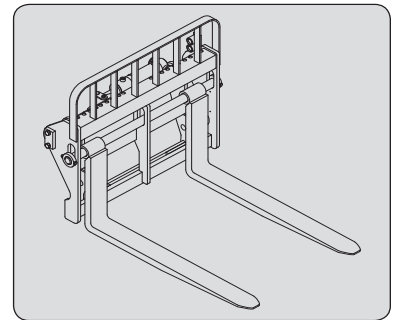

### FLOATING FORK

	<b>PART No.</b>	<b>415801</b>
Section		125x45x1200 mm
Weight		68 kg

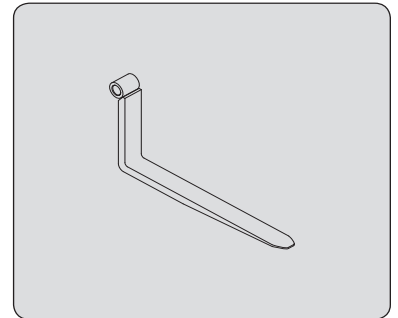

### FORK POSITIONER

	<b>CAF 1260/4500 P</b>
<b>PART No.</b>	<b>52000273</b>
Rated capacity	4500 kg
Spacing	275/1010 mm
Width	1260 mm
Weight	350 kg

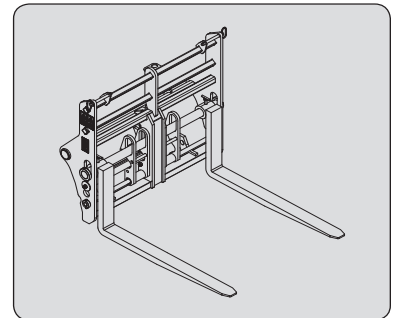

### FLOATING FORK

	<b>PART No.</b>	<b>719611</b>
Section		100x50x1200 mm
Weight		62 kg

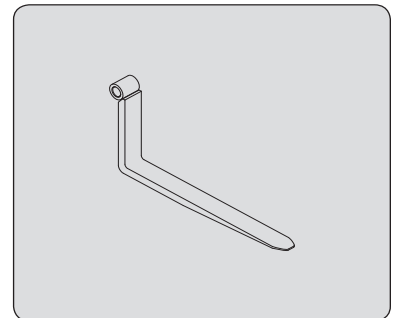



**STANDARDISED TILTING FORK CARRIAGE**

	<b>PFB 35 N MT-1260 S2</b>	<b>PFB 35 N MT-1470 S2</b>	<b>PFB 35 N MT-1580 S2</b>
<b>PART No.</b>	<b>653744</b>	<b>653745</b>	<b>653746</b>
Rated capacity	3500 kg	3500 kg	3500 kg
Width	1260 mm	1470 mm	1580 mm
Weight	95 kg	120 kg	125 kg

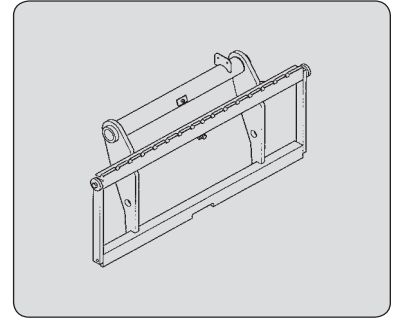

**STANDARDISED FORK**

<b>PART No.</b>	<b>415618</b>
Section	125x45x1200 mm
Weight	72 kg

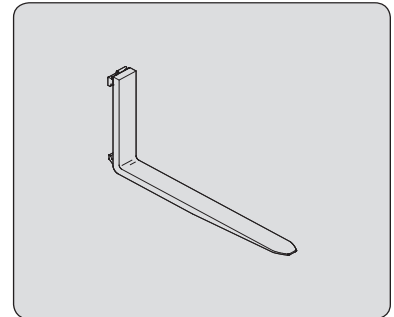

**STANDARDISED TILTING FORK CARRIAGE + STANDARDISED SIDE-SHIFT CARRIAGE**

	<b>PFB 35 N 1260 DL</b>	<b>PFB 35 N 1580 DL</b>
<b>PART No.</b>	<b>52000101</b>	<b>52000102</b>
Rated capacity	3150 kg	3150 kg
Side-shift	2x100 mm	2x100 mm
Width	1260 mm	1580 mm
Weight	175 kg	300 kg

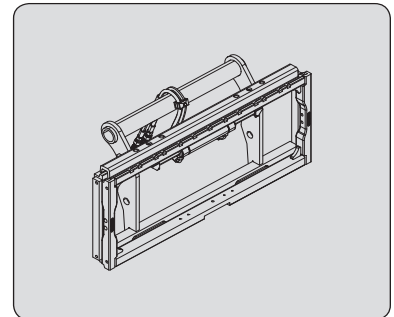

**STANDARDISED TILTING FORK CARRIAGE + LOAD BACK REST**

	<b>PFB 35N 1260 LB</b>	<b>PFB 35N 1470 LB</b>
<b>PART No.</b>	<b>52000200</b>	<b>52000201</b>
Rated capacity	3500 kg	3500 kg
Width	1260 mm	1470 mm
Weight	130 kg	158 kg

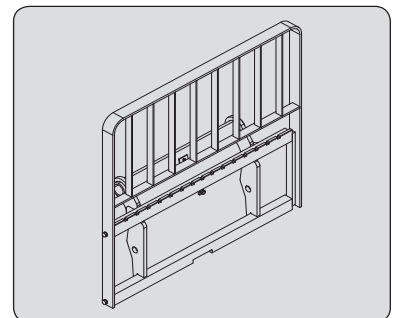

**STANDARDISED TILTING FORK CARRIAGE + STANDARDISED SIDE-SHIFT CARRIAGE + LOAD BACK REST**

<b>PART No.</b>	<b>52000205</b>
Rated capacity	3150 kg
Side-shift	2x100 mm
Width	1260 mm
Weight	210 kg

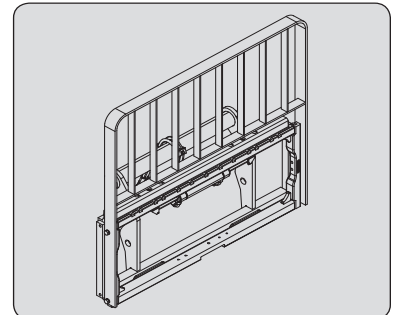



**BUILDING BUCKET**

	<b>CBC 800 L2250</b>	<b>CBC 900 L2450</b>
<b>PART No.</b>	<b>654471</b>	<b>654470</b>
Rated capacity	814 ℓ	893 ℓ
Width	2250 mm	2450 mm
Weight	366 kg	391 kg

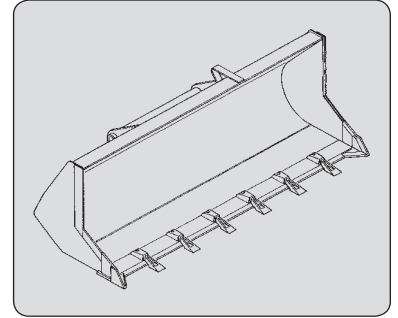

**LOADING BUCKET**

	<b>CBR 900 L2250</b>	<b>CBR 1000 L2450</b>
<b>PART No.</b>	<b>653749</b>	<b>654716</b>
Rated capacity	904 ℓ	990 ℓ
Width	2250 mm	2450 mm
Weight	390 kg	410 kg

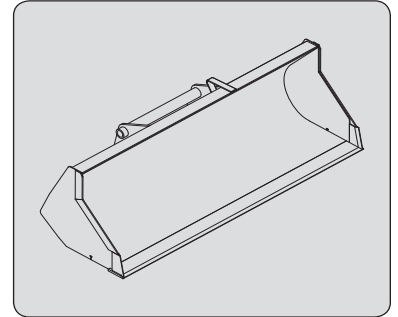

**CLAMSHELL BUCKET (REMOVABLE AND REVERSIBLE BLADE)**

	<b>CBR 1000 L2450 LDR</b>
<b>PART No.</b>	<b>52000370</b>
Rated capacity	990 ℓ
Width	2450 mm
Weight	441 kg

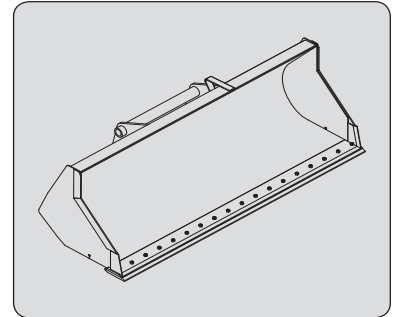

**MULTIPURPOSE BUCKET DISPLAY**

	<b>CB4X1-700 L1950</b>	<b>CB4X1-850 L2300</b>	<b>CB4X1-900 L2450</b>
<b>PART No.</b>	<b>751402</b>	<b>751401</b>	<b>751465</b>
Rated capacity	700 ℓ	850 ℓ	900 ℓ
Width	1950 mm	2300 mm	2450 mm
Weight	640 kg	735 kg	765 kg

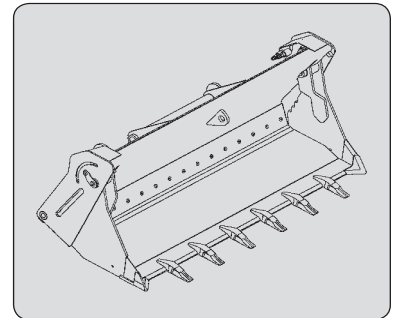



**CONCRETE BUCKET (ADAPTABLE ON FORKS)**

PART No.	BB 500 S4 654409	BBH 500 S4 751462
Rated capacity	500 ℓ/1300 kg	500 ℓ/1300 kg
Width	1100 mm	1100 mm
Weight	205 kg	220 kg

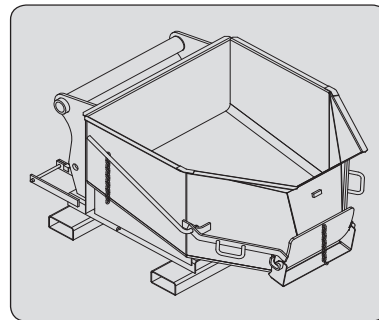

**CONCRETE BUCKET WITH SPOUT (ADAPTABLE ON FORKS)**

PART No.	BBG 500 S4 654411	BBHG 500 S4 751464
Rated capacity	500 ℓ/1300 kg	500 ℓ/1300 kg
Width	1100 mm	1100 mm
Weight	220 kg	235 kg

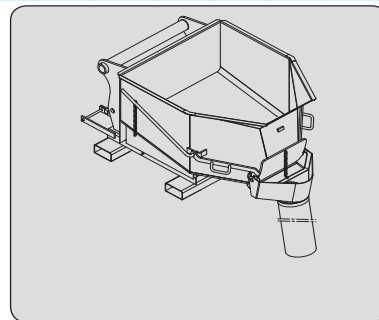

**SPOUT BUCKET (ADAPTABLE ON FORKS)**

PART No.	GL 600 S2 174373	GL 600 H S2 784630
Rated capacity	600 ℓ/1440 kg	600 ℓ/1440 kg
Weight	290 kg	290 kg

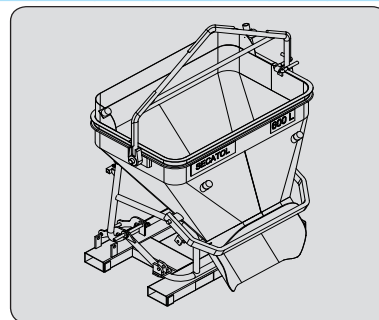



**JIB**

	<b>PART No.</b>	<b>P 600 MT S3</b>
Rated capacity		600 kg
Weight		170 kg

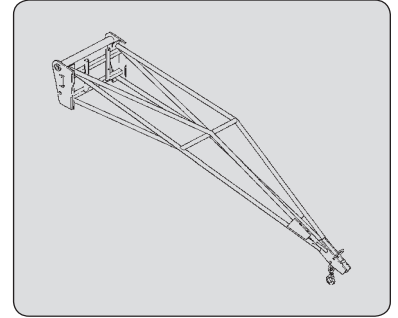

**JIB**

	<b>PART No.</b>	<b>P 4000 MT S2</b>
Rated capacity		4000 kg/1200 kg
Weight		210 kg

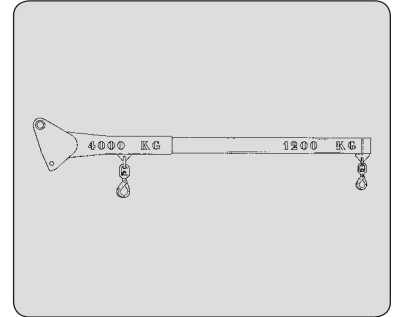

**CRANE JIB WITH WINCH**

	<b>PART No.</b>	<b>PT 600 MT S6</b>
Rated capacity		600 kg
Weight		288 kg

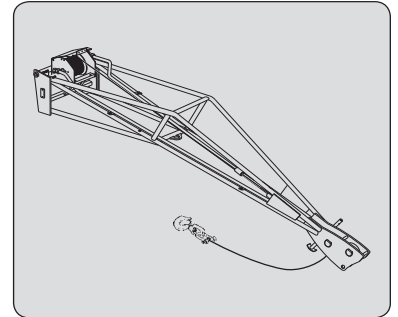

**15°/15° MULTI-DIRECTIONAL CRANE JIB**

	<b>PART No.</b>	<b>PO 600 L2500</b>	<b>PO 1000 L1500</b>	<b>PO 2000 L1000</b>
Rated capacity		600 kg	1000 kg	2000 kg
Weight		320 kg	275 kg	255 kg

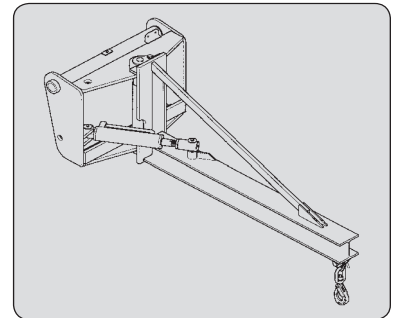

**JIB**

	<b>PART No.</b>	<b>PC 50</b>
Rated capacity		5000 kg
Weight		120 kg

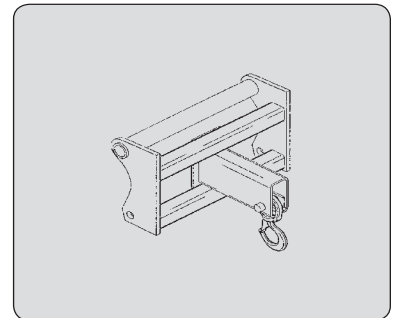



**JIB**

<b>PART No.</b>	<b>JE 6000/600</b>
Rated capacity	600 kg
Weight	182 kg

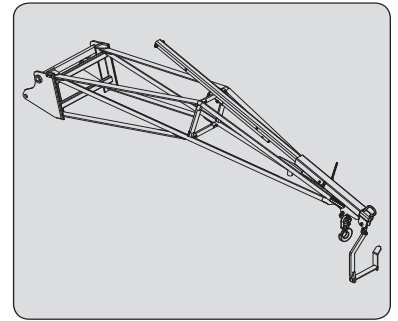

**BOOM CRANE WITH BIG BAG**

<b>PART No.</b>	<b>HBB 1500/2400</b>
Rated capacity	2400 kg
Weight	186 kg

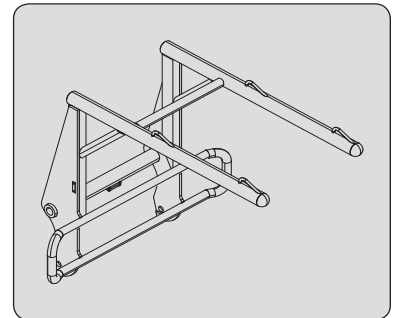



## ATTACHMENT GUARDS

### FORK GUARD

PART No. 227801

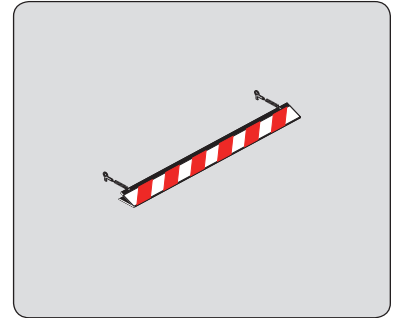

### FORK BLOCK FOR FLOATING FORK CARRIAGE

PART No. 261210

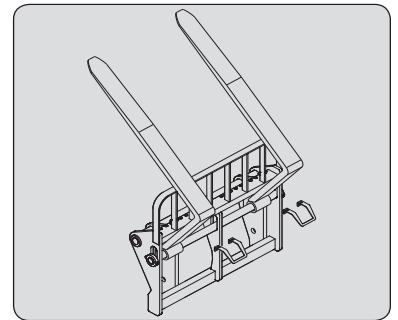

### BUCKET PROTECTOR

*Always ensure that the width of the protector you choose is less than or equal to the width of the bucket.*

Width	PART No. 206734	206732	206730
	1375 mm	1500 mm	1650 mm
Width	PART No. 235854	206728	206726
	1850 mm	1950 mm	2000 mm
Width	PART No. 223771	223773	206724
	2050 mm	2100 mm	2150 mm
Width	PART No. 206099	206722	223775
	2250 mm	2450 mm	2500 mm

