

Submersible Drainage Pump J 12-J 84
Submersible Drainage Center-line Pump JC 24-JC 84
Submersible Sludge Pump JS 12- JS 84

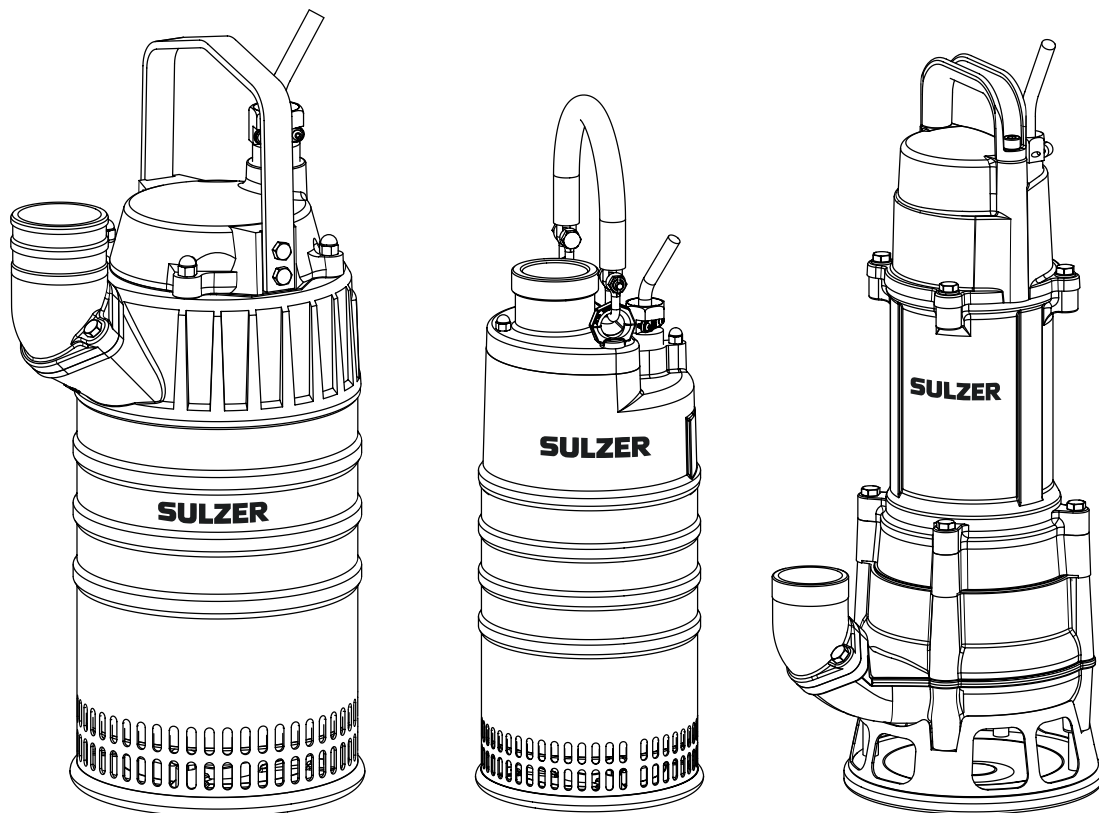

Submersible drainage pump J

J 12 (50/60 Hz)	J 15 (50/60 Hz)
J 24 (50/60 Hz)	J 44 (50/60 Hz)
J 54 (50/60 Hz)	J 84 (50/60 Hz)

Submersible drainage center-line pump JC

JC 24 (50/60 Hz)	JC 44 (50/60 Hz)
JC 54 (50/60 Hz)	JC 84 (50/60 Hz)

Submersible sludge pump JS

JS 12 (50/60 Hz)	JS 15 (50/60 Hz)
JS 24 (50/60 Hz)	JS 44 (50/60 Hz)
JS 54 (50/60 Hz)	JS 84 (50/60 Hz)

Contents

1	General.....	5
1.1	Service intervals.....	5
1.2	Repair kits.....	5
1.3	Special tools.....	5
1.4	Complete pump overhaul.....	5
1.5	Cleaning of pump before service.....	5
1.6	Recycling in case of scrapping the pumps.....	5
2	Electrical check.....	6
2.1	Pump start and cable check.....	6
2.2	Dismantling cover.....	6
2.3	Insulation test.....	6
2.4	Thermal contacts.....	6
3	J, JC Diffuser check / JS Volute removal.....	7
3.1	Dismantling handle and discharge connection.....	7
3.2	Dismantling base plate, diffuser and cooling jacket.....	7
3.3	Dismantling base plate, strainer and lower diffuser.....	7
3.4	Dismantling JS base plate, strainer and volute.....	7
4	Oil / Motor check.....	8
4.1	Oil check.....	8
4.2	Motor check.....	8
5	Change of impellers.....	8
5.1	Change of impeller.....	8
5.2	Change of lower impeller, guide vane plate, upper diffuser and upper impeller.....	9
6	Change of primary seal and wear plate.....	10
7	Complete pump overhaul / dismantling.....	11
7.1	Secondary seal.....	11
7.2	Rotor unit with oil casing.....	11
7.3	Ball bearings.....	11
7.4	Stator unit with contactor.....	11
8	Exchange of the stator.....	12
8.1	Removal of stator.....	12
8.2	Mounting of stator.....	12
8.3	Thermal contacts.....	12
9	Complete pump overhaul assembly.....	13
9.1	General.....	13
9.2	Stator unit, contactor, main cover.....	13
9.3	Ball bearings and rotor unit.....	13
9.4	Secondary seal.....	13
9.5	Primary seal and wear plate.....	14
9.6	Impeller.....	14
9.7	Refilling of oil.....	14
9.8	Diffuser and cooling jacket.....	15
9.9	Base plate.....	15
9.10	Handle, cable gland, cover and discharge connection.....	15
9.11	J 84 HD - 50 Hz.....	16
9.12	Testing.....	16

10	Electrical information and wiring diagrams	17
10.1	Three phase Direct Start D.O.L. (6-leads stator) with contactor	17
10.2	Three phase Direct Start D.O.L. 230/460V 60Hz (9-leads stator).....	18
10.3	Three phase Direkt Start D.O.L. 1000V 50Hz with terminal block	19
10.4	Three phase Star Delta starting with terminal block.....	20
10.5	Single phase	21
10.6	Fuses	22
11	Sectional drawing / Tools	23

1 General

1.1 Service intervals

This workshop manual can be used for both regular inspection and complete overhaul on the pump. For assistance contact Sulzer workshop or by Sulzer authorized workshop.

- For regular inspection on the pump such as electrical check, oil/motor check and check of hydraulic parts, proceed and follow section 1 to 6 in this manual.
- For complete overhaul on the pump proceed and follow section 1 to 9 in this manual.
- For electrical information and wiring diagrams see section 10.

Submersible drainage pumps J 12-84, JC 24-84 and Submersible sludge pumps JS 12-84 are built for long periods of trouble free operation. The pumps can “run on snore” without any risk for the mechanical seals. They get sufficient cooling from the pumped media and sufficient lubrication and cooling from the oil in the housing between the seals. All the ball bearings are sealed and prefilled with high performance bearing grease for life time duty.

Regular inspection and preventive maintenance will ensure more reliable operation. The pump should be inspected every six months and should have a complete overhaul once a year. If the operating condition of the pump is severe it may be required more frequently. A reason for inspection could be if a drop in capacity is being noticed.

1.2 Repair kits

The repair kits include preselected spare parts which secure a fast and efficient maintenance and avoids unnecessary downtime for the pump. For contents of repair kits see spare part lists.

J 12-15, JS 12-15: 00830940

J 24-44, JC 24-44, JS 24-44: 00830941

J 54-84, JC 54-84, JS 54-84: 00830942

1.3 Special tools

Sulzer submersible drainage pumps can be maintained with standard tools. Sulzer does not recommend the use of impact tools for removal and installation of screws and nuts. Some special tools are available for mechanical seal assembly. See attached drawings in section 11.

Tool for secondary seal 96990370, 00831803, 00830342

Torque rating

Size	M6	M8	M10
Nm	7	17	33
lb-ft	5.2	12.5	24.3

Cable gland: A specific torque value cannot be given for the cable gland. Tighten it until the rubber offers resistance, and thereafter, one more full rotation.

1.4 Complete pump overhaul

A complete overhaul of the pump should be carried out if there has been water or oil in the motor housing or if the pump has been in daily operation for more than a year. At low utilization of the pump the overhaul intervals can be extended. For complete overhaul follow the workshop manual and dismantle the pump completely, replace damaged and worn parts. Use only Sulzer spare parts.

Spare part lists are available in the download section of the Sulzer website at www.sulzer.com.

1.5 Cleaning of pump before service

Before overhaul or maintenance is started the pump should be cleaned. High pressure water is recommended. If the pump has been operating in tough applications additional solvents can be used. To clean the pump from lime deposits it is recommended to lower the pump in a bath containing formic acid (15%) and 85% water for some hours. If needed leave the pump longer. Clean the pump again with high pressure water. Another example is to use Beto 2000 which is a solvent for concrete deposits.

1.6 Recycling in case of scrapping the pumps

Recycling of individual pump parts is beneficial to the environment. The pump can be fully dismantled for recycling. Aluminium, stainless steel, ductile iron and high chrome cast iron can be recycled when a pump is scrapped. Wear parts which consists of rubber/polyurethane/aluminium/steel and cables/stators with copper must be treated before recycling is possible. Environmental white oil should be left to designated areas.

2 Electrical check

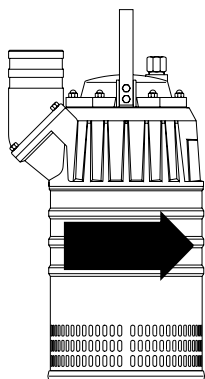

Figure 1: Direction of rotation

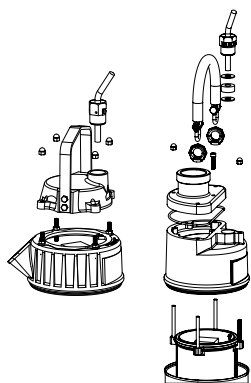

Figure 2: Removing cover and cable gland

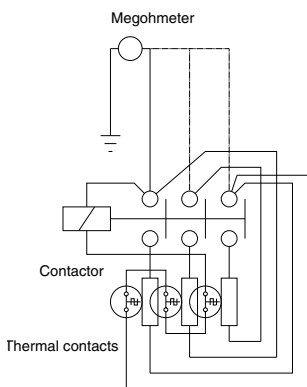

Figure 3: Megging of windings

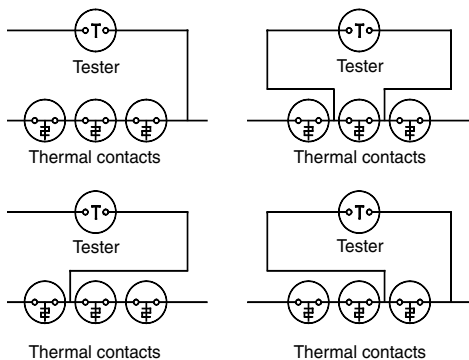

Figure 4: Testing of the thermal contacts

2.1 Pump start and cable check



DANGER! Always check that the pump is disconnected from the electric power supply before opening any part of the pump.

- Check if the pump starts by connecting it to the power supply.
- Check the direction of rotation, it should make a jerk in the direction of the arrow on the pump (anti-clockwise). To change direction of rotation shift two phases. (Figure 1)
- Check the cable for damage and that there is no water or corrosion in the connecting plug.
- Test the insulation between cable end / plug and earth.

2.2 Dismantling cover

Unscrew the cap nuts/screws for the cover. Lift off the cover and disconnect the power cables from the contactor/terminal block. If the water has penetrated through the cable gland, the cable seal should be replaced. Remove strain relief clamp prior to unscrewing cable gland body. Pull out cable, cable seal and washers. (Figure 2)

2.3 Insulation test

Disconnect all stator leads from the contactor/terminal block. Check that the contact points are not burned. Measure insulation resistance between the different phase windings, between windings and earth and between windings and thermal contacts circuit.

The insulation resistance should be measured with 500V megohmmeter (megger) and the reading should be at least 1 MΩ. (Figure 3) If the insulation resistance is lower, the stator unit should be dried in an oven. If the stator insulation reading after drying is still low, the stator unit should be replaced.

The insulation between the separate turns in the winding should also be checked. This can be done by measuring the resistance of the phase windings, which should give the same reading for all three windings for 3-phase motors. For resistance values and wiring diagrams check section 10.

2.4 Thermal contacts

The circuit with the three built-in thermal contacts should be checked for continuity, using an ohmmeter or buzzer. (Figure 4)

If the circuit is open the defective contact should be identified by checking each individual thermal contact. The faulty thermal contact can be bypassed in accordance with the wiring diagram.

3 J, JC Diffuser check / JS Volute removal

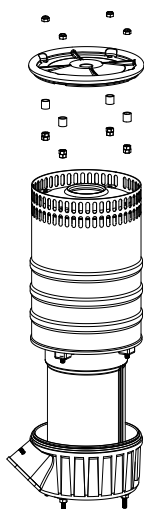

Figure 5: Removing base plate, diffuser and cooling jacket (J, JC)



Figure 6: Removing base plate, strainer and lower diffuser (J 84SD)



Figure 7a: Removing base plate, rubber sleeves and strainer

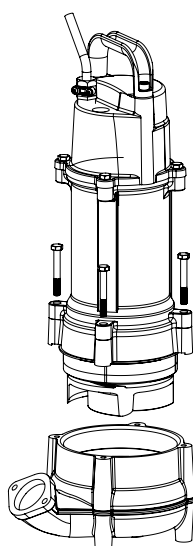

Figure 7b: Removing volute

3.1 Dismantling handle and discharge connection

Take off the handle and the discharge connection.

3.2 Dismantling base plate, diffuser and cooling jacket

J/JC 12-84:

Turn the pump upside down.

Loosen the bottom nuts and remove the base plate and the rubber sleeves.

Unscrew the nuts for the diffuser. Press out the cooling jacket and diffuser with a crow bar applied between the diffuser and the impeller nut. It can be easier to pull out the diffuser and cooling jacket together. (Figure 5)

Check the condition of the diffuser and that the rubber is intact (minimum 2mm) and has a smooth surface.

3.3 Dismantling base plate, strainer and lower diffuser

J 84 SD:

Turn the pump upside down.

Loosen the bottom nuts and remove the base plate and the rubber sleeves.

Loosen the dual nuts and washers that hold the lower diffuser but make sure to leave three nuts to keep the diffuser in place (loosen them a few turns only). Then loosen the strainer by adding leverage from the diffuser by inserting two screwdrivers in the strainer and press against the diffuser. Remove the remaining three nuts and then the lower diffuser by pulling it gently straight out. (Figure 6)

3.4 Dismantling JS base plate, strainer and volute

JS:

Turn the pump upside down.

Loosen the bottom screws and remove the base plate, rubber sleeves and strainer. (Figure 7a)

Put the pump in upright position. Loosen the screws that hold the volute and remove it. (Figure 7b)

4 Oil / Motor check

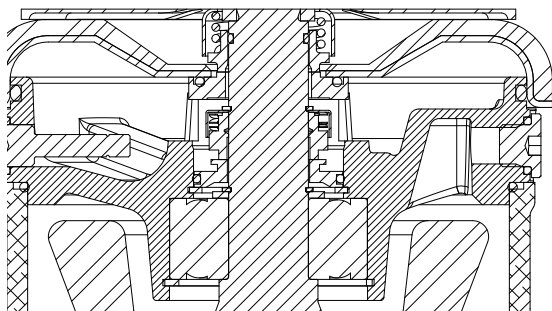

Figure 8: Removing oil plug and motor housing plug

5 Change of impellers

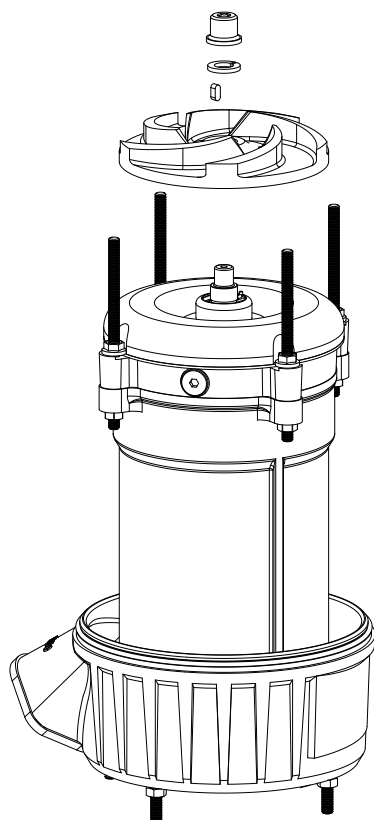

Figure 9: Removing Impeller

4.1 Oil check

J/JC/JS 12-84 Unscrew the oil plug and drain off the oil in a clean can and inspect it. Oil screw is marked "Oil". Attached to the screw is an oil stick for checking the level and cleanliness of the oil.

J 84 SD Unscrew the oil plugs (2pcs) and drain off the oil in a clean can and inspect it. The oil plugs are placed between arrows on the oil casing.

If the oil is milky there is water mixed with the oil.

When refilling with new oil check section 9 for quantity. Always use new o-rings when assembling plugs.

4.2 Motor check

Opposite to the oil plug is a motor plug, giving access to the motor housing. Unscrew and check to make sure no oil or water has leaked into the motor housing.

5.1 Change of impeller

J/JC/JS 12-84:

Dismantling



CAUTION! Impellers may have sharp edges. Take care not to cut yourself on them.

Remove the rubber covers from the stud bolts. Hold the impeller with a large screwdriver or similar, between the vanes and unscrew the impeller nut with an 8mm Allen key (5 mm Allen key on J 12-15). Pry the impeller loose with two screwdrivers under the impeller hub.

J/JS 12-15 Remove the holding ring from the shaft.

J/JC/JS 24-84 Remove the key from shaft. If the impeller is stuck, hit it carefully in circles with a hammer.

Assembly

J 12-15 Mount the holding ring on the shaft. Place the impeller on the shaft and fasten it while checking that the impeller runs straight. Check that the impeller runs free of wear plate with a clearance of 1-2 mm (0.04" - 0.08").

J/JC 24-84 Mount the new impeller on the shaft, securing it with key, spring washer and nut. Check that the impeller runs free of wear plate with a clearance of 0.5 - 1 mm (0.02 - 0.04"). Adjust the clearance with shims between impeller and the shaft if necessary.

5.2 Change of lower impeller, guide vane plate, upper diffuser and upper impeller

J 84 SD:

Dismantling

Hold the impeller with a large screwdriver or similar, between the vanes and unscrew the impeller nut with an 8mm Allen key. Turn the impeller so the three marks on the impeller side meet the channels of the guide vane plate. Pry the lower impeller loose with screwdrivers on the marks of the impeller sides. Remove the key from the shaft. If the impeller is stuck, hit it carefully in circles with a hammer and use a creeping lubricant if needed. Remove the tube distance between the impellers and pull out the guide vane plate. Note the number of 0.5 shims on top of the tube distance before removing them, also check for shims under the tube distance and or top of the lower impeller. Pull out the upper diffuser. Turn the impeller so the three marks on the impeller side meet the channels of the wear plate. Pry the upper impeller loose with screwdrivers on the marks of the impeller sides. Remove the key from the shaft. If the impeller is stuck hit it carefully in circles with a hammer. Check if there are shims on top of the upper impeller, if so remove them too.

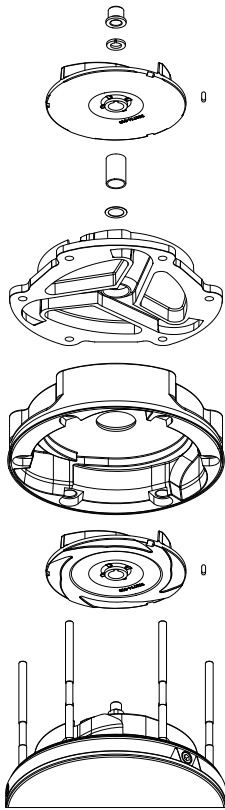

Figure 10: Removing lower impeller, guide vane plate, upper diffuser and upper impeller (J 84 SD)

Assembly

Put the shims on the shaft, then the upper key in place on the shaft and mount the new upper impeller. Check that the impeller runs free of wear plate. Adjust the clearance with shims between impeller and shaft if necessary. Put on the upper diffuser and then the guide vane plate on the stud bolts and push them in place. Check that the distances are in place in the diffuser. Place the shims and then the tube distance between the impellers on the shaft and mount the new lower impeller on the shaft securing it with the key, spring washer and nut. Check that the impeller runs free of guide vane plate. Adjust the clearance with shims between the tube distance and upper impeller if necessary.

Complete Assembly

Mount the lower diffuser on the stud bolts and screw two screws onto each stud bolt. Check that the distances are in place in the diffuser. Grease and mount o-ring on the oil casing. Put the strainer in place and then the rubber sleeves and the base plate. Tighten it up with the bottom nuts.

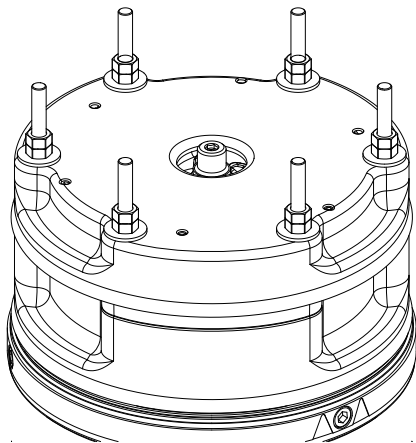

Figure 11: Assembly lower diffuser (J 84 SD)

6 Change of primary seal and wear plate

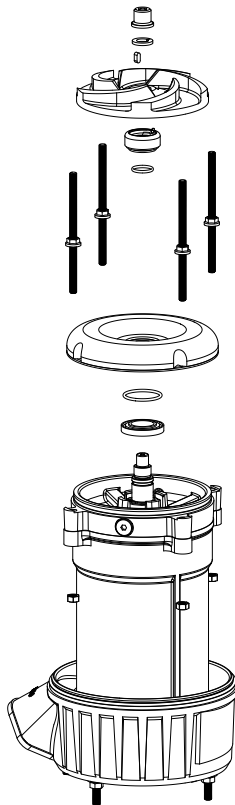

Figure 12: Removing primary seal and wear plate

Dismantling

J/JS 12-15 Remove washer, circlip and rotating parts of primary seal from the shaft. Remove the stud bolts. Withdraw the wear plate by using a screwdriver and remove the stationary ring of the primary seal.

J/JC/JS 24-84 Pull out the primary seal with steel cup, spring and rotating ring. Remove the o-ring from the shaft. Remove the nuts on the stud bolts which hold the wear plate, oil casing and stator housing together. Remove the stud bolts. Withdraw the wear plate by using a screwdriver and remove the stationary ring of the primary seal.

Always use new mechanical seals for assembly.

Assembly

Mount stationary ring of primary seal with o-ring in its seat in the oil casing.

Before the outer o-ring is mounted on the oil casing, check that the wear plate is compressing the o-ring in the stationary seal enough to give efficient sealing.

Grease and mount o-ring on the oil casing, and assemble wear plate with stud bolts and nuts. Mount the rubber covers on the stud bolts and over the knobs on stator housing and oil casing. Grease and mount a new primary seal o-ring on the shaft. Oil the sealing surfaces of the mechanical seal and push the rotating ring onto the shaft. Assemble the spring and the steel cup. (Figure 12) For assembly of pump proceed in reverse order from section 6 to 2.

7 Complete pump overhaul / dismantling

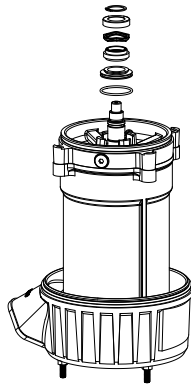

Figure 13: Removing secondary seal

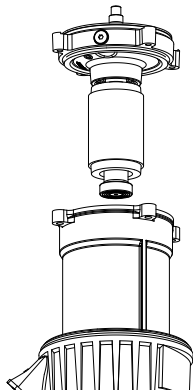

Figure 14: Removing rotor unit

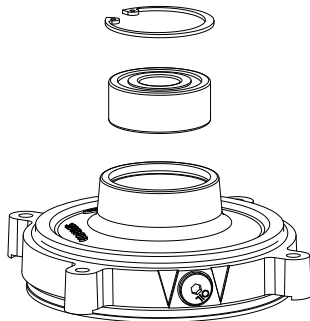

Figure 15: Removing lower bearing

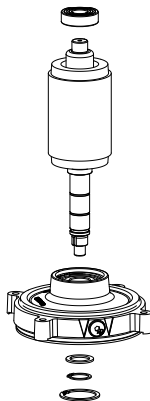

Figure 16: Removing rotor and upper bearing

7.1 Secondary seal

Remove circlip and rotating parts of secondary seal from the shaft. Remove the stationary ring with two screwdrivers. (Figure 13)

7.2 Rotor unit with oil casing

Turn the oil casing about 15 degrees and pry it loose from the stator housing with a screwdriver. Lift out the rotor unit. (Figure 14)

Remove the external circlip on the shaft (J/JC/JS 24-84) (holding the bearing) with a pair of circlip pliers for diameter 25 mm. (Figure 15)

The rotor shaft has to be pressed out of the ball bearing. Place the rotor into a tube of the same length as the rotor shaft and with an inner diameter slightly larger than the outer diameter of the bearing seat. Press against the end of the shaft until the rotor comes loose. If high pressure is needed, screw the impeller nut fully on the shaft end in order to protect it.

7.3 Ball bearings

Remove the circlip on the oil casing holding the ball bearing and press out the bearing. The bearing seat can be heated quickly with LP-gas to facilitate the removal. Pull out the upper ball bearing with a puller. (Figure 16)

7.4 Stator unit with contactor

Unscrew the studs for the main cover and lift off the main cover from the stator unit.

8 Exchange of the stator

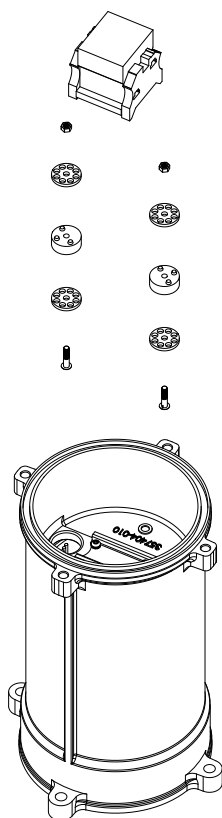

Figure 17: Removing wire seal

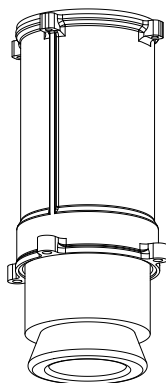

Figure 18: Removing stator from housing

8.1 Removal of stator

Remove the contactor. Loosen nuts for the motor housing cable seal and pull out the seals. (Figure 17)

Arrange the motor cables so as to avoid jamming when the stator is falling out of the housing. Remove the o-ring in the upper bearing seat.

Put the motor housing on distance pieces.

Heat the motor housing with two LP gas flames (Large propane burner) at the stator laminations and downwards until the temperature of about 250°C (482°F) is reached or till the stator starts to fall out. (Figure 18)

Clean the housing and check it for damages, particularly on the sealing surfaces and in ball bearing seat. If damages cannot be corrected, the housing must be rejected.

8.2 Mounting of stator

Block up the new stator and make sure that the housing can be fully pushed down onto the stator. Protect the stator insulation from damages and put down the thermal wires (free from insulation resin and smooth) into the stator to avoid contact with the hot housing during assembly.

Heat the housing with two LP-gas flames to about 198° to 250°C (388° to 482°F). With two 25 mm nozzles this will take about one minute. Take the hot housing with heat-resistant gloves and push it down till it stops over the housing.

Note!

Locate the holes for the thermal cables in the housing about 10 mm from the exit of the cable groups on the winding head.

When the housing has been mounted it may be cooled by compressed air.

When the housing has cooled down the terminal cables can be pulled up through the holes in the housing with a hook made of steel wire. Mount the cable bushings (6-hole seals) on the two groups of 3 cables.

8.3 Thermal contacts

The thermal switches are connected in series and the joints should be well insulated.

9 Complete pump overhaul assembly

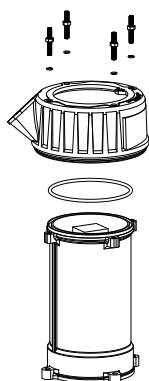

Figure 19: Assembling stator unit, contactor, main cover

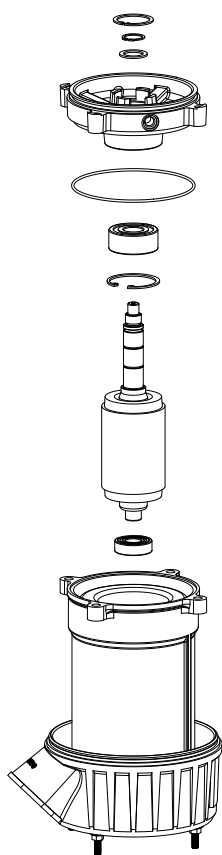

Figure 20: Mounting rotor unit

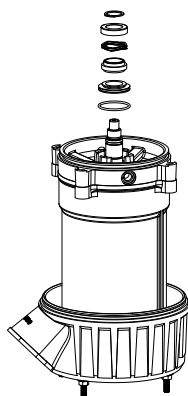

Figure 21: Mounting secondary seal

9.1 General

Prior to assembly, clean all parts carefully, especially o-ring grooves and mating surfaces. Grease or oil o-ring to eliminate damage during assembly. Put some grease or oil on the screw threads to simplify disassembly during future overhaul.

9.2 Stator unit, contactor, main cover

Grease and mount the o-ring in the upper bearing seat. Connect all stator leads to the contactor according to the wiring diagram (see section 10) and mount the contactor at the bottom of the contactor chamber.

Grease and mount the o-ring between stator unit and main cover. Mount the main cover on the housing and tighten it against the stator housing with the nuts. Check the o-ring and stator leads so that they have not been jammed. (Figure 19)

9.3 Ball bearings and rotor unit

Turn the stator unit with main cover mounted upside down.

Clean the oil casing and all sealing surfaces thoroughly. Remove burrs and scratches. All ball bearings are sealed and pre-filled with grease for lifetime performance.

Mount the circlip below the bearing seat on the oil casing (stop for secondary seal).

Heat the bearing seat with LP-gas to about 150°C (302°F) and mount the bearing in the seat. Mount the circlip on top of the bearing.

Place the oil casing on the mandrel with hole for the rotor shaft and resting against the inner ring of the ball bearing.

Place upper bearing on the shaft and press both bearings into position against the shaft shoulders.

J/JC/JS 24-84 Mount washer and circlip on the shaft below the lower bearing.

Turn the rotor by hand and check that it turns freely without seizing.

Grease and mount o-ring on the casing. Slip the rotor unit into the stator unit and check that the o-ring is not jammed. (Figure 20)

9.4 Secondary seal

J/JS 12-15 Clean and grease the seal seat in the oil casing and mount the stationary ring with o-ring. The small o-ring should be replaced.

J/JC/JS 24-84 Clean and grease the seal seat in the oil casing and mount the stationary ring with o-ring. Push it down to the bottom of the seat with the seal tool 96990370.

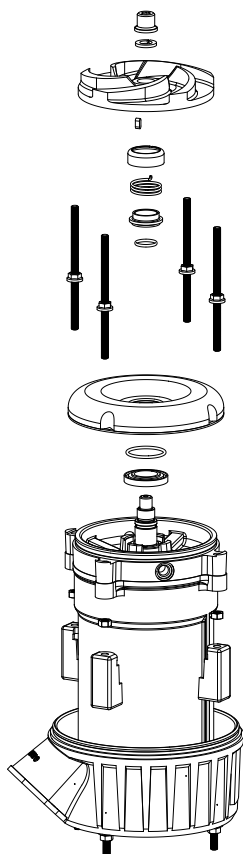

Figure 22: Mounting primary seal, wear plate and impeller

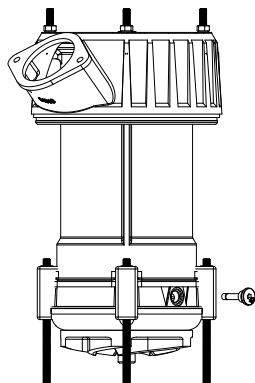

Figure 23: Filling oil

Push the rotating part of the secondary seal onto the shaft with the seal tool 00831803. Mount the circlip and push the tool down till the circlip fits into the groove. On J/JC/JS 24-44 the clearance between circlip and stationary ring should be approx. 1 mm. (Figure 21)

9.5 Primary seal and wear plate

Mount stationary ring of primary seal with o-ring in its seat in the oil casing.

Before the outer o-ring is mounted on the oil casing, check that the wear plate is compressing the o-ring in the stationary seal enough to give efficient sealing.

Grease and mount o-ring on the oil casing, and assemble wear plate with stud bolts and nuts. Mount the rubber covers on the stud bolts and over the knobs on stator housing and oil casing.

J/JS 12-15 Oil the sealing surfaces of the mechanical seal and push the rotating part of the seal onto the shaft. Mount the circlip and push the tool down till the circlip fits into the groove.

J/JC/JS 24-84 Grease and mount a new primary seal o-ring on the shaft. Oil the sealing surfaces of the mechanical seal and push the rotating ring onto the shaft. Assemble the spring and the steel cup. (Figure 22)

9.6 Impeller



CAUTION! Use gloves when mounting impeller, impellers may have sharp ends..

J/JS 12-15 Always use a new impeller washer for assembly. Mount the impeller washer and impeller on the shaft and fasten the impeller screw. Check that the impeller runs free of wear plate with a clearance of 1 - 2 mm (0.04 - 0.08").

J/JC/JS 24-84 Mount the impeller on the shaft, securing it with key, spring washer and nut. Check that the impeller runs free of wear plate with a clearance of 0.5 - 1 mm (0.02 - 0.04"). Adjust the clearance with shims between impeller and the shaft if necessary.

9.7 Refilling of oil

Fill new oil in the oil chamber (Figure 23)

Oil type:

Paraffin oil (white oil) with viscosity 10 - 15 cSt, e.g. BP Enerpar M 002 or equivalent

Correct quantities:

J/JS 12 - 15	0.35 litres	0.09 US gallon
J/JC/JS 24 - 44	0.5 litres	0.13 US gallon
J/JC/JS 54 - 84	0.9 litres	0.24 US gallon

Oil level can also be checked with the oil stick on J/JC/JS 24-84 (except J 84 SD). Tighten the oil plug with a new o-ring.

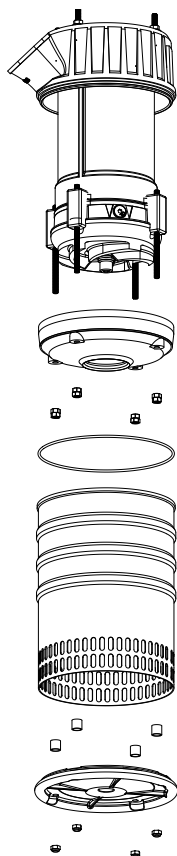

Figure 24: Mounting diffuser, cooling jacket and base plate

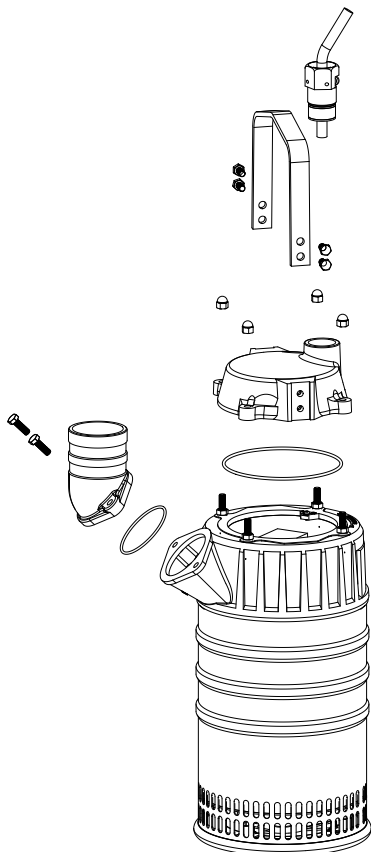

Figure 25: Assembly handle, cable gland, cover and discharge connection

9.8 Diffuser and cooling jacket

Mount the coil springs on the stud bolts (J/JC/JS 54-84). Mount the diffuser on the stud bolts and screw one nut onto each stud bolt.

Grease and mount the o-ring on the main cover. Also grease the outer diameter of the diffuser.

Push the outer casing over the diffuser towards the main cover and check that the o-ring is not being jammed.

Tighten the nuts for the diffuser alternately until the impeller runs free from the diffuser with a clearance of 0.1 - 0.3 mm (0.004 - 0.012"). Loosen the nuts about 1/3 of a turn and lock with jam nuts. For single-phase pumps and polyurethane the clearance should be 0.3 mm or more. Mount the rubber sleeves. (Figure 24)

9.9 Base plate

Mount the base plate and tighten it firmly with lock nuts.

Turn the pump around to an upright position.

9.10 Handle, cable gland, cover and discharge connection

Measure inner diameter of cable seal to see that it corresponds to the cable diameter. Place cable seals and washers (one on each side of the bushing) on the cable.

Pull cable through the cover, far enough to let the cable seal seat on a non-deformed portion of cable. Tighten the cable gland and strain relief clamp.

Connect the phase leads to the contactor according to wiring diagram and screw the yellow / green earth lead in the main cover. Grease and mount the o-ring on the cover. Mount the cover on the main cover and arrange the leads so that they may not be jammed or block the functioning of the contactor. Tighten the cover with the cap nuts.

Mount the handle and the discharge connection back on the pump and tighten the screws. Mount the plug if supplied at the other end of the cable. (Figure 25)

9.11 J 84 HD - 50 Hz

Assembly and adjusting the diffuser and impellers (two impellers).

Please note that the second impeller is adjusted by washer and locked by a distance sleeve, having the same length as the hub of the first impeller.

The guide vane is screwed together with the diffuser by three screws + Loctite in the treads. Distance sleeves (six pcs) are placed between the diffuser and the guide vane. Partly mounted details are put down on the stud bolts. Then put six pcs of washer and six pcs of nuts on the guide vane.

Adjust the diffuser against the impeller. After this the nuts are slacked loosen (opened) a quarter of one turn. It is important that the impeller is close to the diffuser in order for the pump to give the promised high head.

That the diffuser is correct installed (parallel) can be checked by measuring the distance from the guide vane up to the motor. The distance between the upper side of the impeller and the guide vane is adjusted by shims to about 1 to 1,5 mm. Please note that the shaft key should be fitted after the shims.

The washers (six pcs) are placed on the stud bolts and thereafter the diffuser. The distance between the impeller and the diffuser are adjusted by one or several adjusting shims. It has to be the same amount on each stud bolt. The distance should be about 0,1 to 0,2 mm. Two nuts on each other are then locking it all.

Mount the rubber sleeves on the nuts, the outer casing and the bottom plate.

It is advisable, to save time, that the pump is always started for a few seconds to check that the impellers are rotating while still in the workshop. If the nuts are screwed on too tight the impellers are too close to the diffusers.

9.12 Testing

Connect motor cable to power supply and start the pump. Check the direction of rotation. Seen from above the pump, it should make a counter-clockwise jerk.

If possible, operate the pump in water and measure the head against closed valve.

10 Electrical information and wiring diagrams

10.1 Three phase Direct Start D.O.L. (6-leads stator) with contactor

The stators are wound for different voltages and can be Delta- or Star-connected. For example stator 400/690 V 50Hz is Delta-connected for 400V duty. (Figure 26, 27, 28, 29)

The contactor is activated by the same voltage as the supply voltage. Therefore, when changing from one voltage to another the contactor must also be changed.

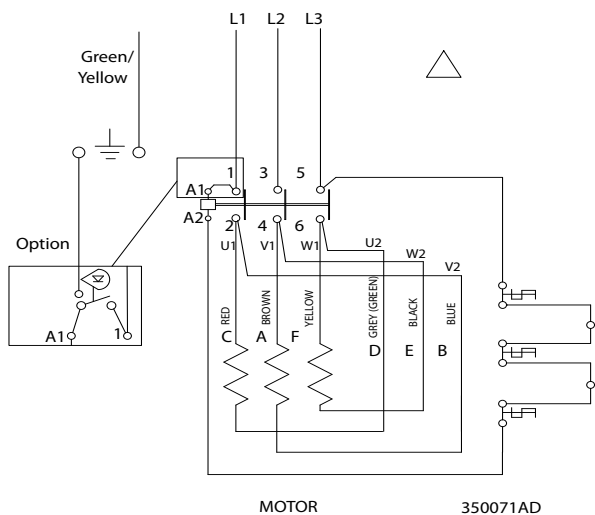

Figure 26: Delta connected windings D.O.L.

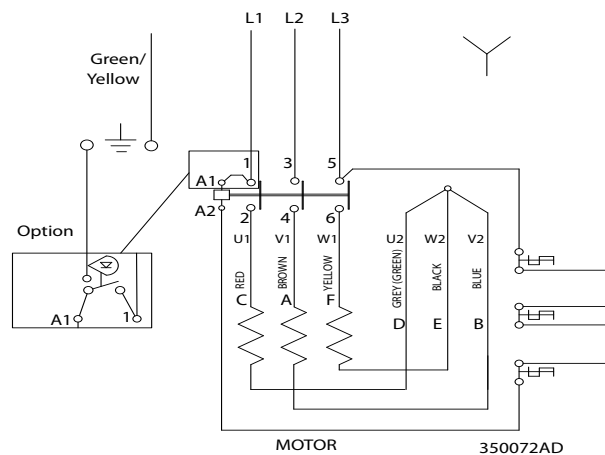

Figure 27: Star connected windings D.O.L.

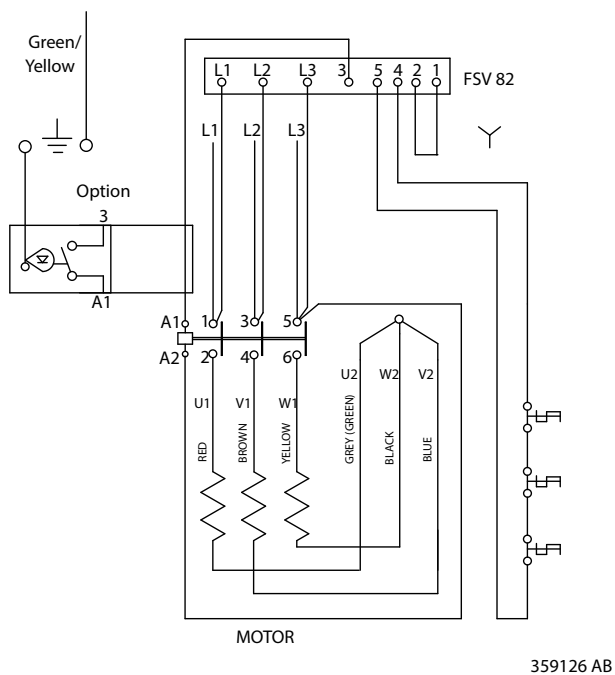

Figure 28: Delta connected winding D.O.L. with FSV.

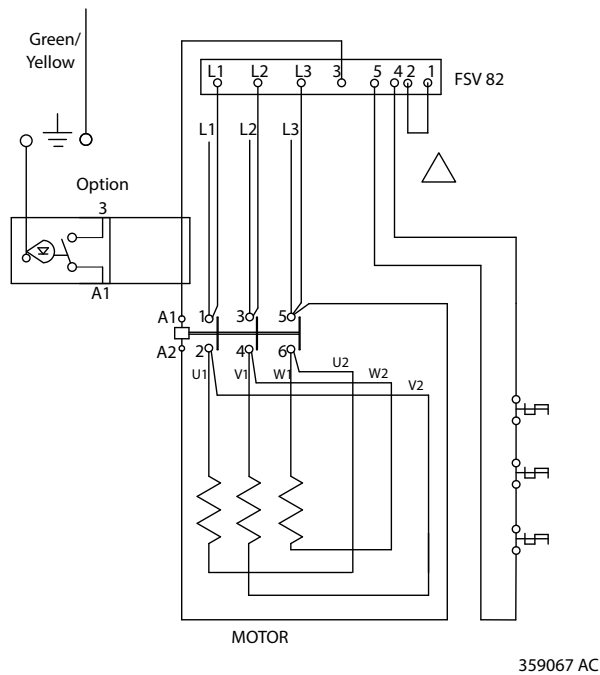
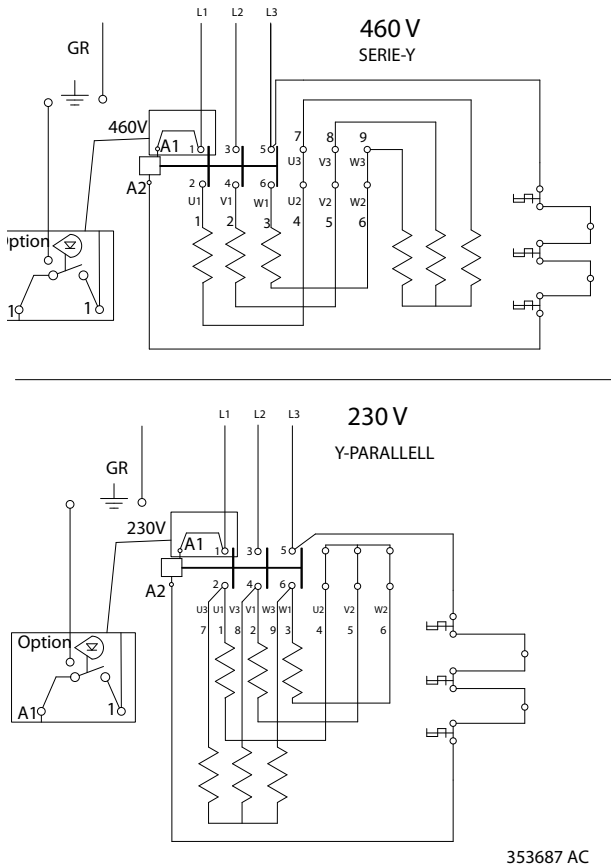

Figure 29: Star connected winding D.O.L. with FSV.

10.2 Three phase Direct Start D.O.L. 230/460V 60Hz (9-leads stator)

The stators are wound for dual voltage and can be changed from one voltage to the other by changing the parallel connection (e.g. 230V) to serial connection (e.g. 460V). (Figure 30, 31)

The contactor is activated by the same voltage as the supply voltage. Therefore, when changing from one voltage to another the contactor must also be changed.



353687 AC

Figure 30: 230/460V 60Hz 9-lead D.O.L. with contactor.

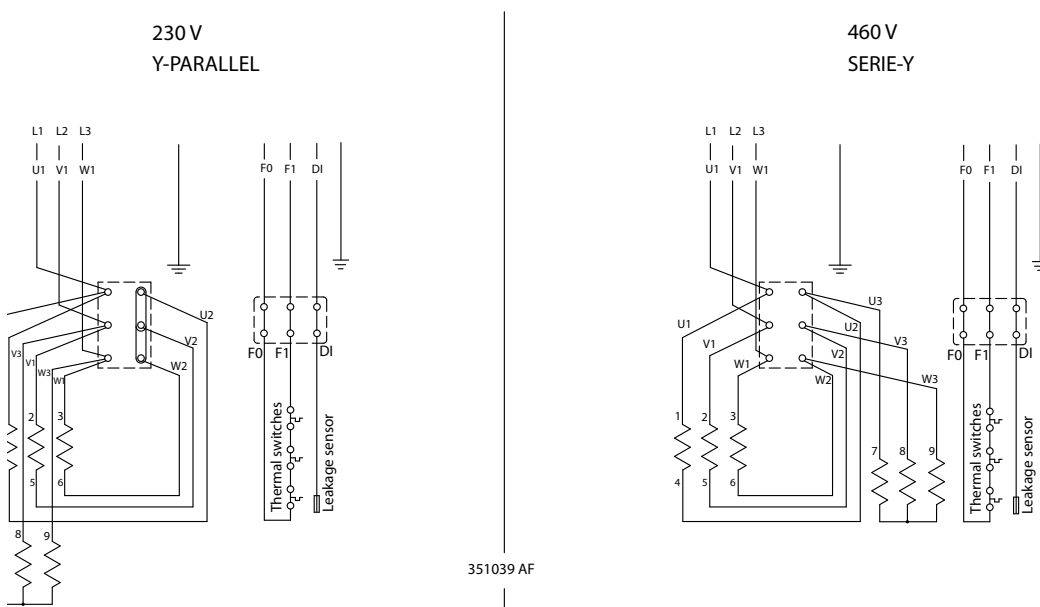

351039 AF

Figure 31: 230/460V 60Hz 9-lead D.O.L. with terminal block.

10.3 Three phase Direkt Start D.O.L. 1000V 50Hz with terminal block

The stators are wound for 1000V 50Hz and connected Star. (Figure 27). When optimal ground check diode is used see figure 32 and 33.

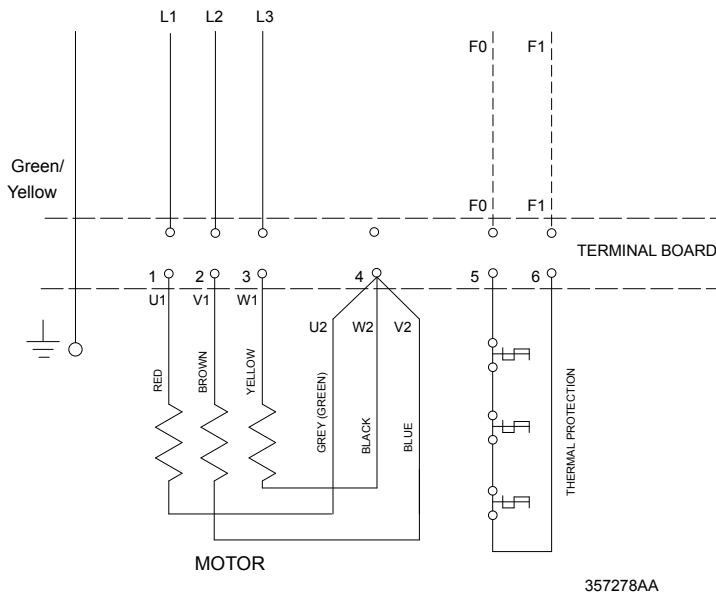

Figure 32: Standard connecting for Direct Start D.O.L 1000V 50 Hz.

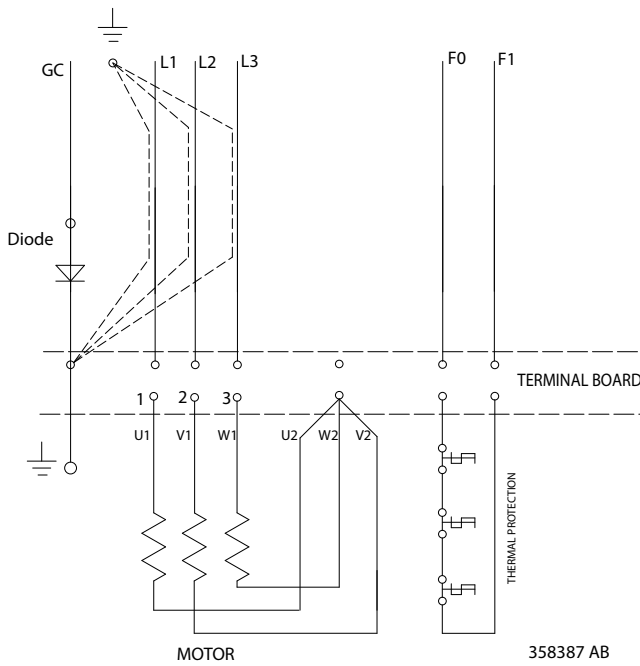

Figure 33: Optional: Connecting for Direct Start D.O.L 1000V 50Hz with ground check diode.

10.4 Three phase Star Delta starting with terminal block

The star delta starting is obtained by using a separate starter. The power wires and control wires are in one cable connected as shown in figure 34, 35 and 36.

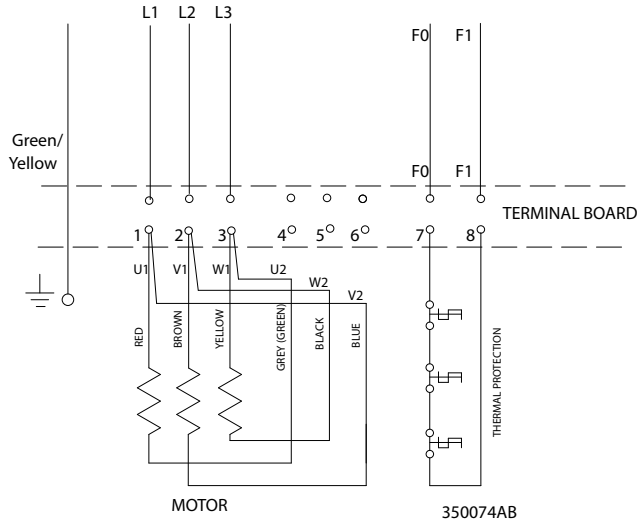

Figure 34: Delta connected windings D.O.L.

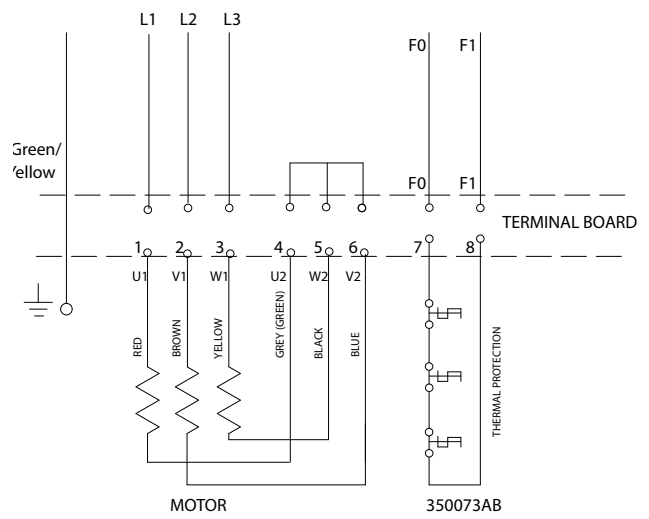

Figure 35: Star connected windings D.O.L.

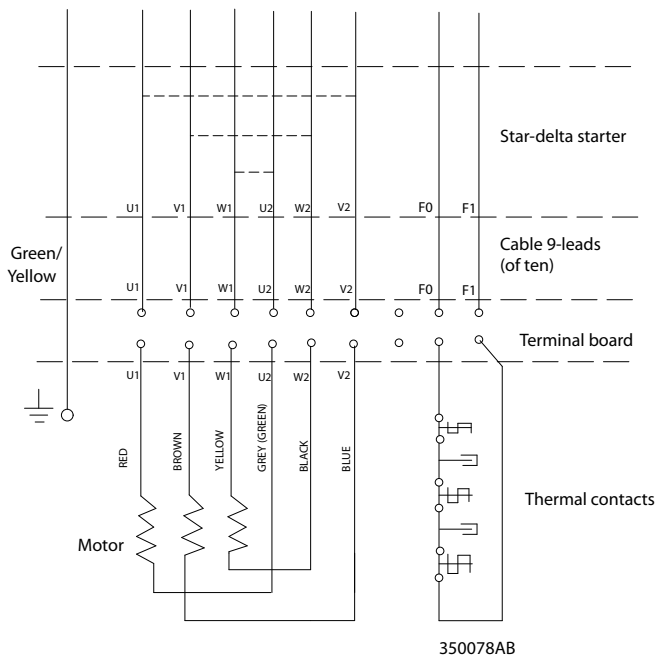

Figure 36: Connecting for Star / Delta Start.

10.5 Single phase

The stators are wound for different voltage and all Sulzer single phase pumps are equipped with built in capacitors for start. Pumps can be equipped with float switch direct connected at the pump. Figure 37, 38 and 39.

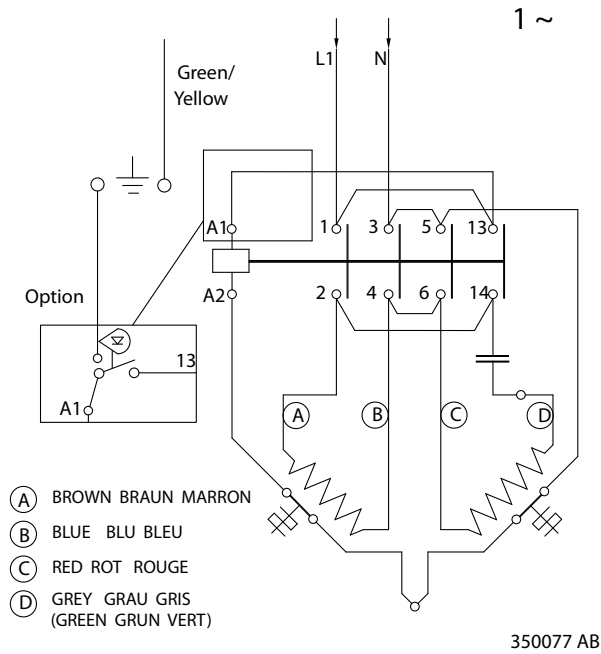

Figure 37: Pump with built in contactor and capacitor. Optional float switch.

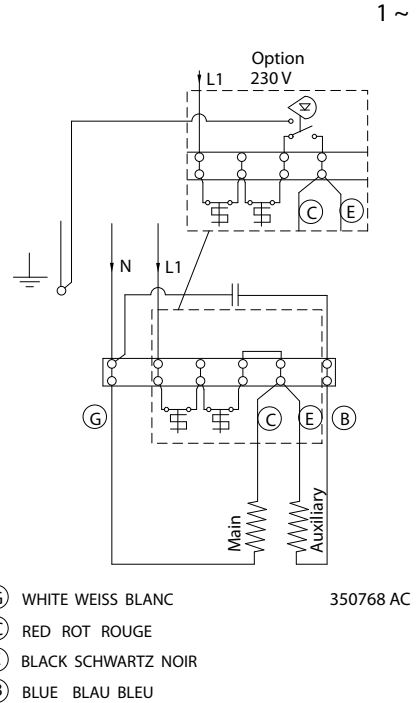

Figure 38 Pump with terminal block built in capacitor. Thermal protection by series connected temperature switches. Optional float switch.

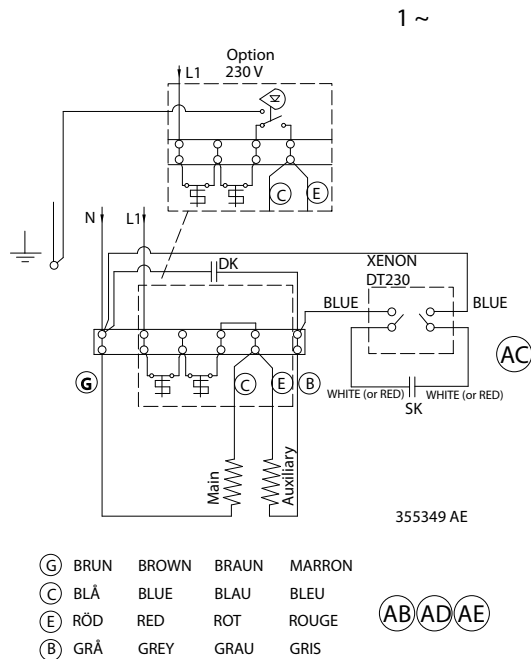

Figure 39: Pump with built in start relay operating a separate capacitor. (2 capacitors) Thermal protection by series connected temperature limiting switches. Optional float.

10.6 Fuses

Fuses are to be installed in the power circuits as a short circuit protection. Fuses with a time lag are recommended. The table shows the nominal current and starting current factor. Multiply factor with nominal current to get the pumps starting current.

Three-phase 50Hz						Three-phase 60Hz				
Pump	230V	400V	500V	1000V	Starting current factor	Pump	230V	460V	575V	Starting current factor
J 12	4A	2.3A	1.9A	-		J 12	4.4A	2.2A	1.8A	
J 15	5A	2.9A	2.3A	-		J 15	5.4A	2.7A	2.2A	
J/JC 24	8.4A	4.8A	3.8A	1.9A	7.3	J/JC 24	9.8A	4.9A	3.9A	6.9
J/JC 44	14A	8.1A	6.5A	3.2A	6.4	J/JC 44	15A	7.4A	5.9A	8.2
J/JC 54	21A	12A	9.2A	4.6A	6.2	J/JC 54	22A	11A	8.8A	
J/JC 84	31A	18A	14A	7A	5.8	J/JC 84	34A	17A	14A	
JS 12	3.3A	1.9A	1.5A	-	5.3	JS 12	3.8A	1.9A	1.5A	5.8
JS 15	4.5A	2.6A	2.1A	-	5.4	JS 15	5.2A	2.6A	2.1A	6.2
JS 24	7.3A	4.2A	3.4A	-	8.0	JS 24	8.2A	4.1A	3.3A	8.3
JS 44	12A	6.9A	5.5A	-	7.1	JS 44	13.8A	6.9A	5.5A	8.8
JS 54	19.1A	11A	8.4A	-	6.7	JS 54	22A	11A	8.8A	
JS 84	27.8A	16A	12.2A	-	6.6	JS 84	30A	15A	12A	

Single-phase 50Hz			
Pump	110V	230V	Starting current factor
J 12	10.4A	5.2A	
J 15	-	8.1A	
J/JC 24	-	10.5A	
JS 12	-	5.1A	5.5
JS 24	-	9.8A	

Single-phase 60Hz			
Pump	115V	230V	Starting current factor
J 12	13A	6.5A	
J 15	-	9.5A	
J/JC 24	-	13.4A	
JS 12	-	6.6A	5.3
JS 24	-	12A	

11 Sectional drawing / Tools

J

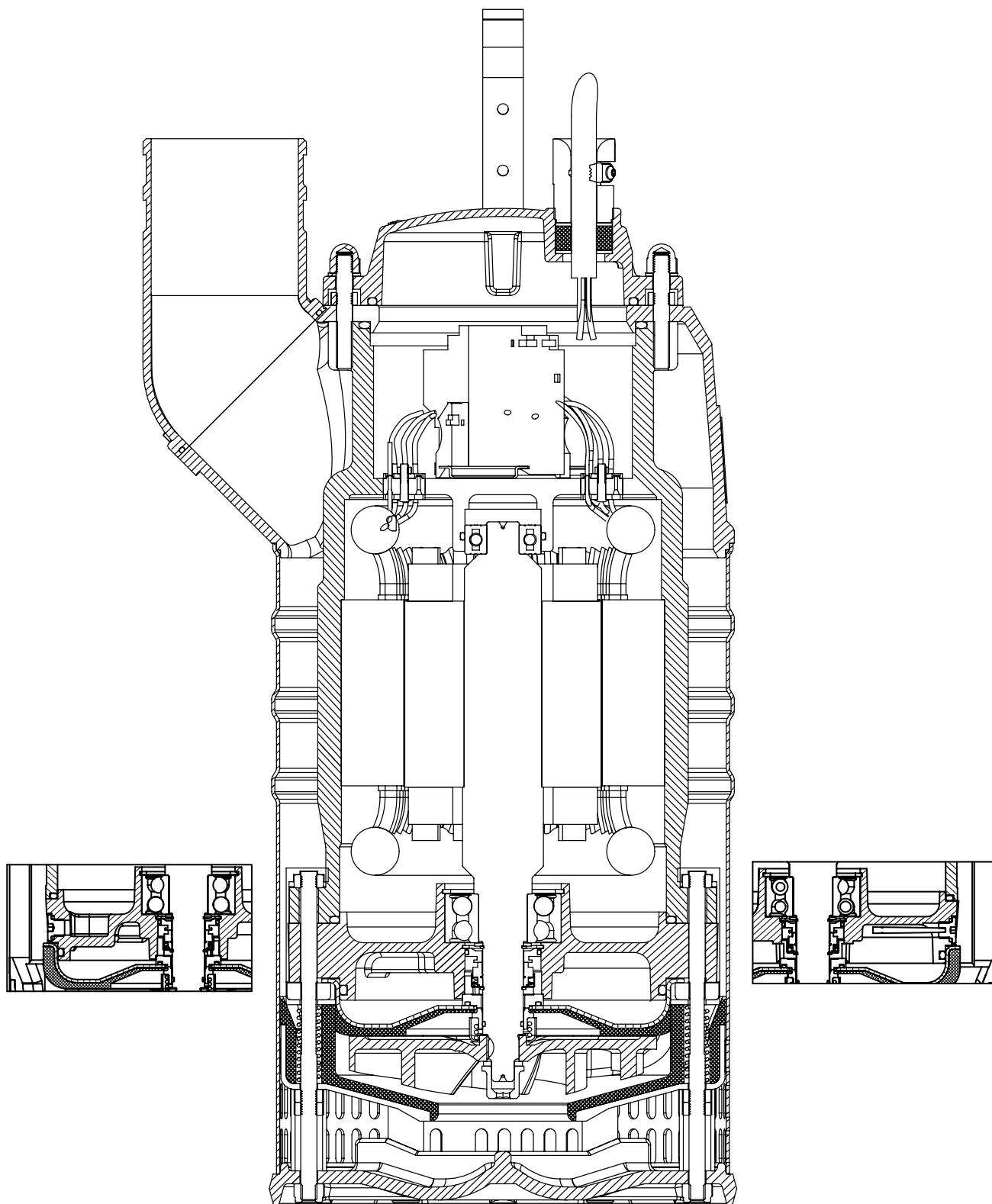

JC

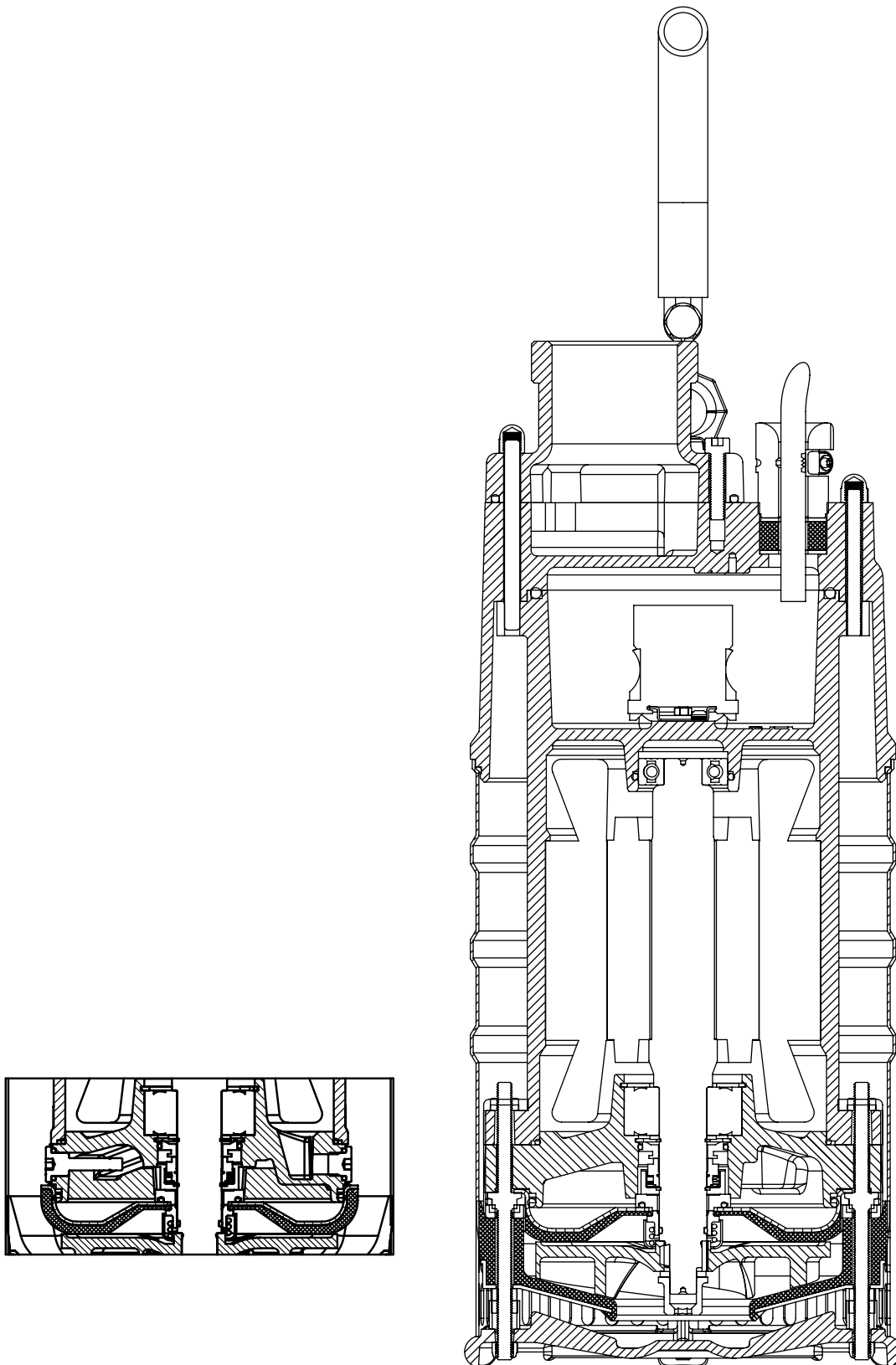

JS

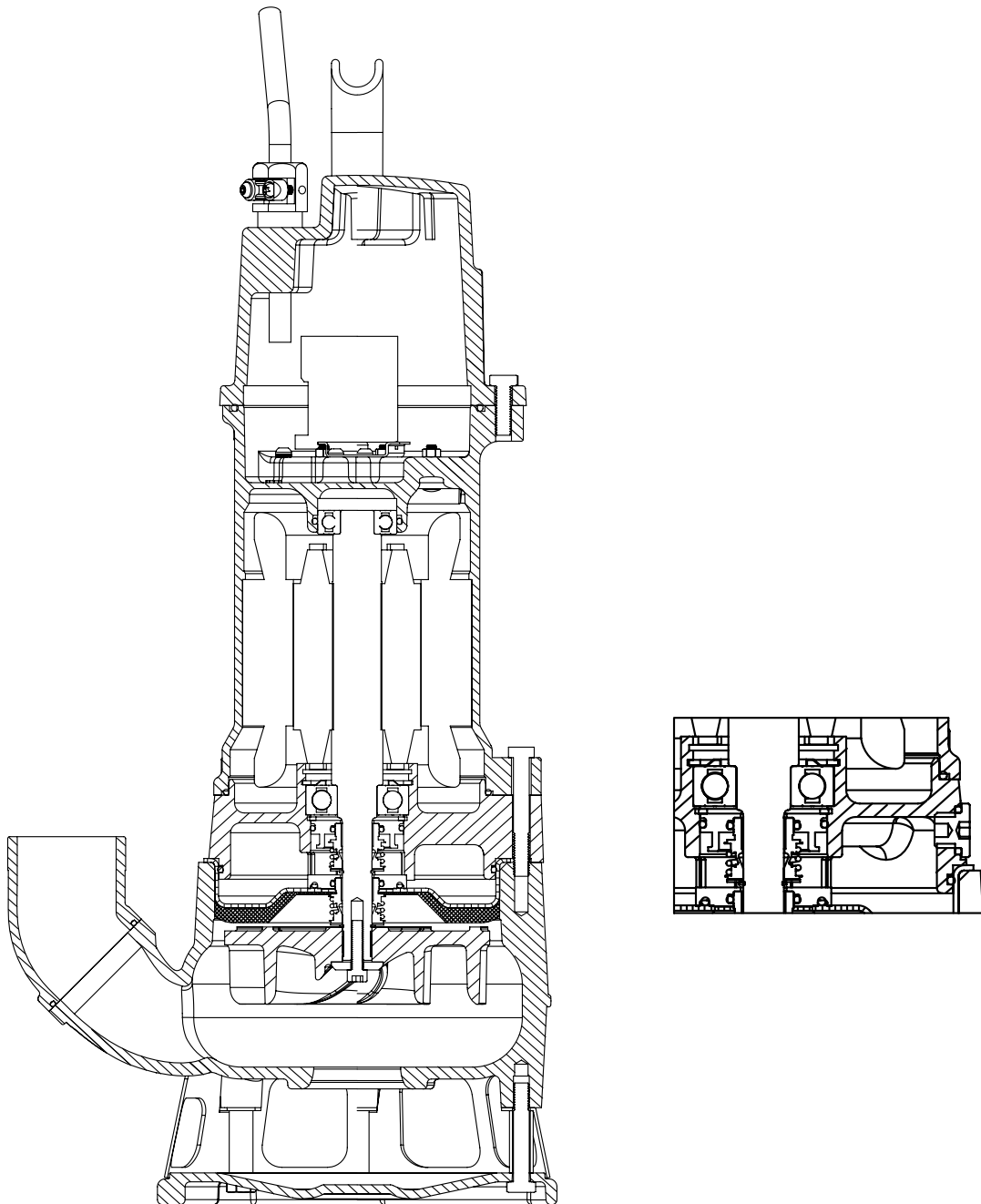

**Assembly tool for stationary part,
secondary seal J/JC/JS 24 - 84
(part No 96990370)**

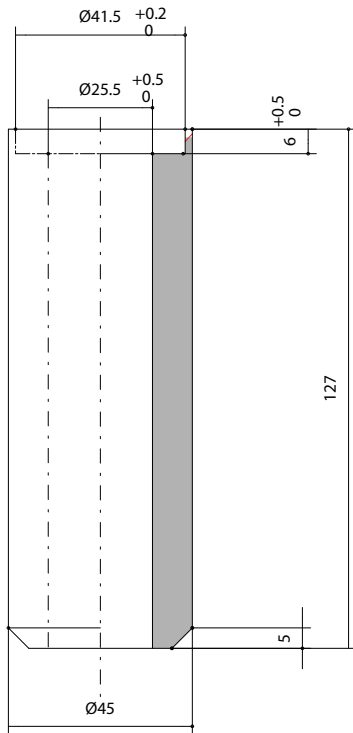

**Assembly tool for rotating part and circlip,
secondary seal J/JC/JS 24 - 84
(part No 00831803)**

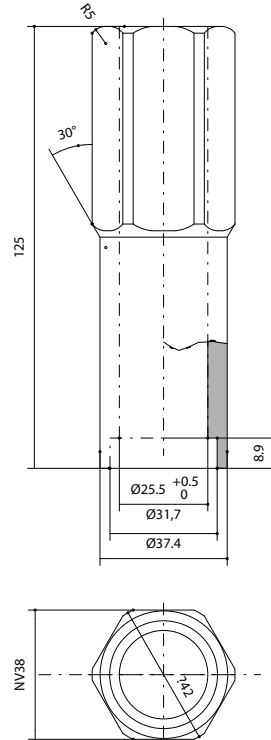

**Special tool for secondary seal J/JS 12-15
(part No 00830342)**

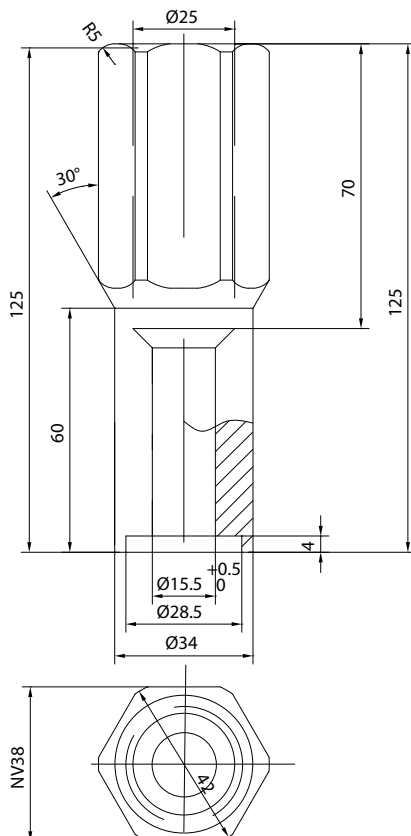

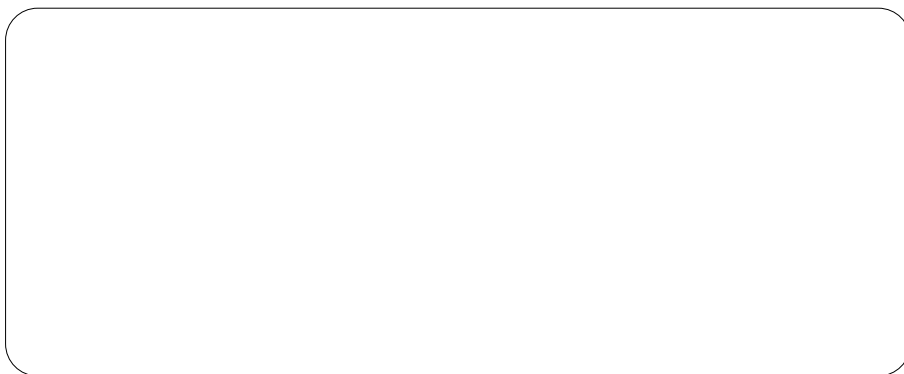

SULZER

Sulzer Pump Solutions Ireland Ltd., Clonard Road, Wexford, Ireland
Tel. +353 53 91 63 200, Fax +353 53 91 42 335, www.sulzer.com